

# Catálogo de señales verticales de circulación

## Tomo II

### Dimensiones de las señales

marzo 2022



MINISTERIO  
DEL INTERIOR

MINISTERIO  
DE TRANSPORTES, MOVILIDAD  
Y AGENDA URBANA



## ÍNDICE

|   |     |
|---|-----|
| INTRODUCCIÓN .....  | 2   |
| DIMENSIONES DE LAS SEÑALES VERTICALES DE CIRCULACIÓN .....    | 4   |
| SEÑALES DE ADVERTENCIA DE PELIGRO .....                       | 5   |
| SEÑALES DE PRIORIDAD .....                                    | 62  |
| SEÑALES DE PROHIBICIÓN DE ENTRADA .....                       | 68  |
| SEÑALES DE RESTRICCIÓN DE PASO .....                          | 89  |
| OTRAS SEÑALES DE PROHIBICIÓN O RESTRICCIÓN .....              | 95  |
| SEÑALES DE OBLIGACIÓN .....                                   | 115 |
| SEÑALES DE FIN DE PROHIBICIÓN, RESTRICCIÓN U OBLIGACIÓN ..... | 147 |
| SEÑALES DE INDICACIONES GENERALES .....                       | 163 |
| SEÑALES DE CARRILES .....                                     | 232 |
| SEÑALES DE SERVICIO .....                                     | 276 |
| SEÑALES DE PRESEÑALIZACIÓN .....                              | 310 |
| SEÑALES DE LOCALIZACIÓN .....                                 | 313 |
| PANELES COMPLEMENTARIOS .....                                 | 325 |
| OTRAS SEÑALES .....   | 349 |
| <br>  |     |
| ANEXO I. DIMENSIONES DEL ALFABETO CCRIGE .....                | 375 |
| INTRODUCCIÓN .....  | 376 |
| DIMENSIONES DE LOS CARACTERES .....                           | 382 |



## INTRODUCCIÓN

Este tomo II del *Catálogo de señales verticales de circulación* recoge las dimensiones de las señales verticales de circulación, habiéndose acotado los elementos que conforman cada una de ellas.

En las fichas incluidas en este catálogo las dimensiones de las señales han sido expresadas en milímetros, y de forma general se refieren a las señales de tamaño intermedio, correspondientes a aquellas a instalar en las carreteras convencionales con arcén y en las carreteras multicarril.

### Carreteras convencionales con arcén y carreteras multicarril

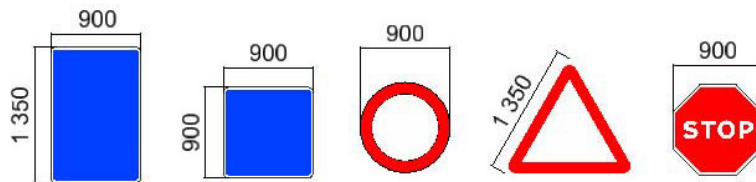

Para obtener las dimensiones de las señales de tamaño grande, correspondientes a aquellas a instalar en autopistas y autovías, y de las de tamaño pequeño, correspondientes a aquellas a instalar en carreteras convencionales sin arcén y en vías urbanas, se aplicarán las dimensiones que aparecen en las siguientes figuras, manteniendo las proporciones entre los distintos elementos de la señal establecidas en este catálogo.

### Autopista y autovía

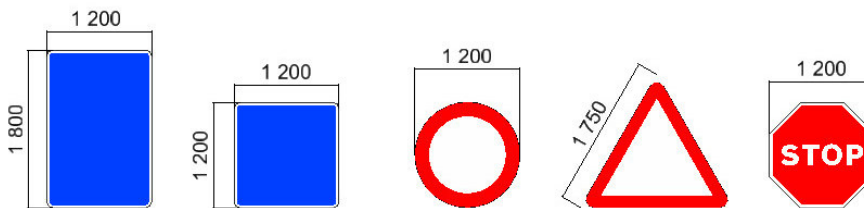

### Carretera convencional sin arcén y vías urbanas

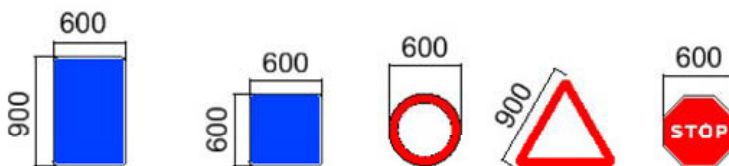

(cotas en mm)



En el caso de las señales rectangulares de autopista o autovía que tienen un ancho mayor de 1200 mm se ha considerado la posibilidad de su fabricación en lamas, por lo que se ha ajustado su altura a 1750 mm.

En las fichas de las señales que por su definición solo se instalen en unos tipos concretos de carreteras figuran las dimensiones correspondientes a estos.

Cualquier excepción a lo establecido en los párrafos anteriores se especifica en la propia ficha de la señal. Se respetará en cualquier caso lo establecido por la norma *8.1-IC señalización vertical* de la Instrucción de Carreteras vigente.

En casos extraordinarios, y siempre de manera justificada, se podrán instalar señales de un tamaño diferente al establecido en este catálogo, dependiendo del espacio disponible y de las características de la circulación.

El alfabeto utilizado en todas las señales que figuran en este catálogo es el CCRIGE, cuyas dimensiones figuran en el anexo I.

En este tomo no se incluyen: las señales de preseñalización (códigos S-200 a S-271, a excepción de la S-250 y la S-260); las de dirección (códigos S-300 a S-380); las de identificación de carreteras (códigos S-400 a S-450); algunas de las de localización (códigos S-500 a S-562 y S-575); las de confirmación (códigos S-600 a S-603) y las de uso específico en poblado (códigos S-700 a S-770). La razón es que las dimensiones de estas señales se definen en función de su contenido, dado que tanto las inscripciones contenidas en las señales como el tamaño del texto utilizado varían dependiendo de la información a suministrar. Tanto el tamaño del texto como la separación entre las distintas líneas y los márgenes hasta el borde del cartel están definidos en la norma *8.1-IC señalización vertical*.

Por lo que respecta a las características y especificaciones físicas de las señales, como pueden ser el color, resistencia exigida a los materiales utilizados, etc., se estará a lo establecido por el apartado 701 «Señales y carteles verticales de circulación retrorreflectantes» del *Pliego de prescripciones técnicas generales para obras de carreteras y puentes (PG-3)* vigente.



## **DIMENSIONES DE LAS SEÑALES VERTICALES DE CIRCULACIÓN**

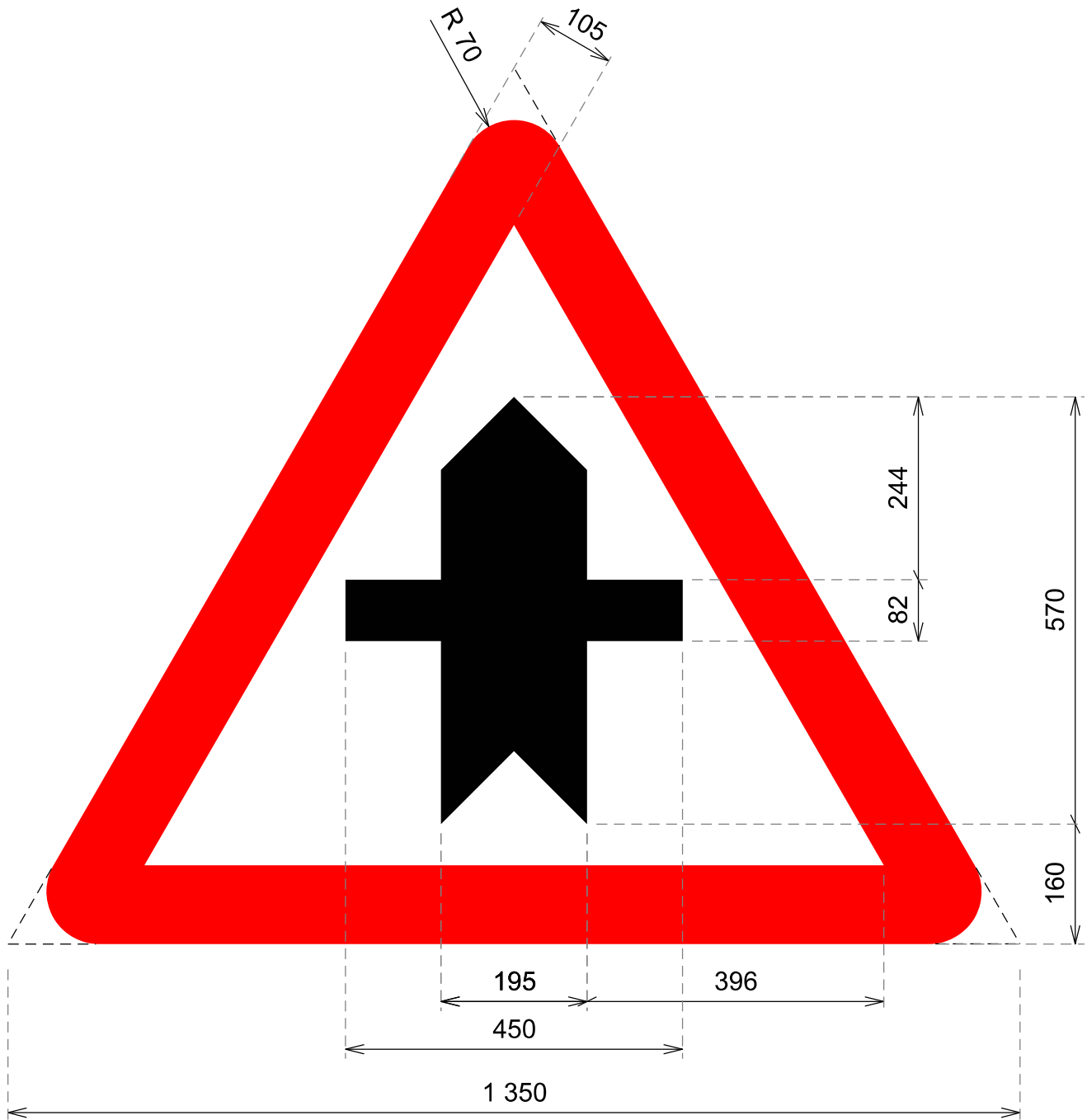

cotas en mm

Intersección con prioridad

**P-1**

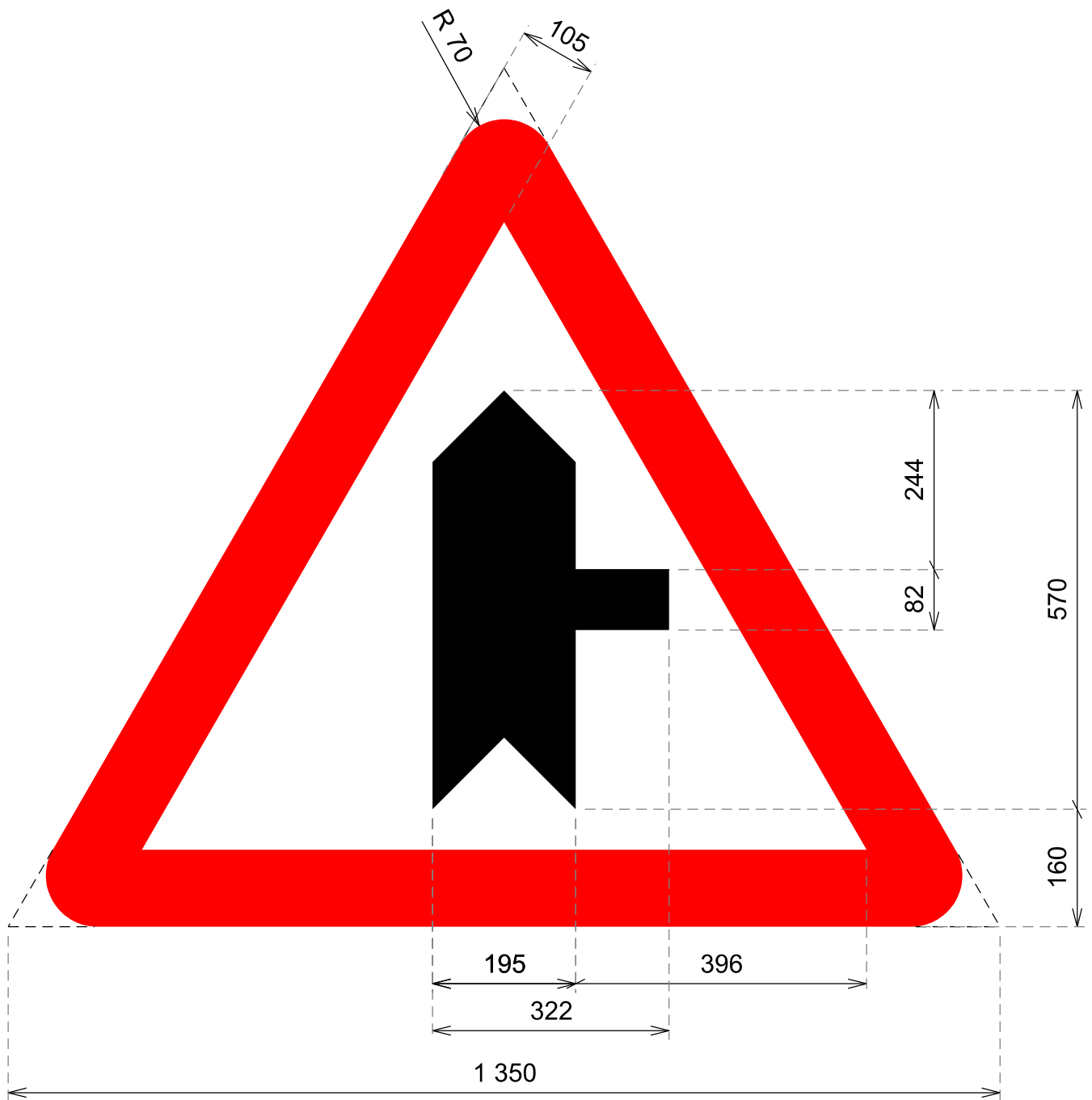

cotas en mm

Intersección con prioridad sobre vía a la derecha

**P-1a**

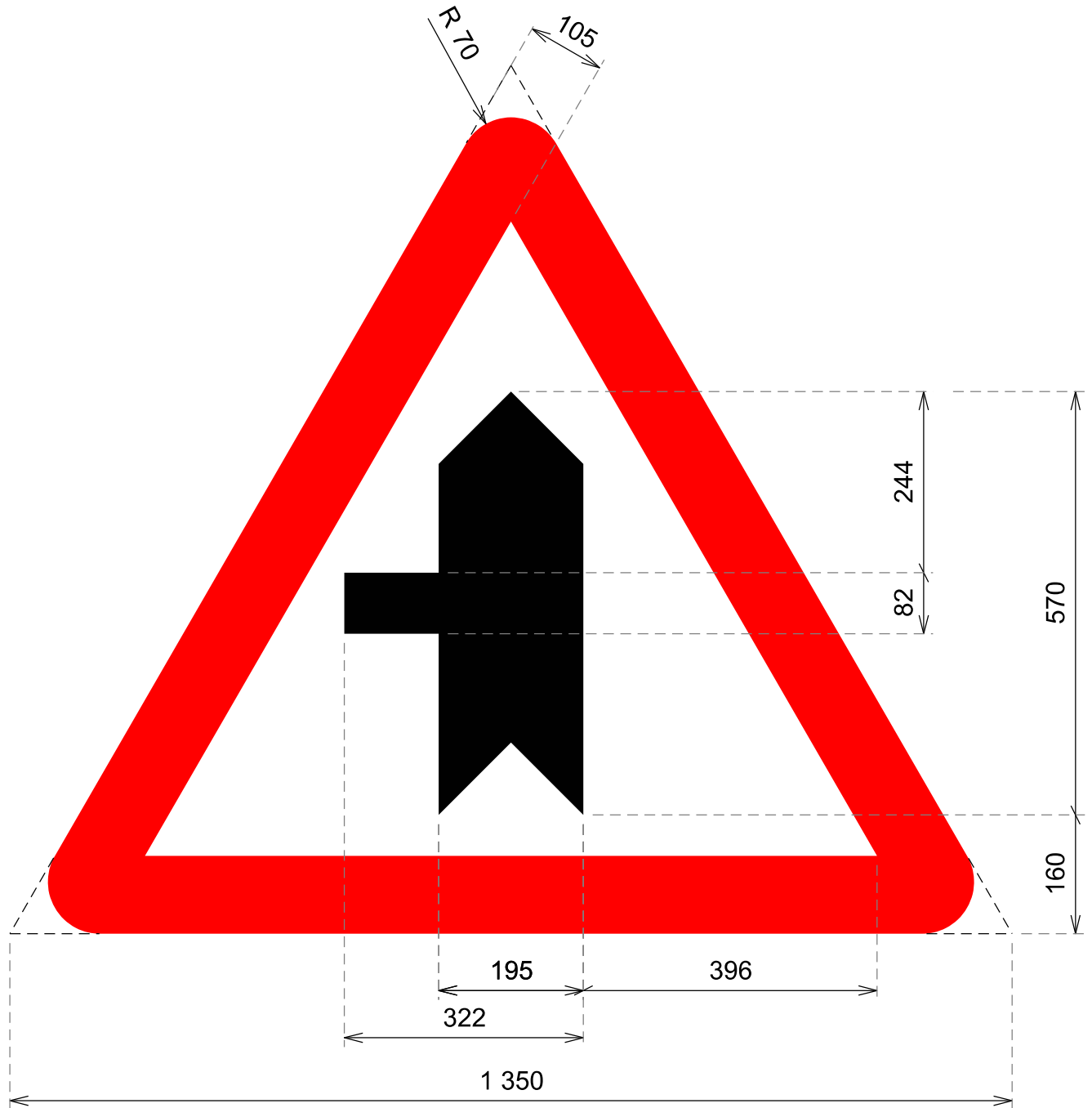

cotas en mm

Intersección con prioridad sobre vía a la izquierda

**P-1b**



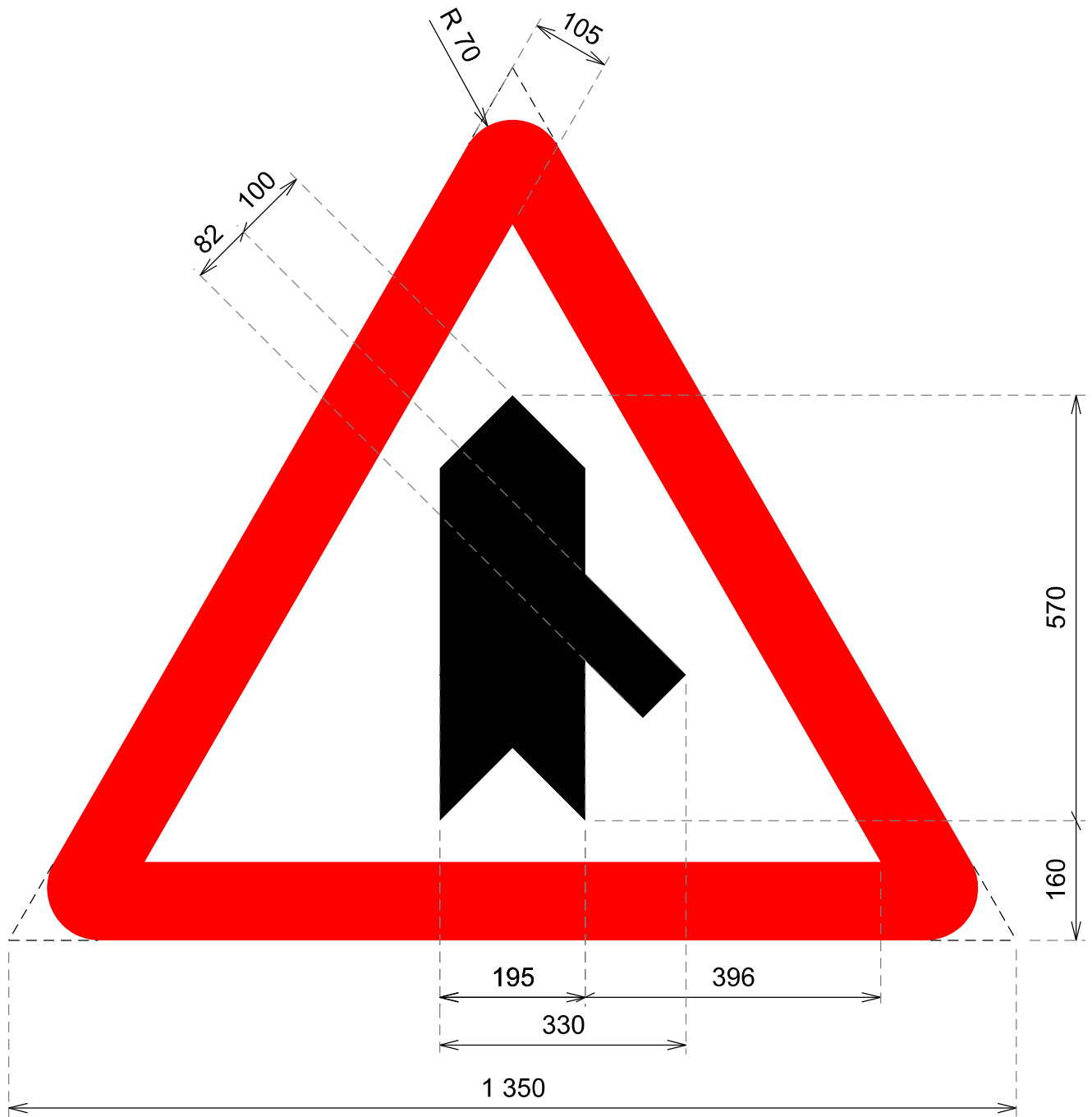

cotas en mm

Intersección con prioridad sobre  
incorporación por la derecha

**P-1c**

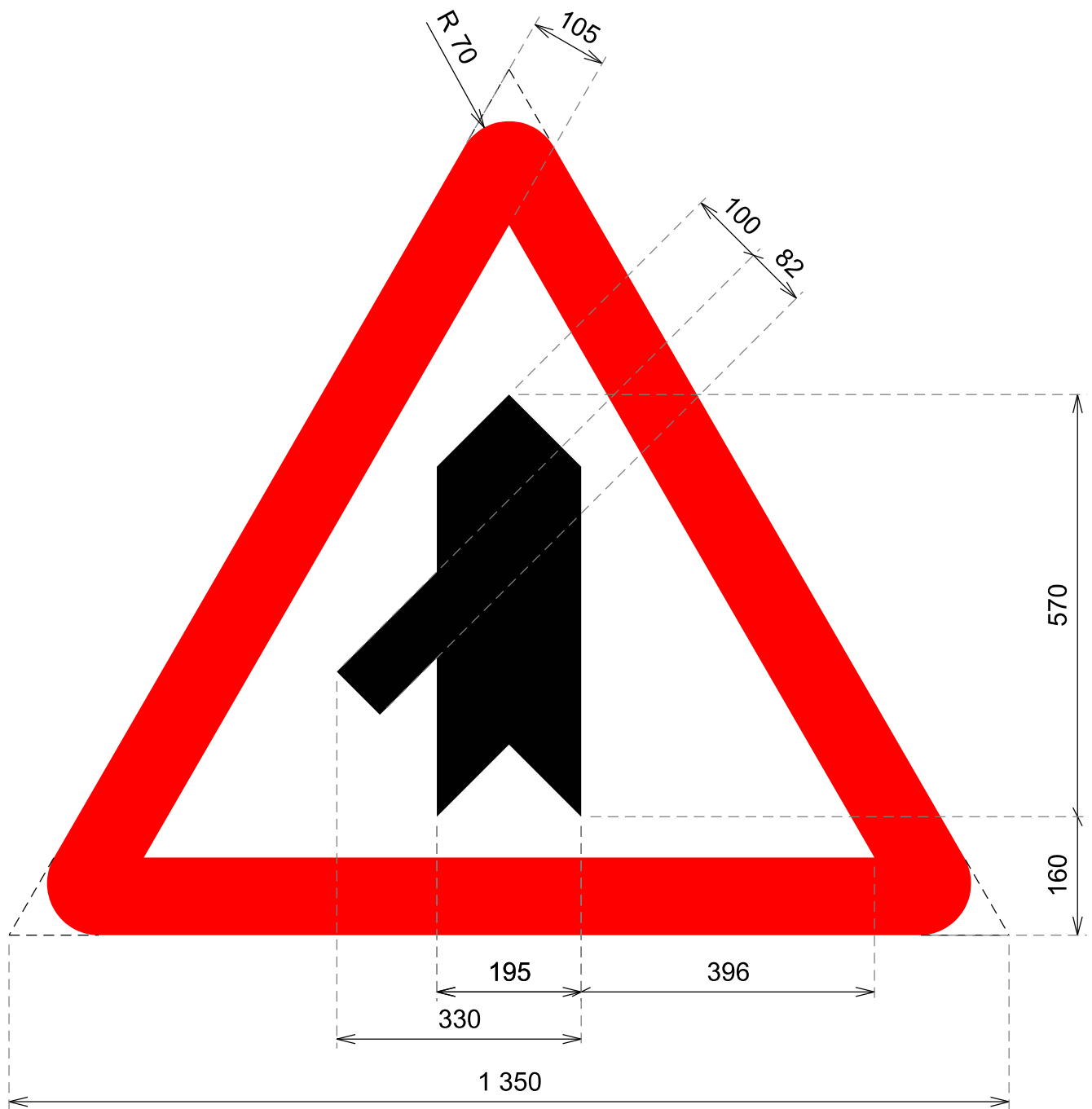

cotas en mm

Intersección con prioridad sobre  
incorporación por la izquierda

**P-1d**

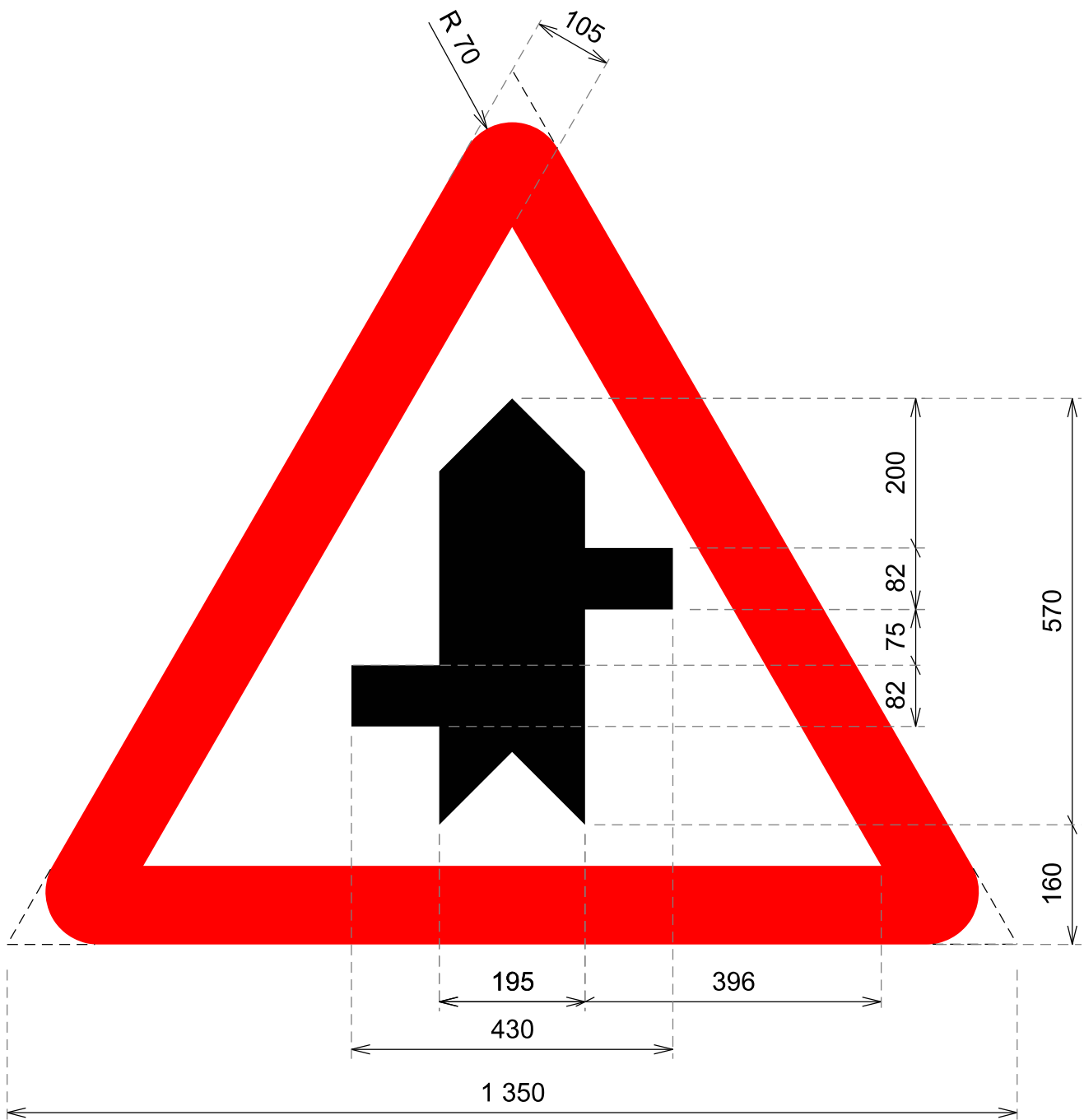

cotas en mm

Tramo con accesos directos

**P-1e**

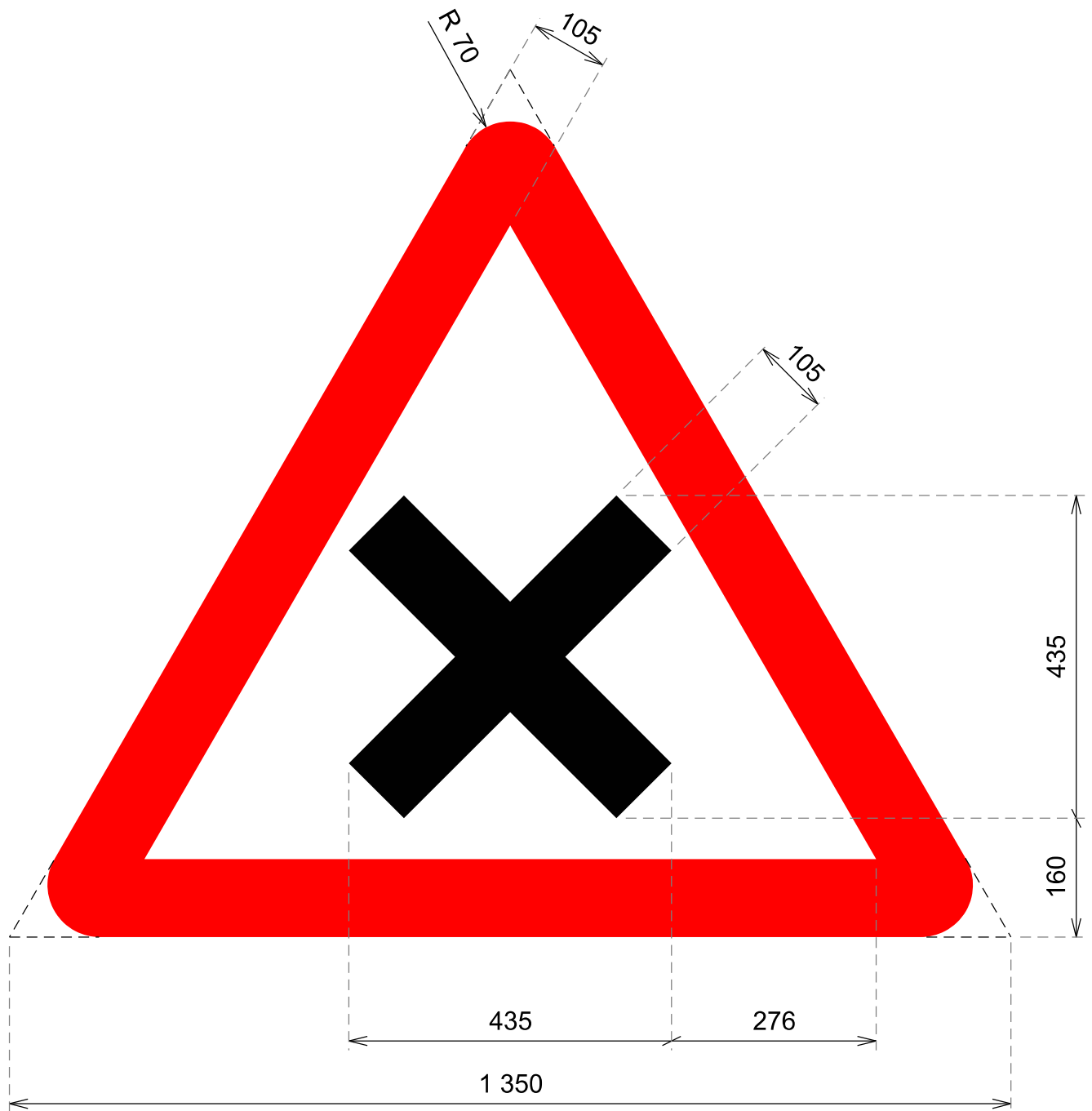

cotas en mm

Intersección con prioridad de la derecha

**P-2**

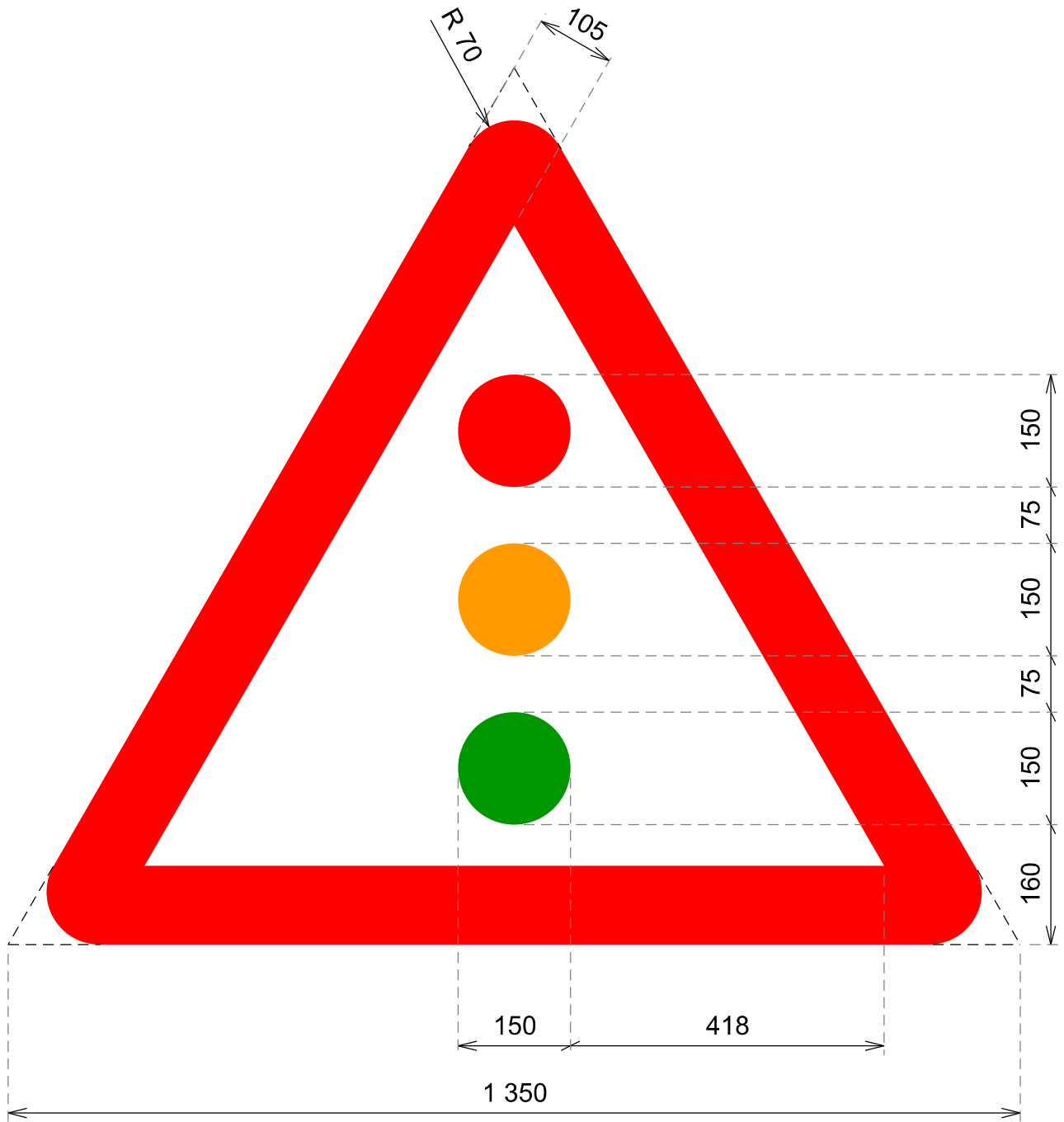

cotas en mm

Semáforos

P-3

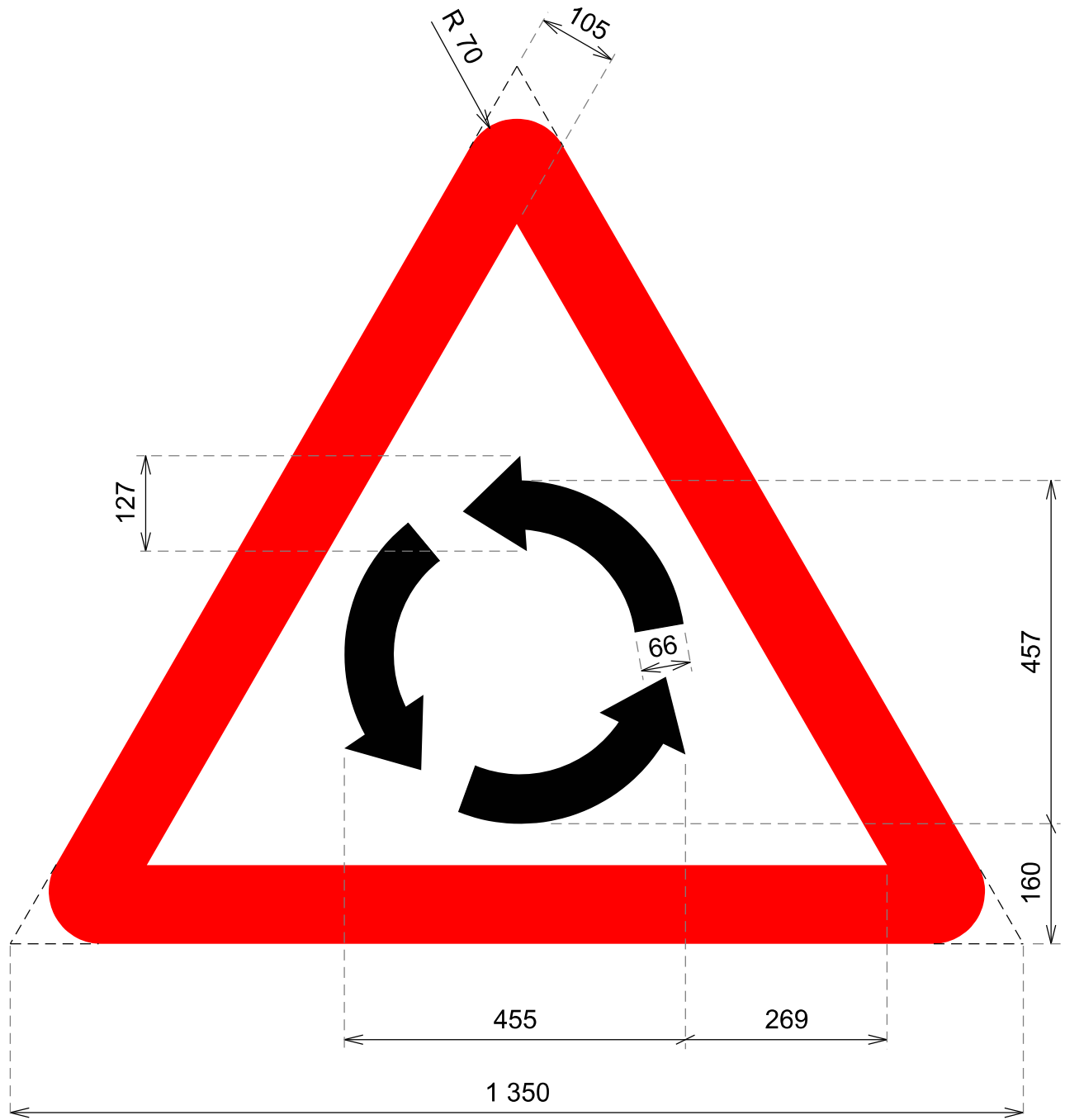

cotas en mm

Glorieta

P-4

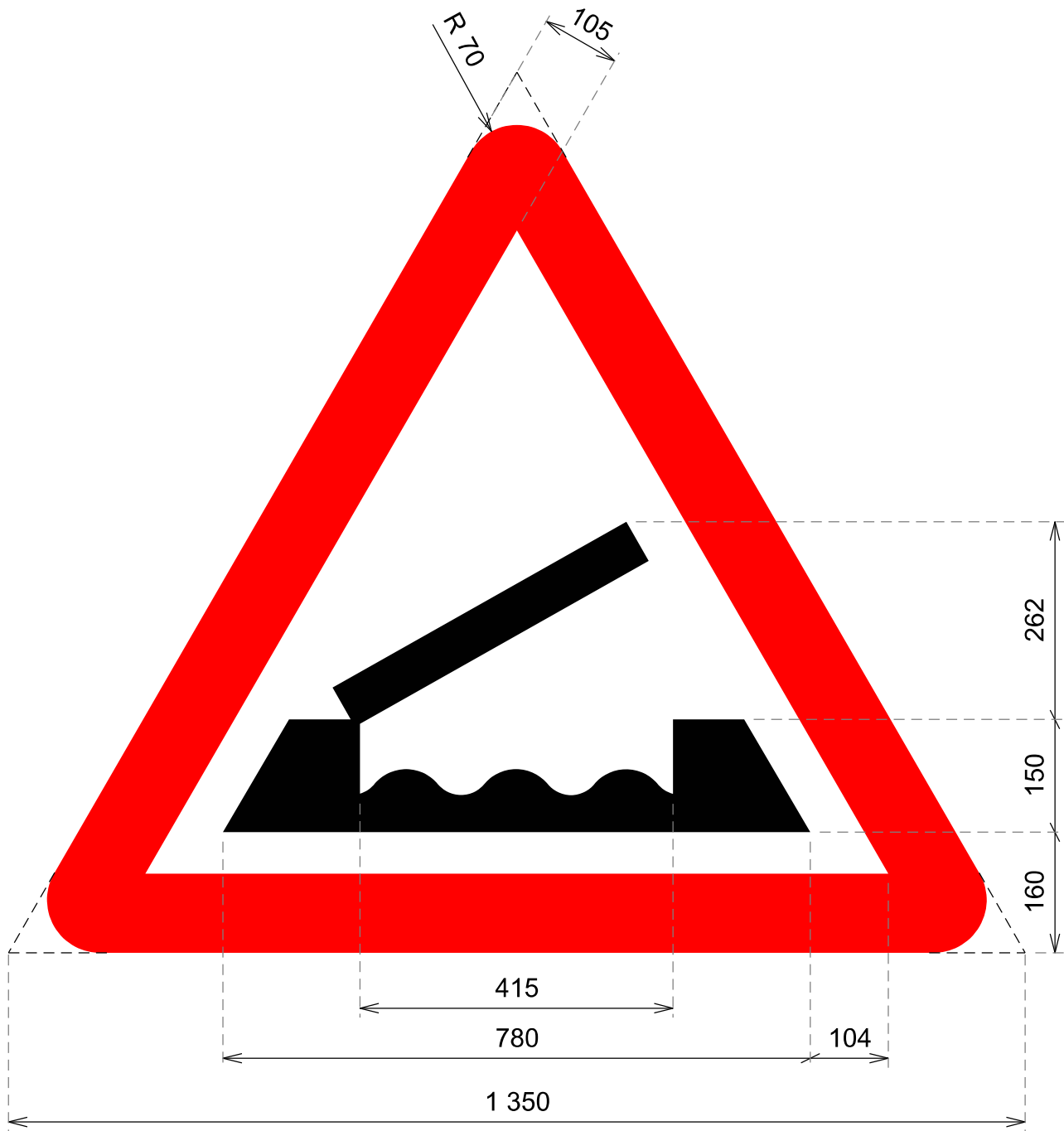

cotas en mm

Puente móvil

**P-5**

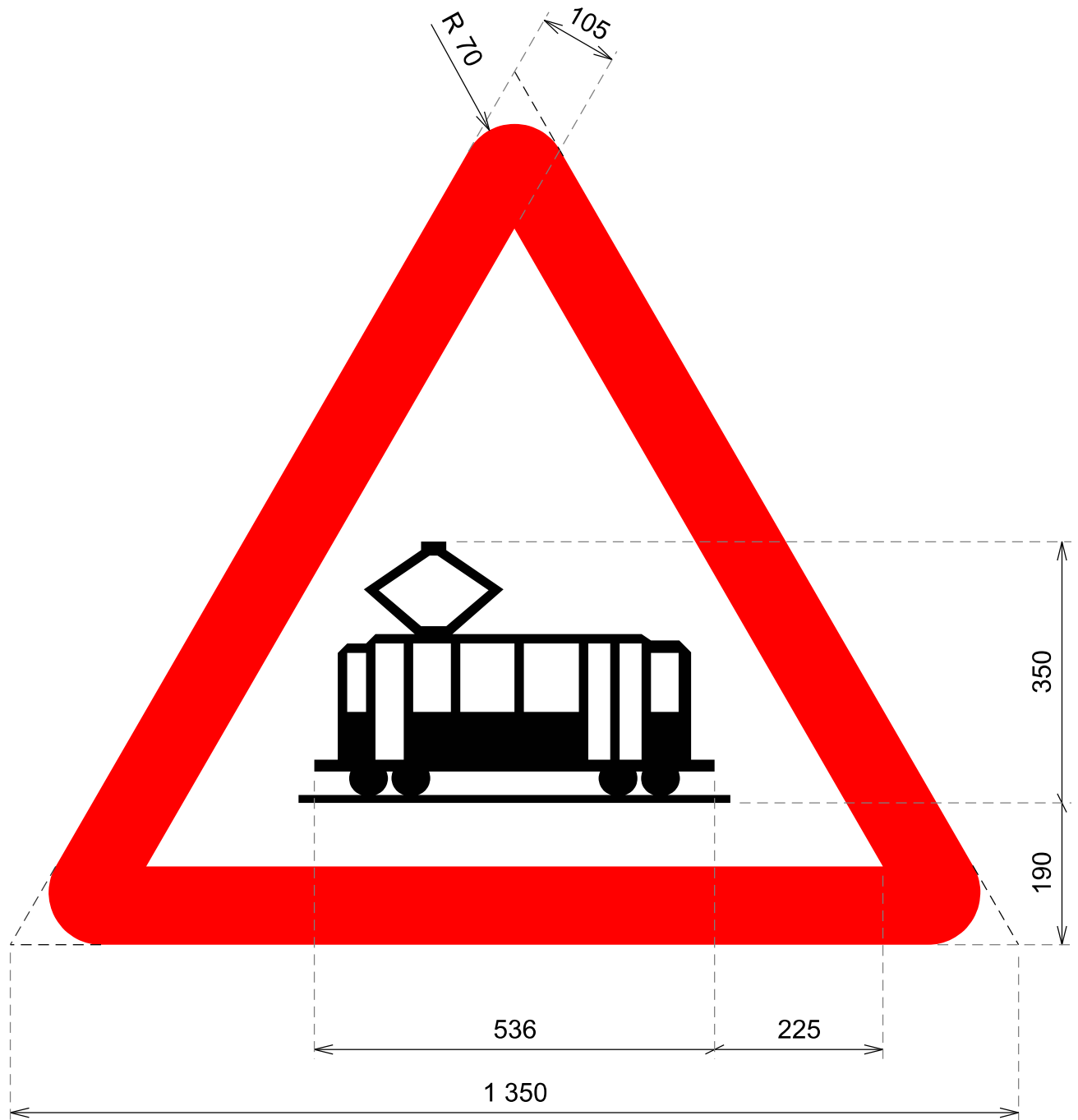

cotas en mm

## Cruce de tranvía

**P-6**



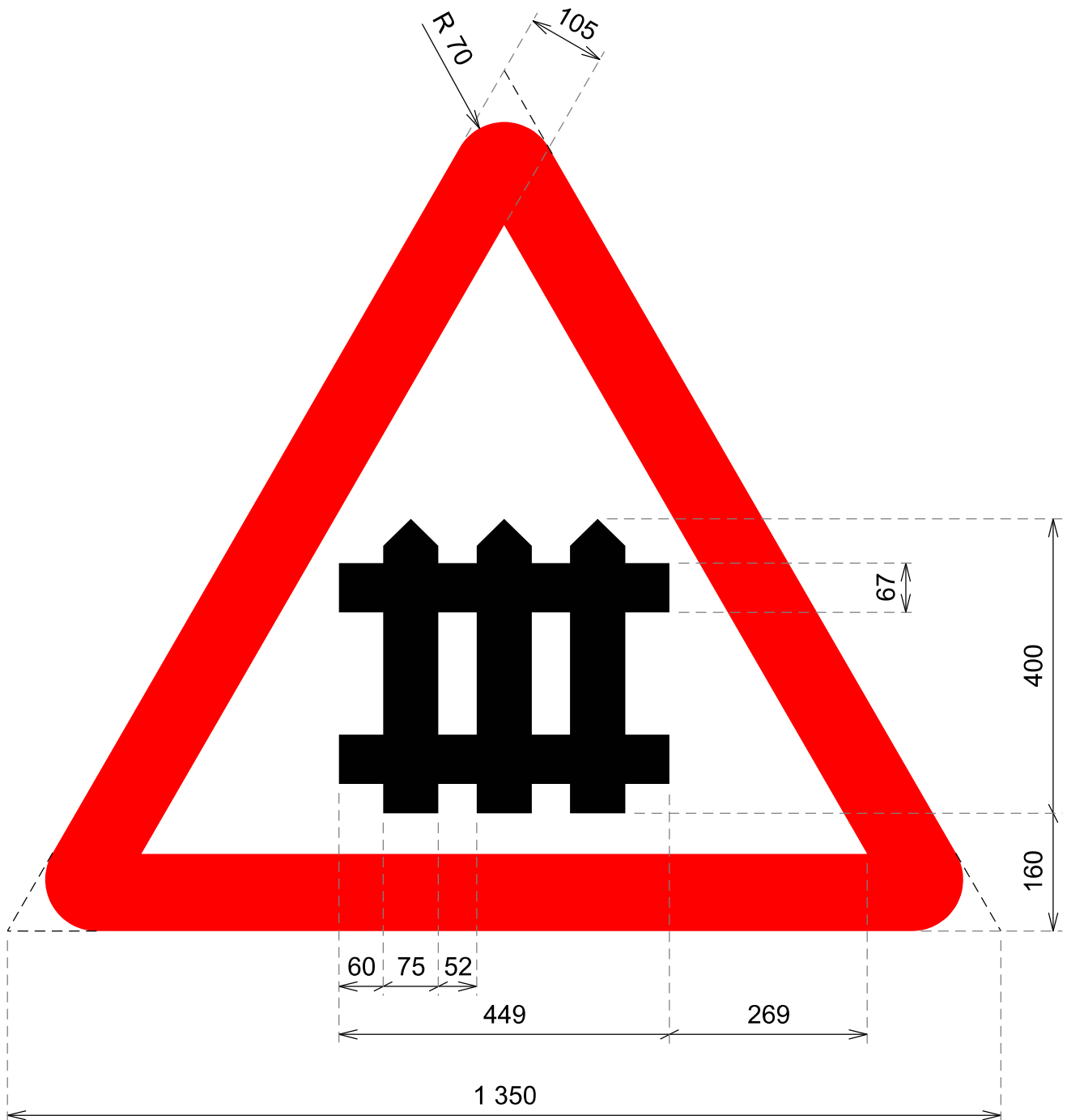

cotas en mm

## Paso a nivel con barreras

## P-7

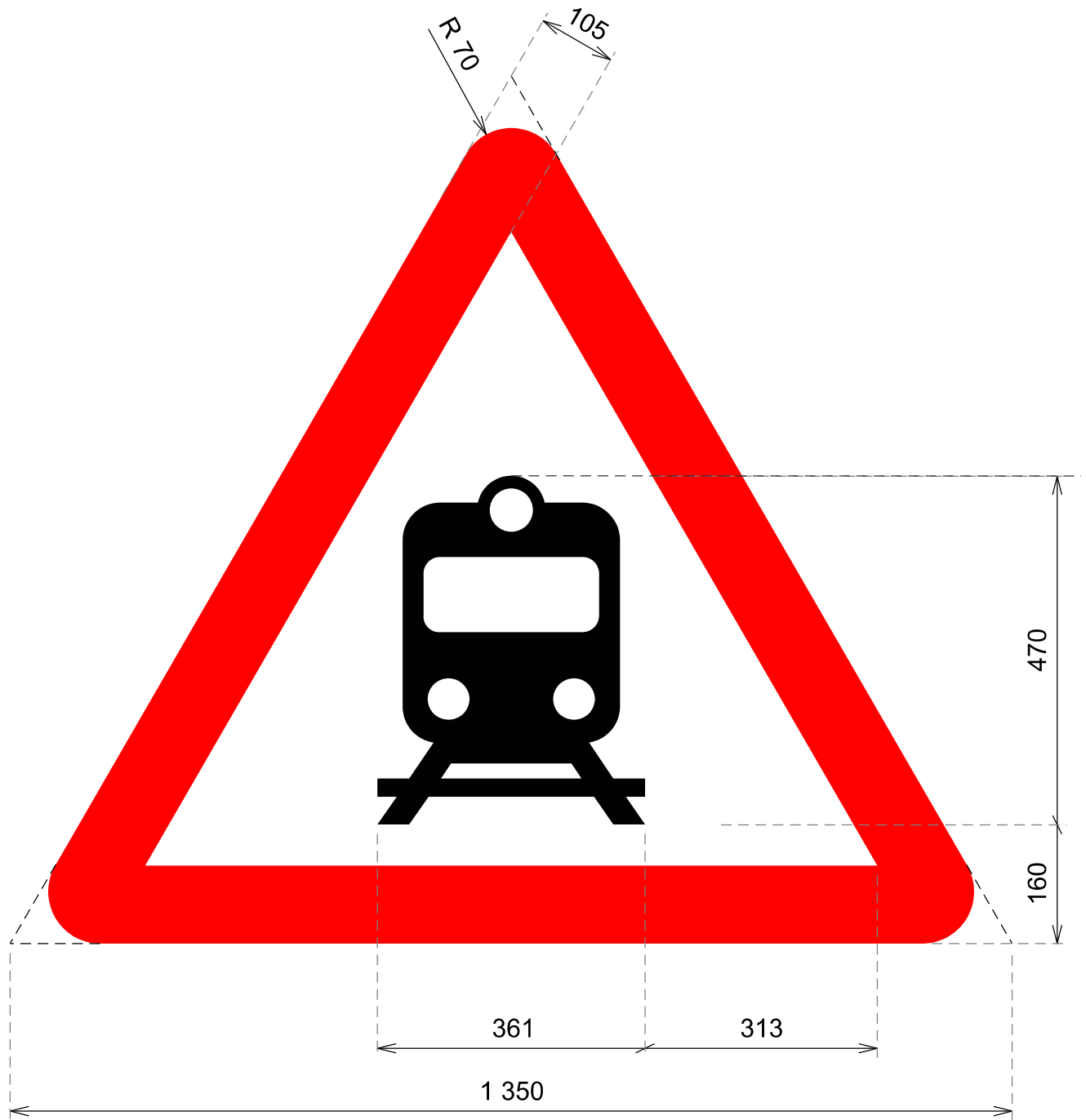

cotas en mm

Paso a nivel sin barreras

**P-8**

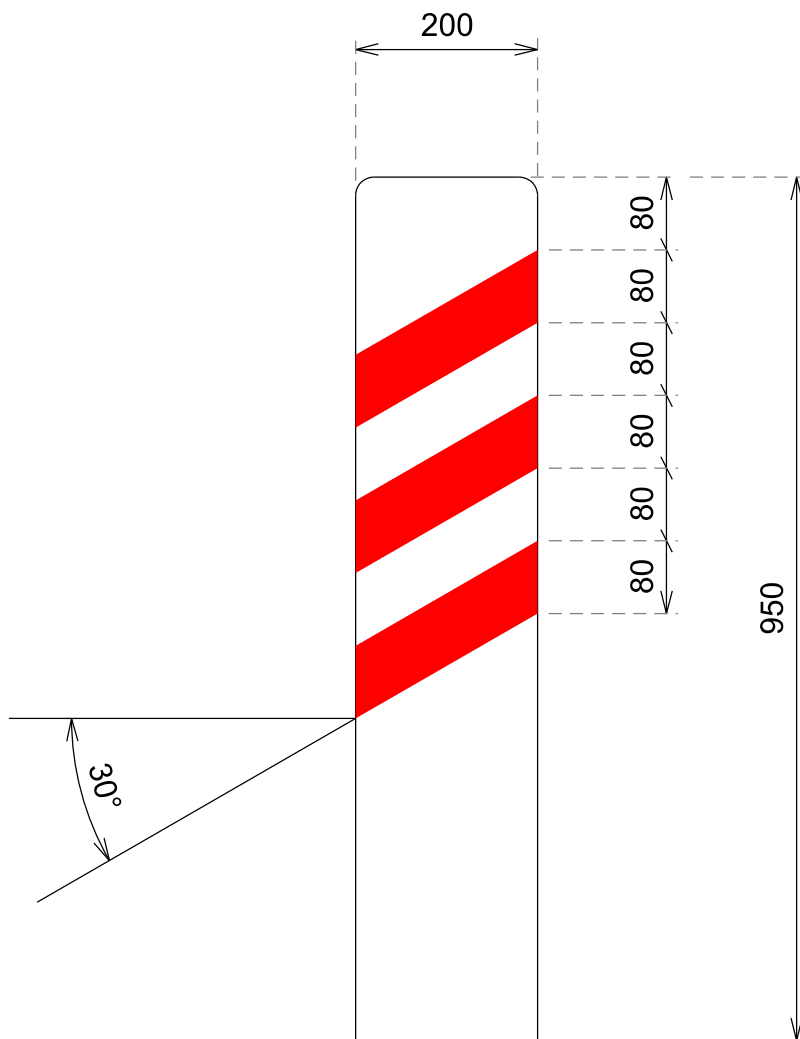

cotas en mm

tamaño único

Aproximación a un paso a nivel, puente móvil o muelle  
(200 m, lado derecho)

**P-9a**

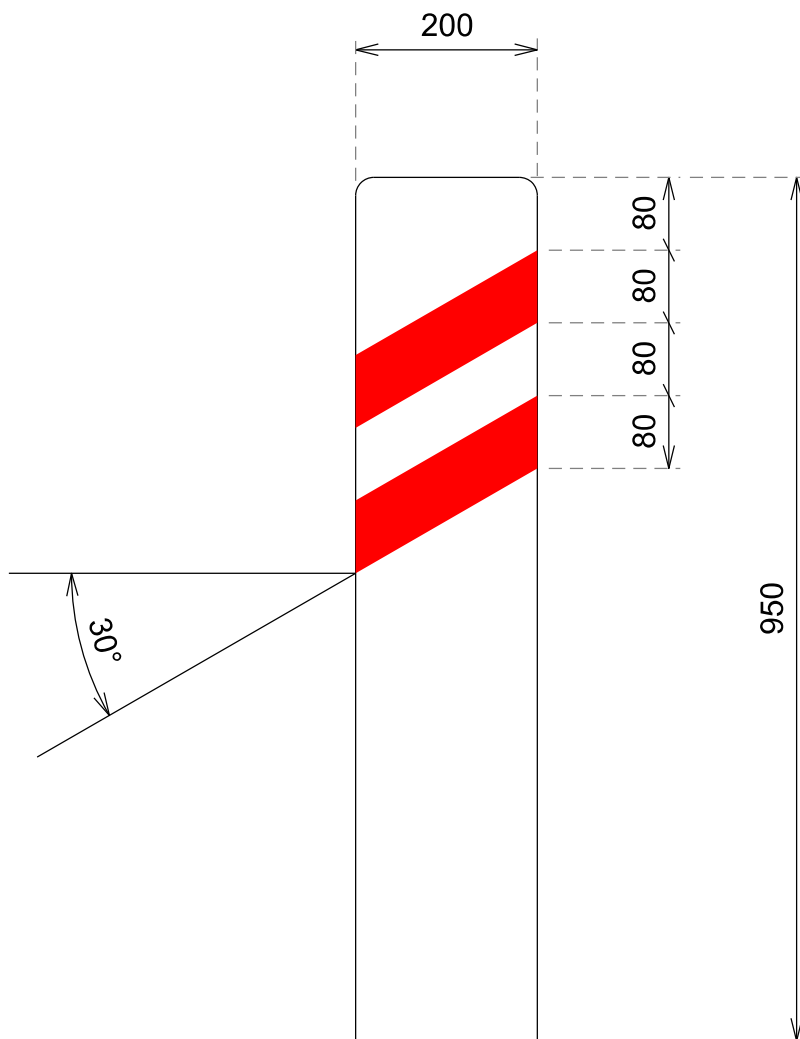

cotas en mm

tamaño único

Aproximación a un paso a nivel, puente móvil o muelle  
(150 m, lado derecho)

**P-9b**

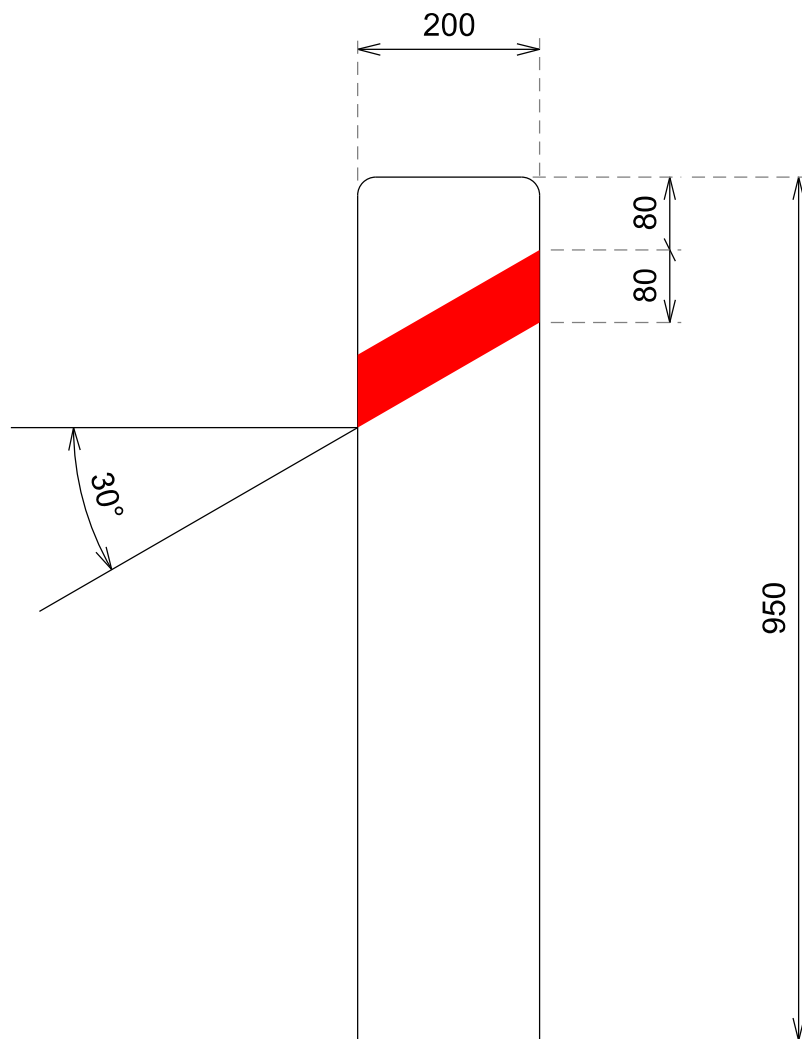

cotas en mm

tamaño único

Aprroximación a un paso a nivel, puente móvil o muelle  
(100 m, lado derecho)

**P-9c**

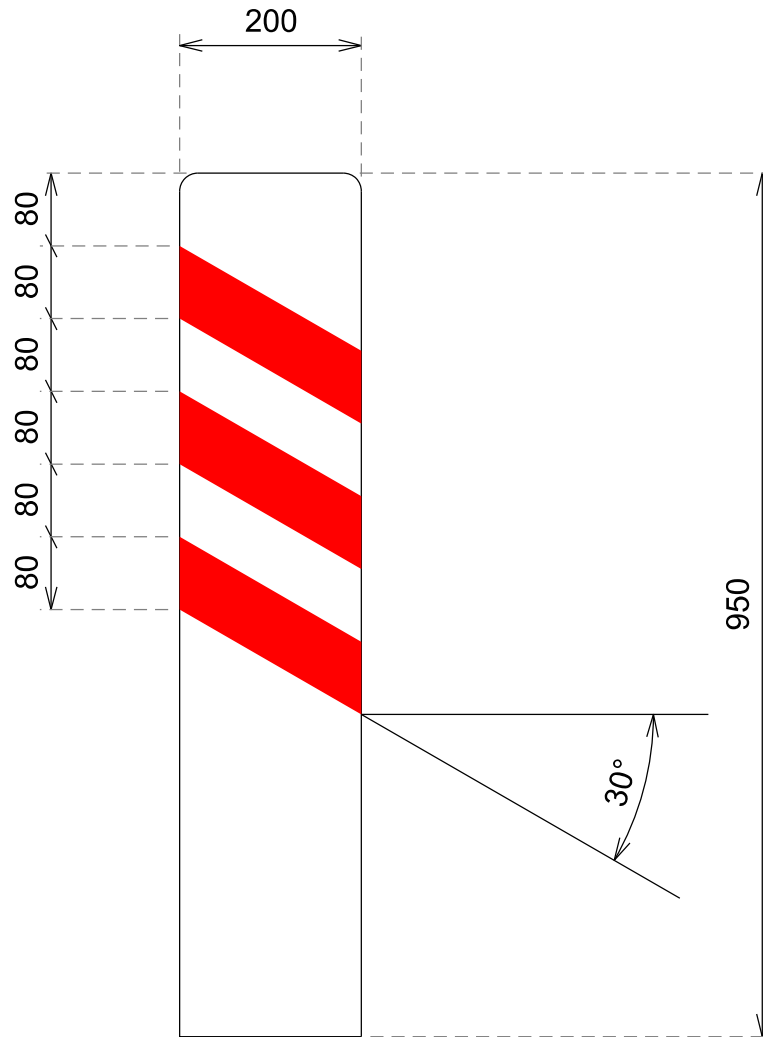

cotas en mm

tamaño único

Aproximación a un paso a nivel, puente móvil o muelle  
(200 m, lado izquierdo)

**P-10a**

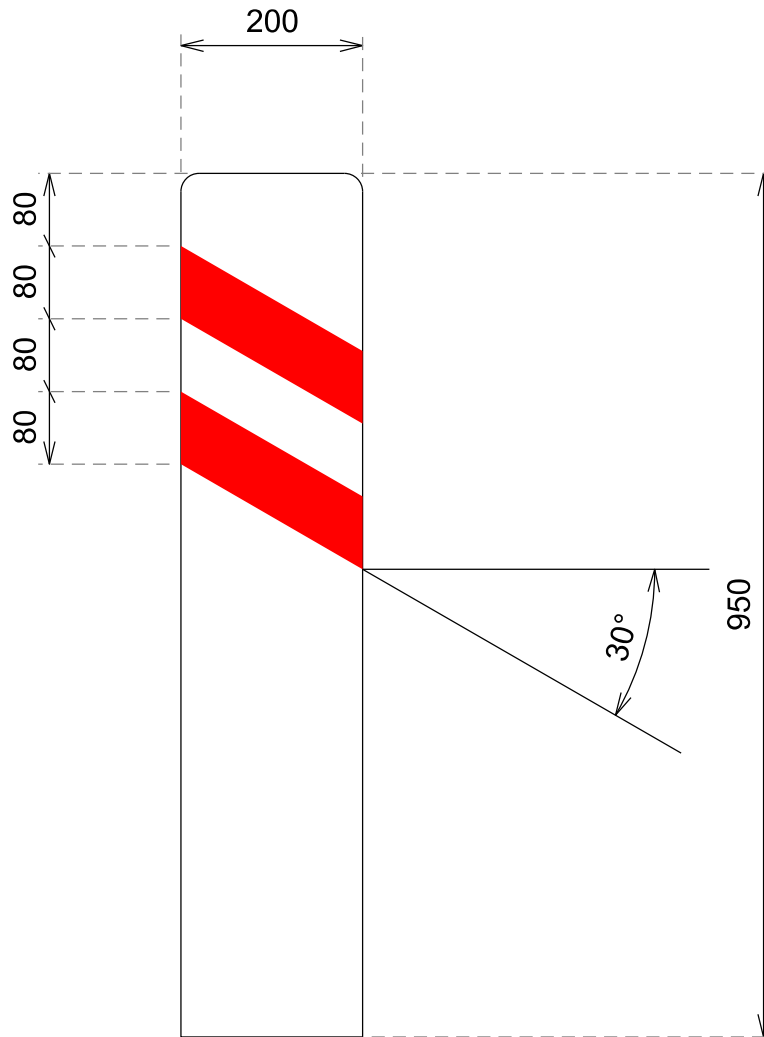

cotas en mm

tamaño único

Aproximación a un paso a nivel, puente móvil o muelle  
(150 m, lado izquierdo)

**P-10b**

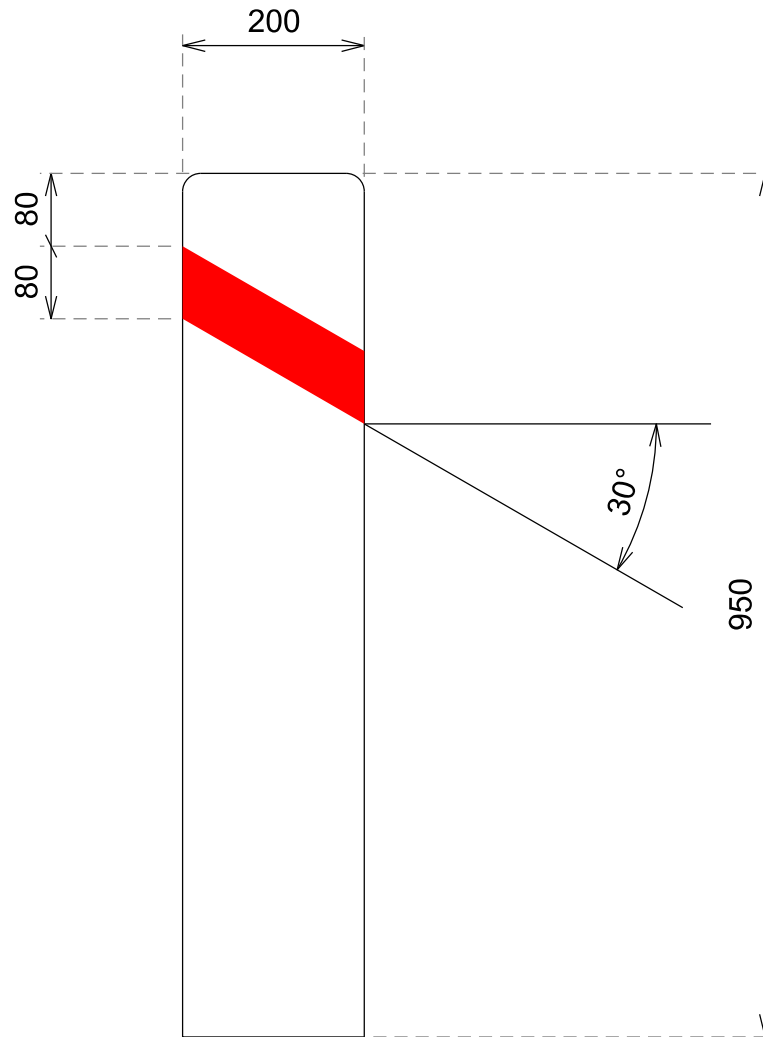

cotas en mm

tamaño único

Aproximación a un paso a nivel, puente móvil o muelle  
(100 m, lado izquierdo)

**P-10c**



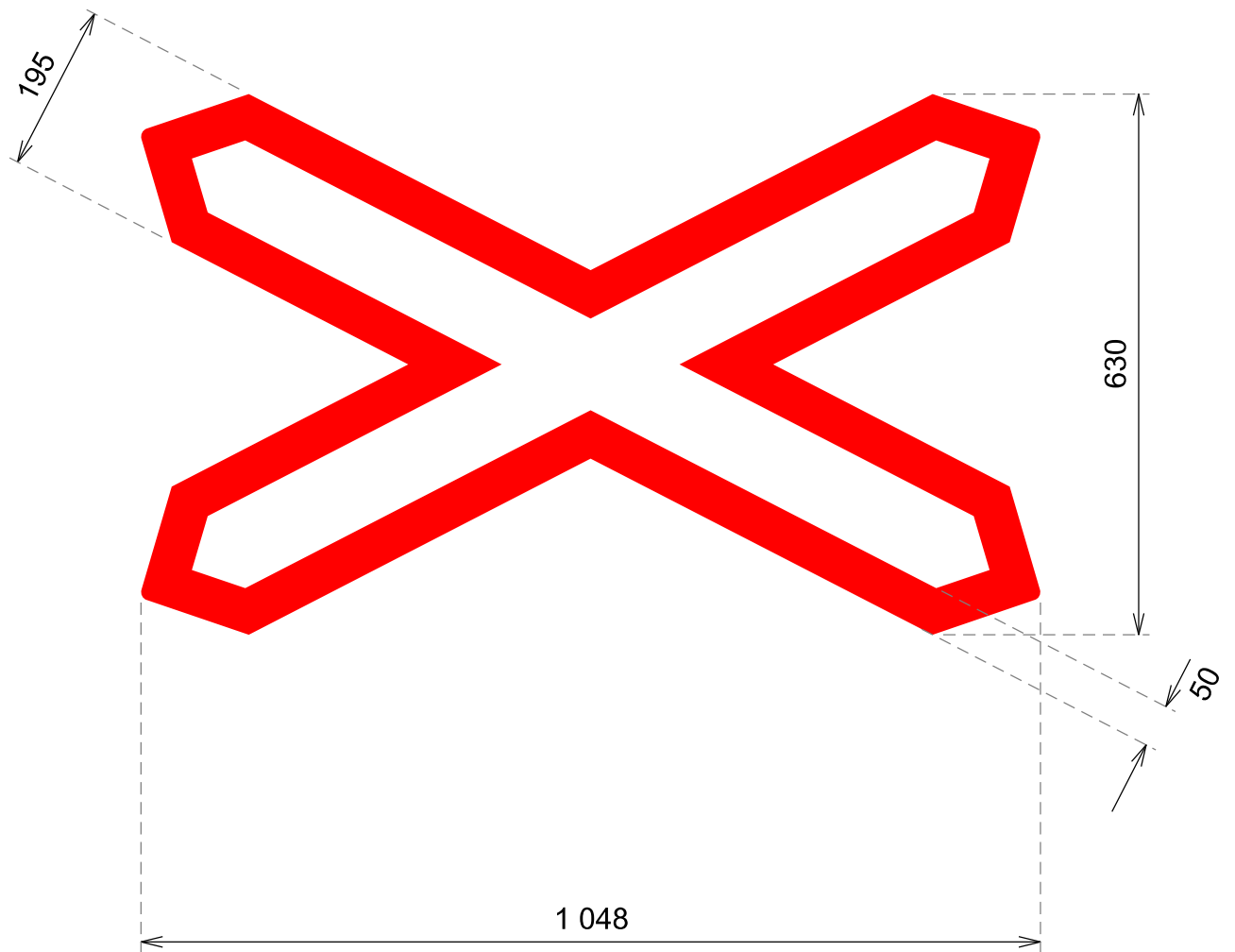

cotas en mm

tamaño único

Situación de un paso a nivel sin barreras

**P-11**



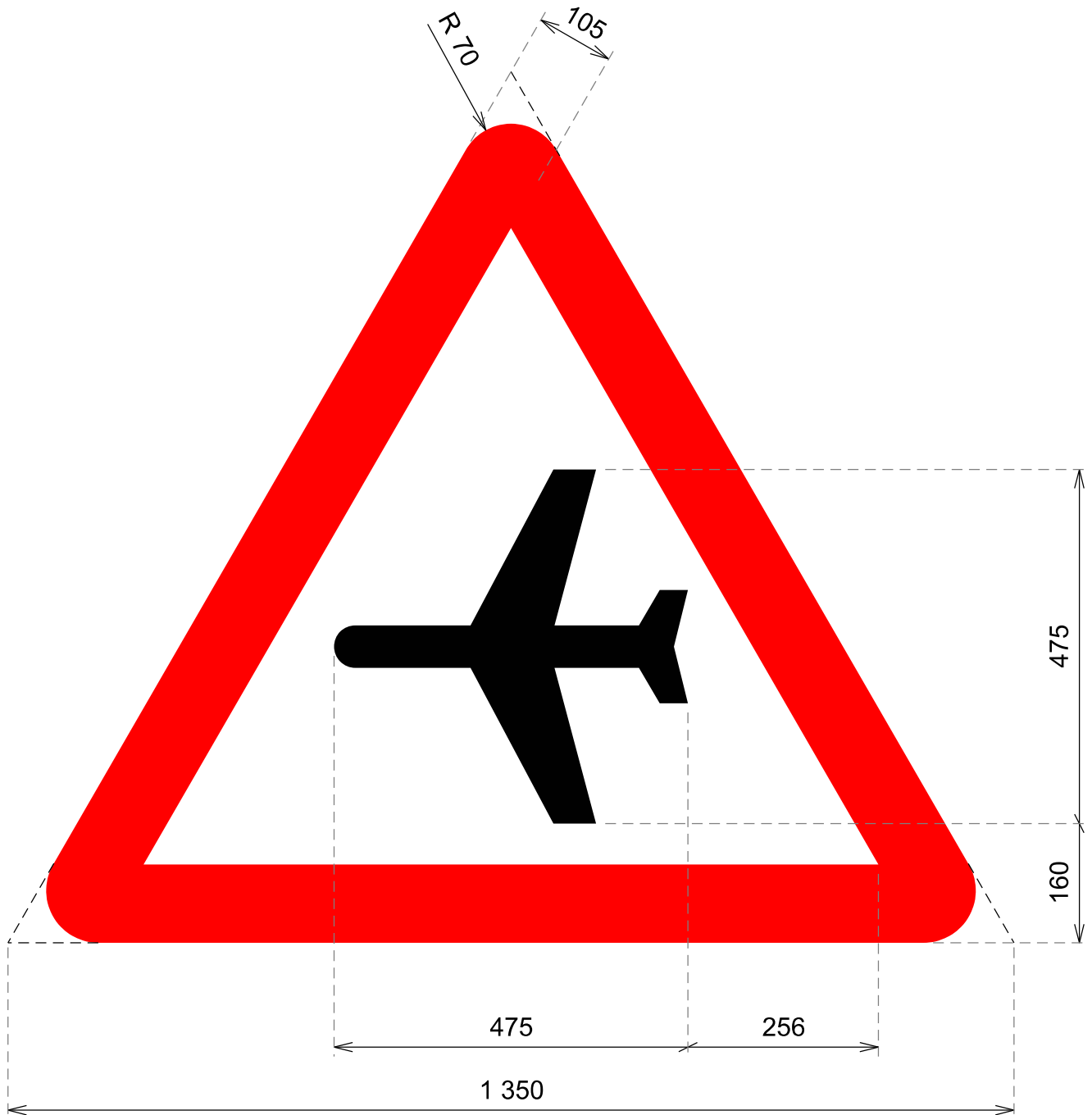

cotas en mm

Aeropuerto

P-12

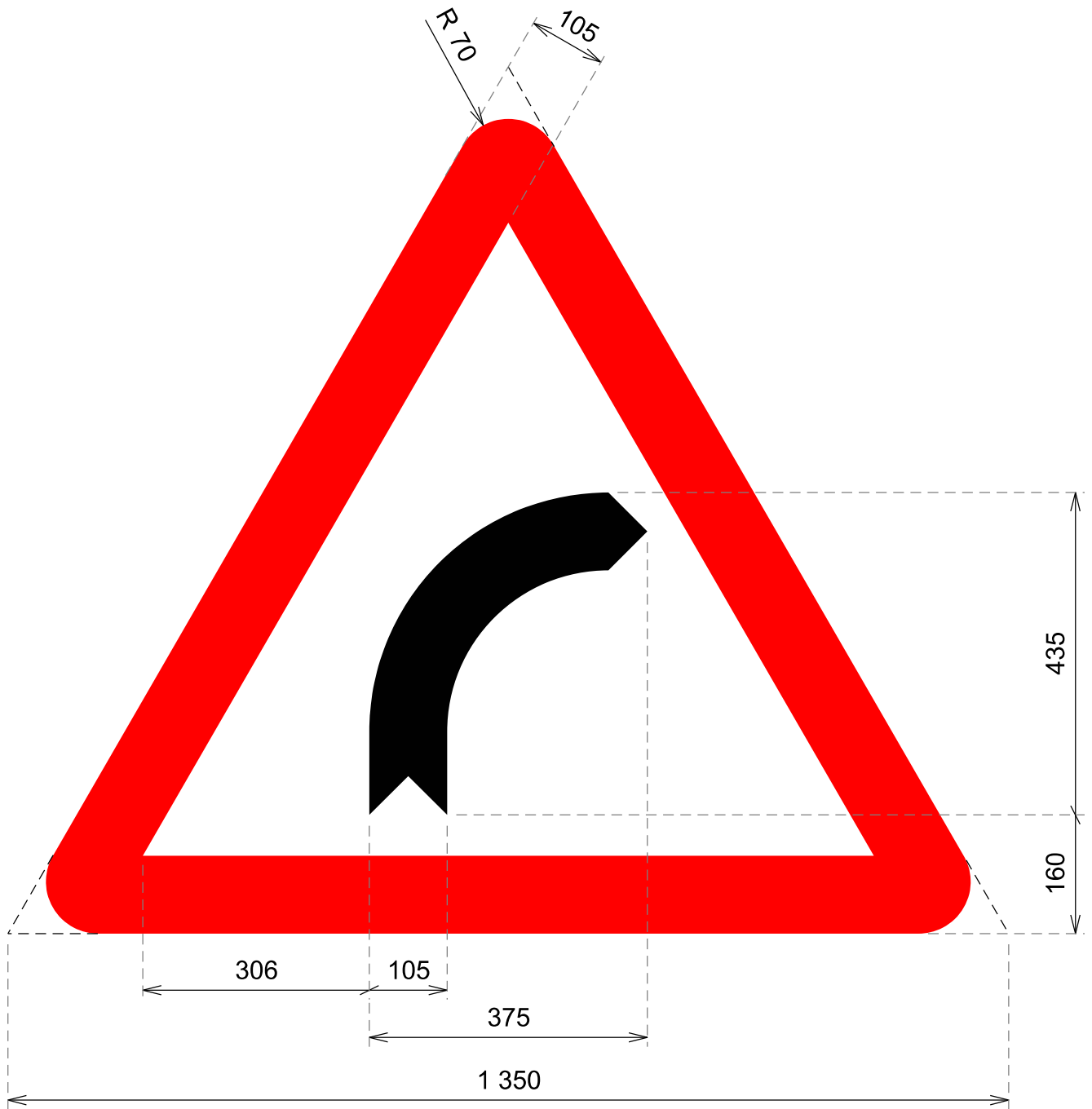

cotas en mm

Curva peligrosa hacia la derecha

**P-13a**

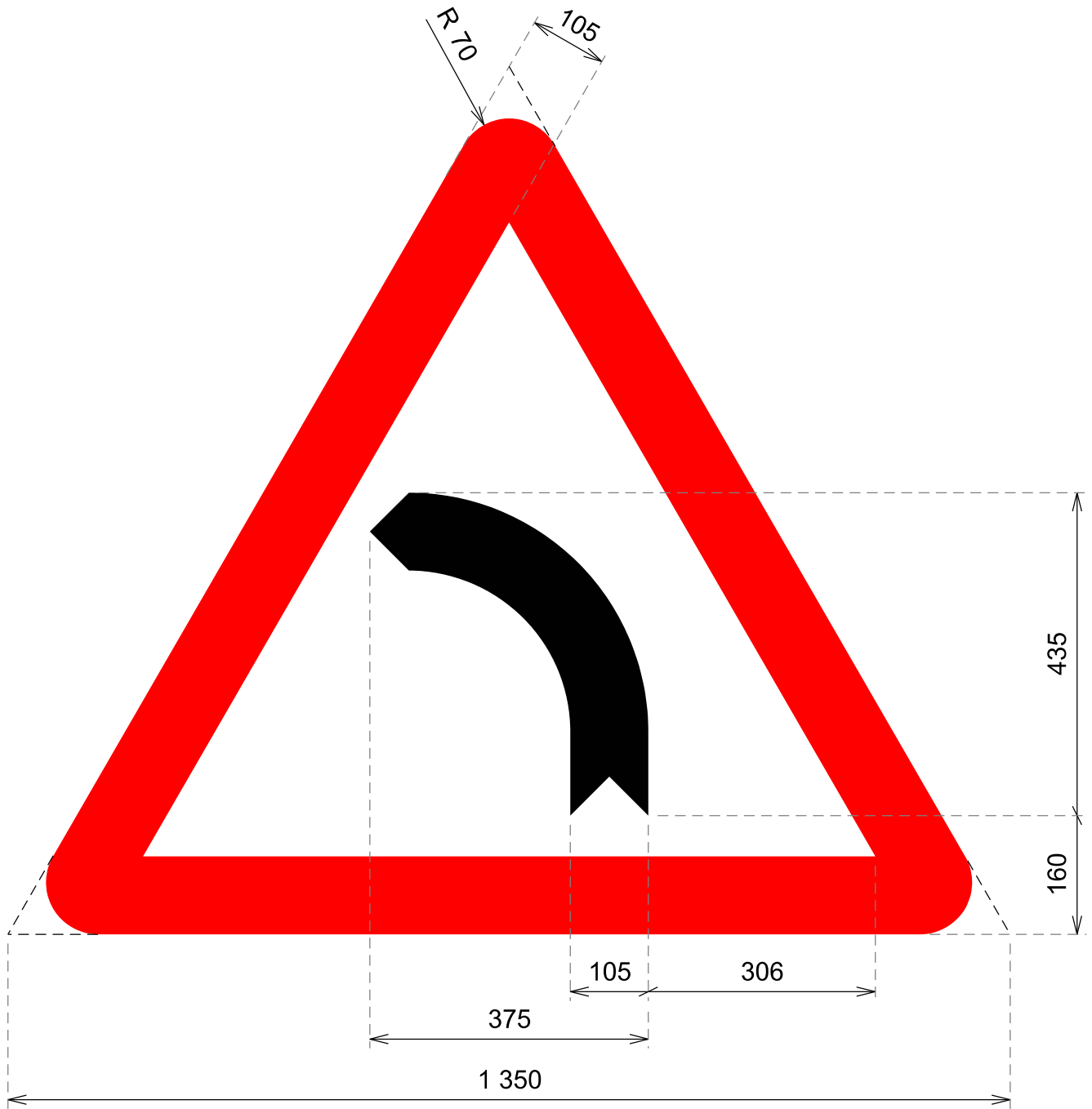

cotas en mm

Curva peligrosa hacia la izquierda

**P-13b**

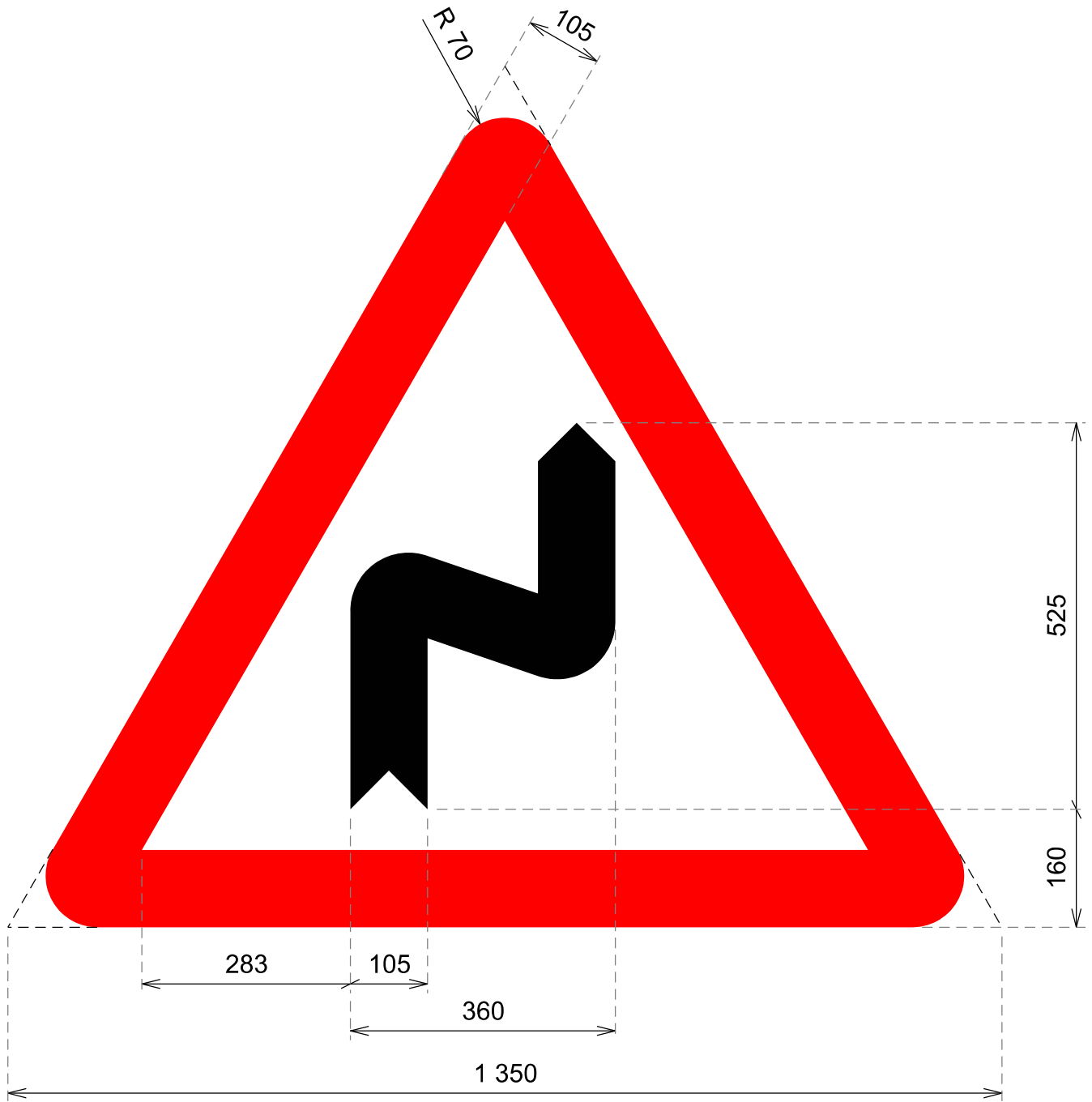

cotas en mm

Curvas peligrosas hacia la derecha

P-14a

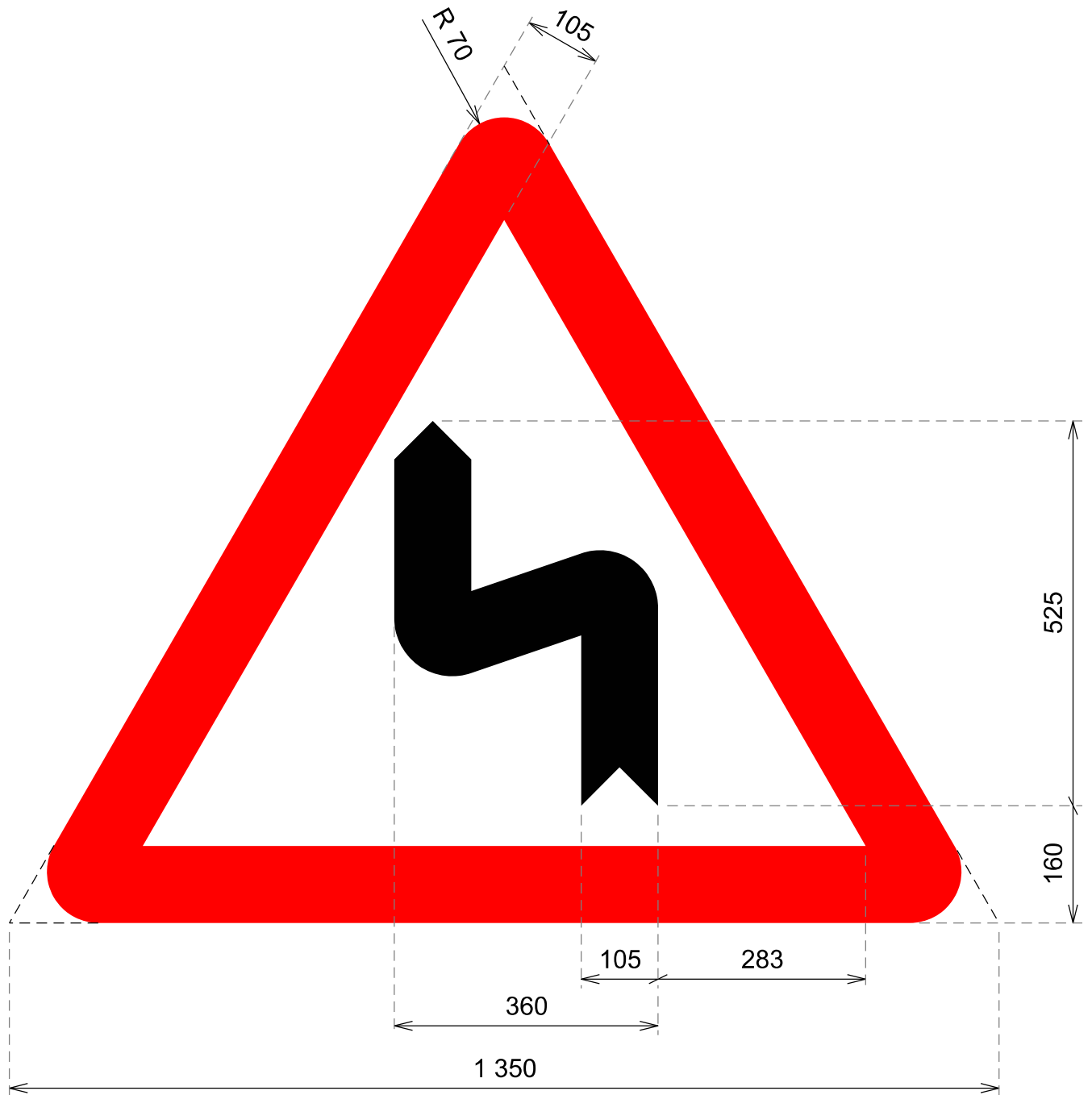

cotas en mm

Curvas peligrosas hacia la izquierda

**P-14b**

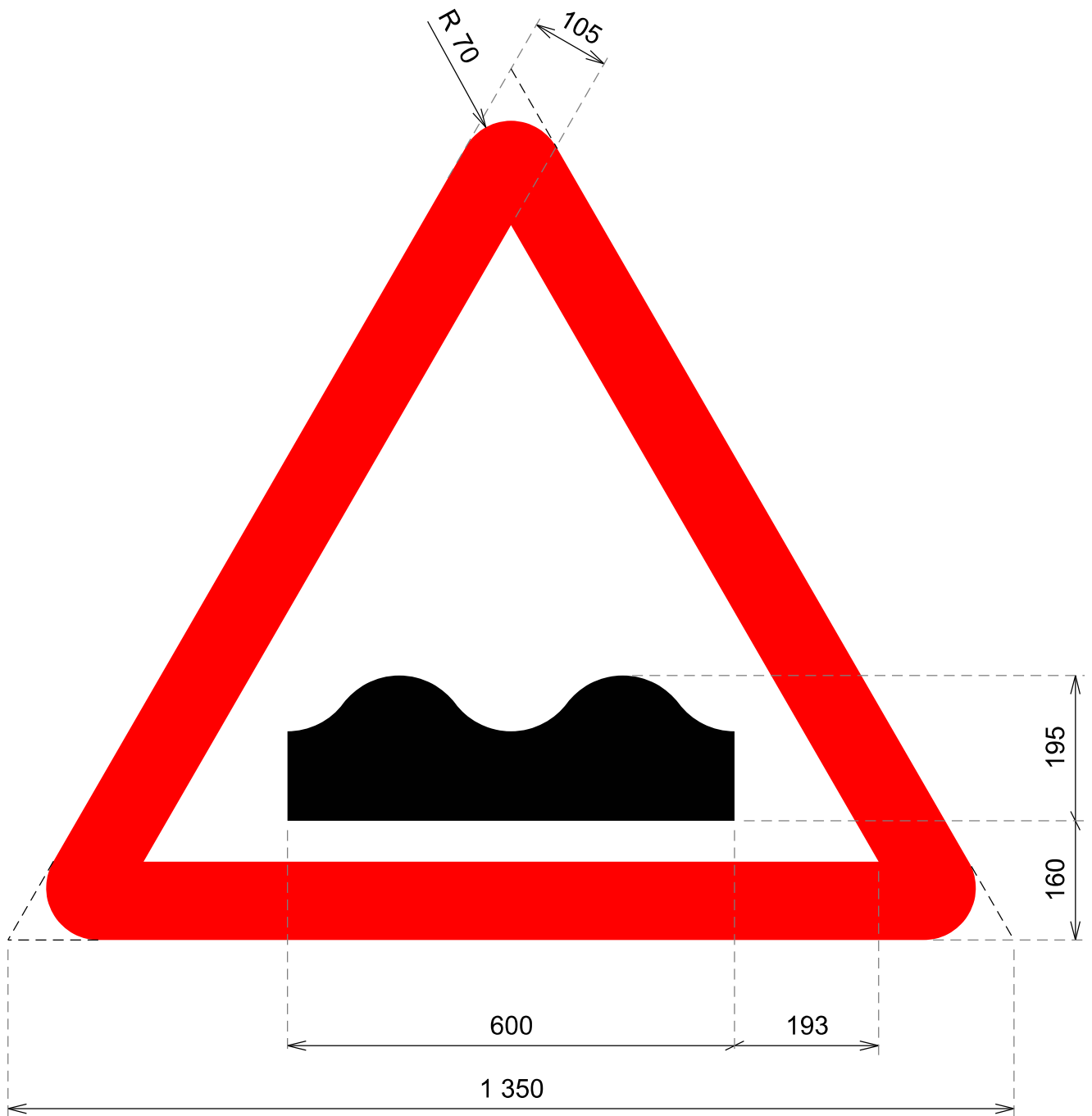

cotas en mm

Perfil irregular

**P-15**



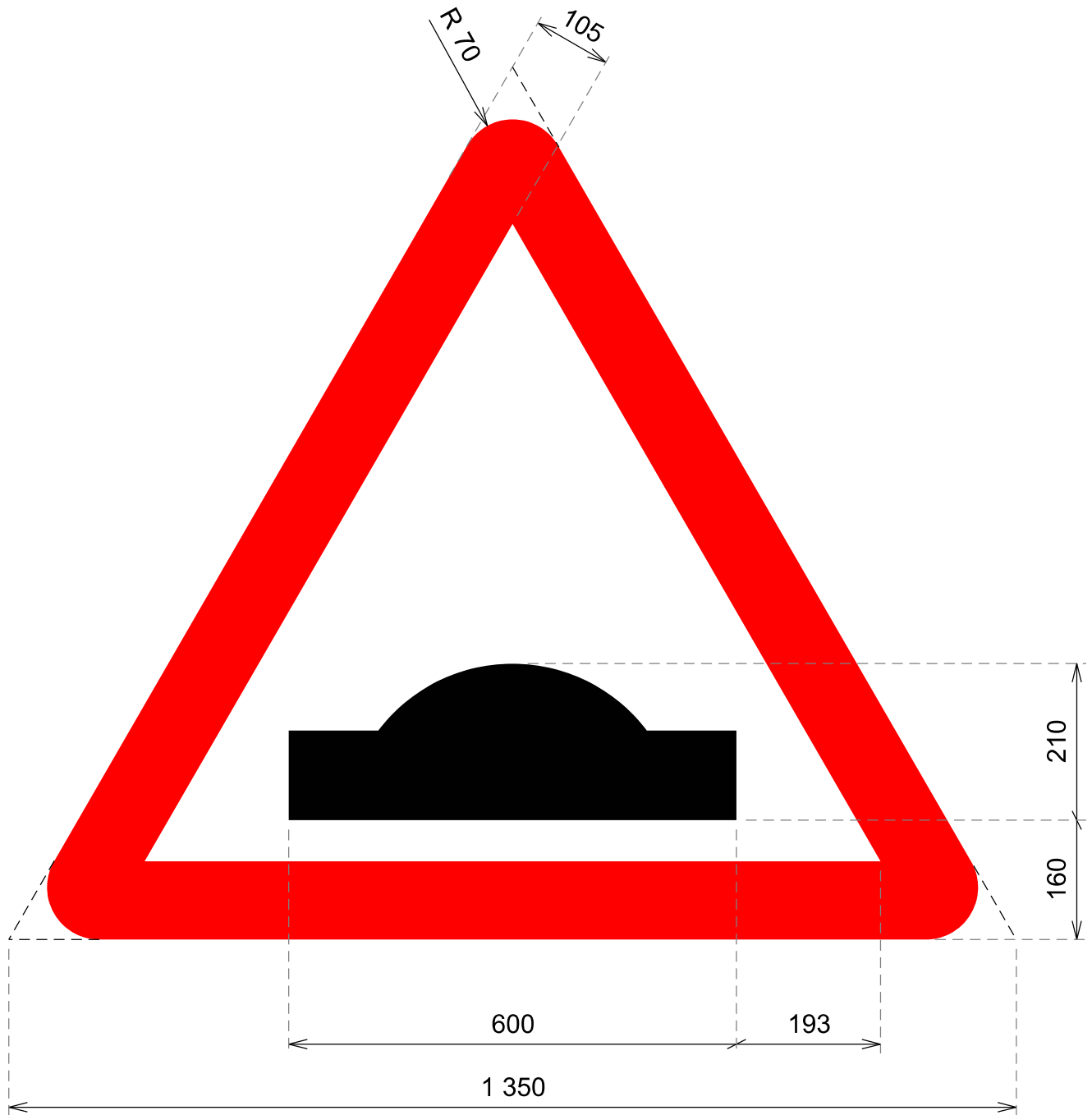

cotas en mm

Resalte

P-15a

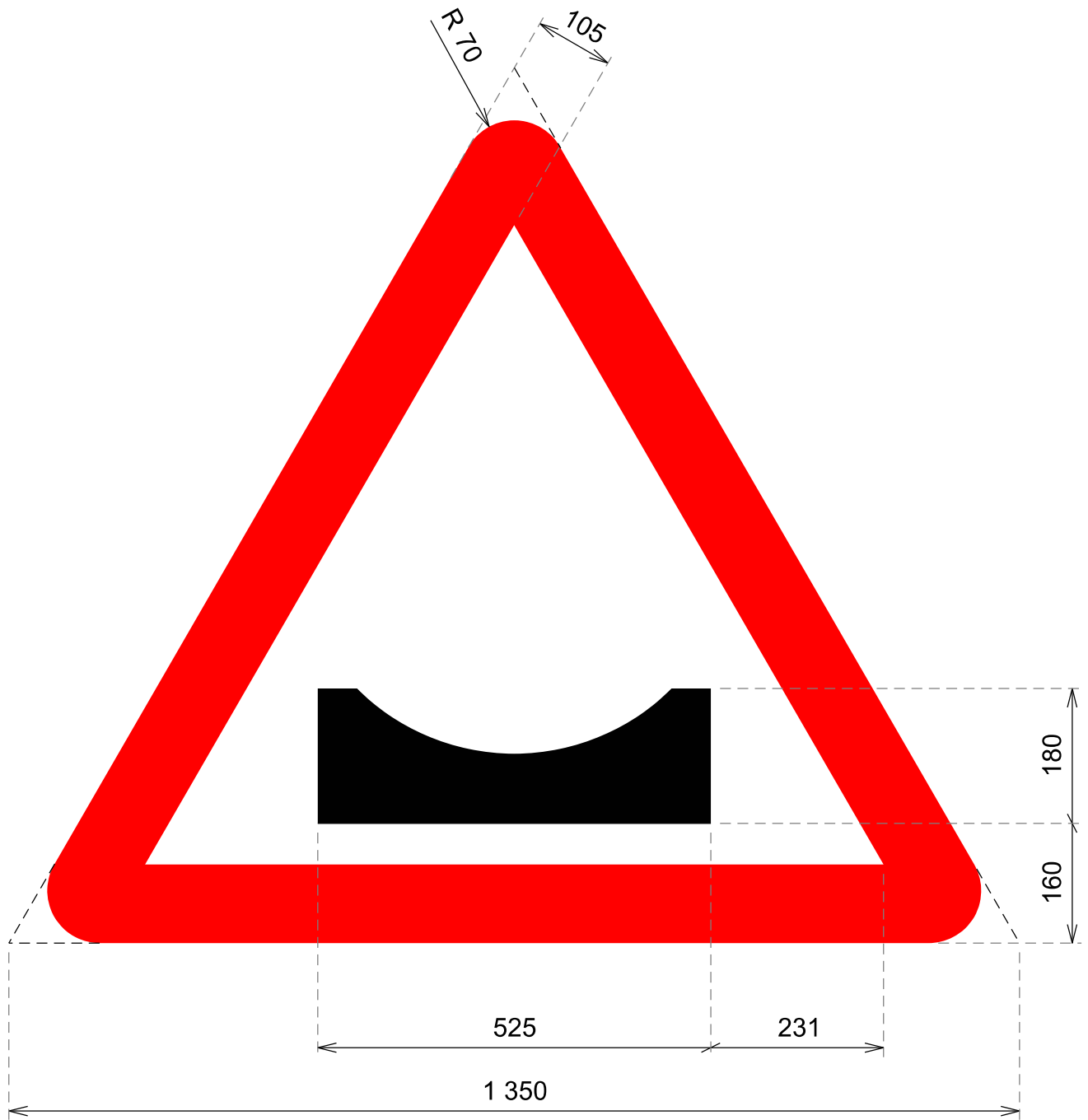

cotas en mm

Badén

P-15b



cotas en mm

Bajada con fuerte pendiente

P-16a

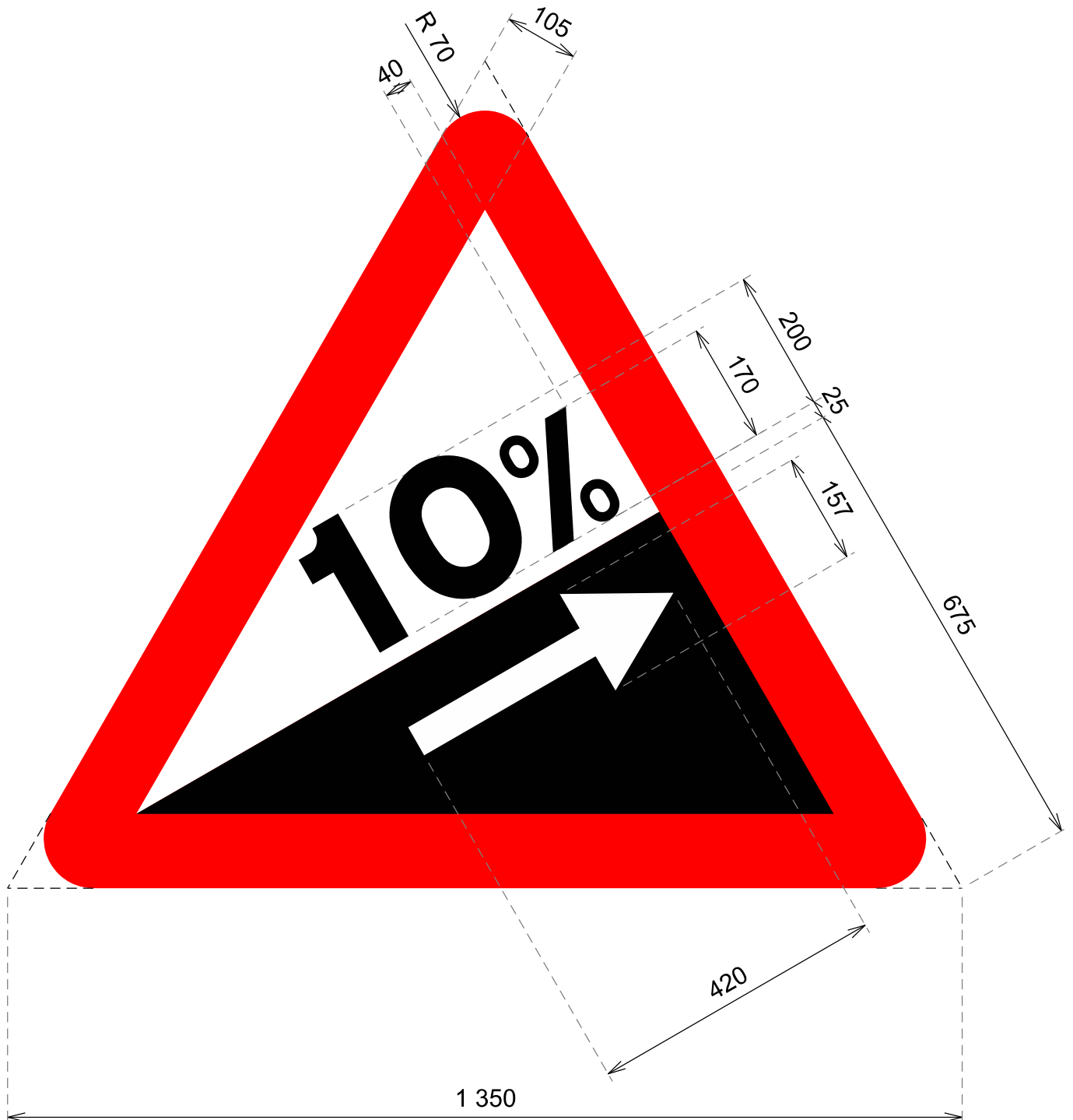

cotas en mm

Subida con fuerte pendiente

**P-16b**

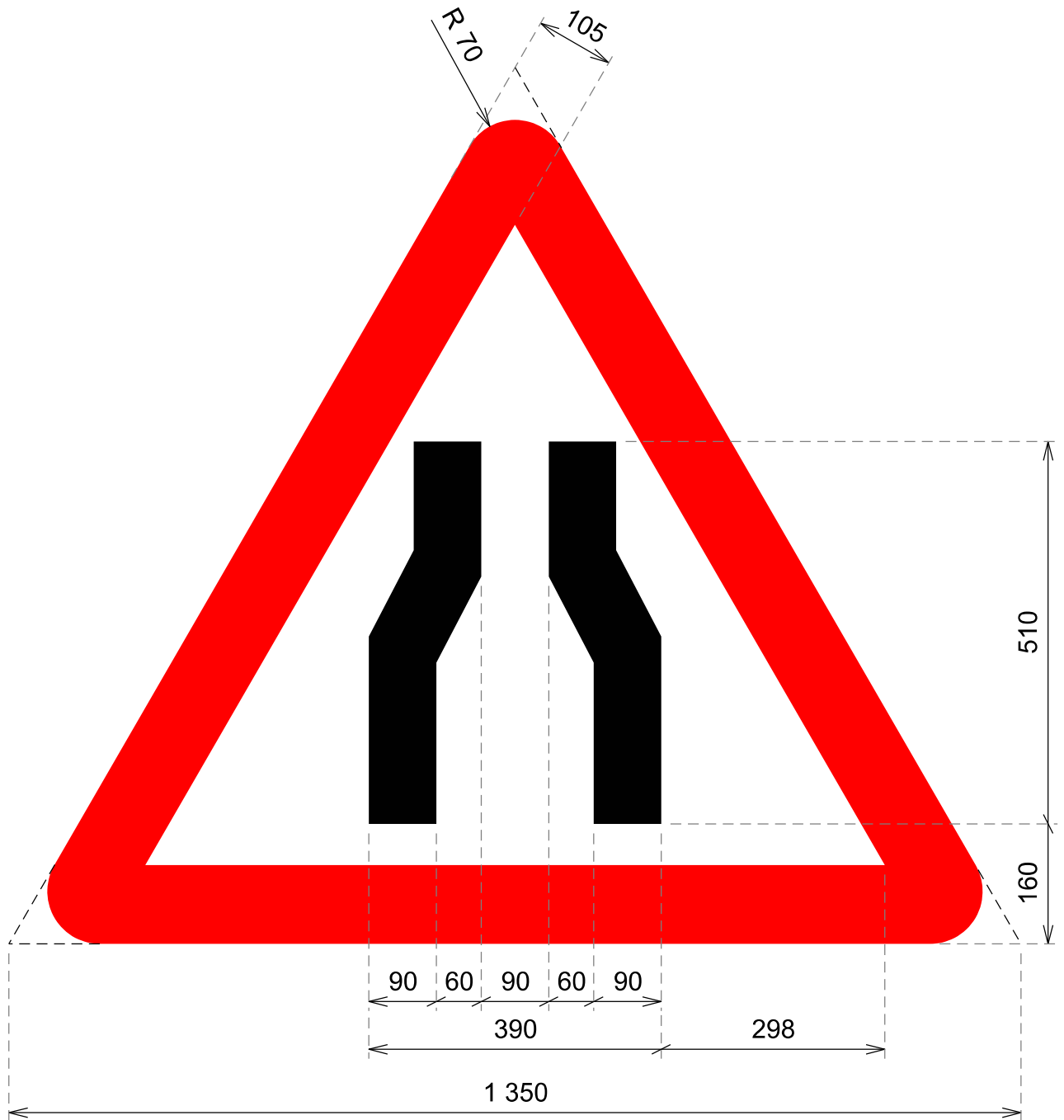

cotas en mm

Estrechamiento de calzada

P-17

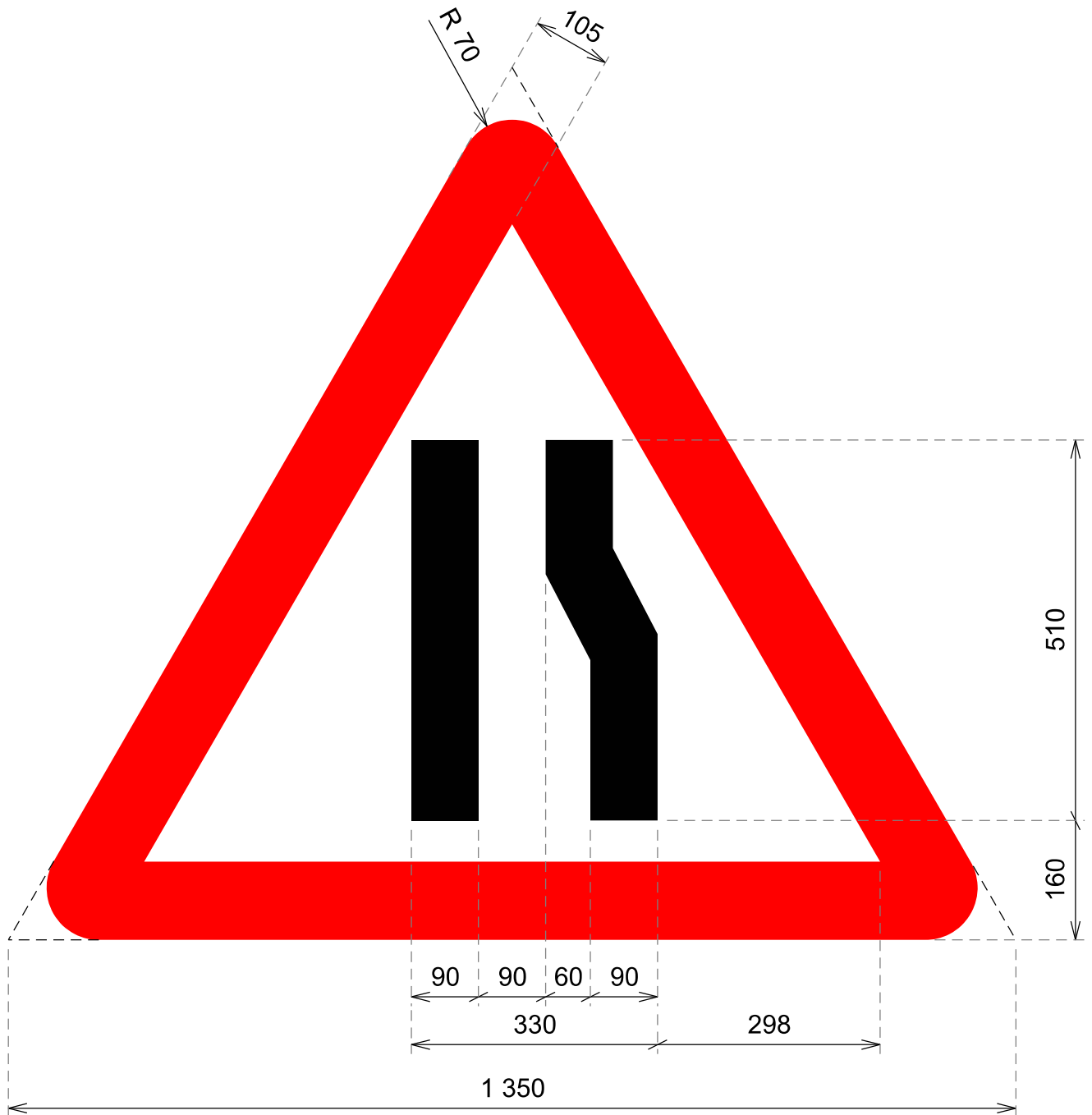

cotas en mm

Estrechamiento de calzada por la derecha

**P-17a**

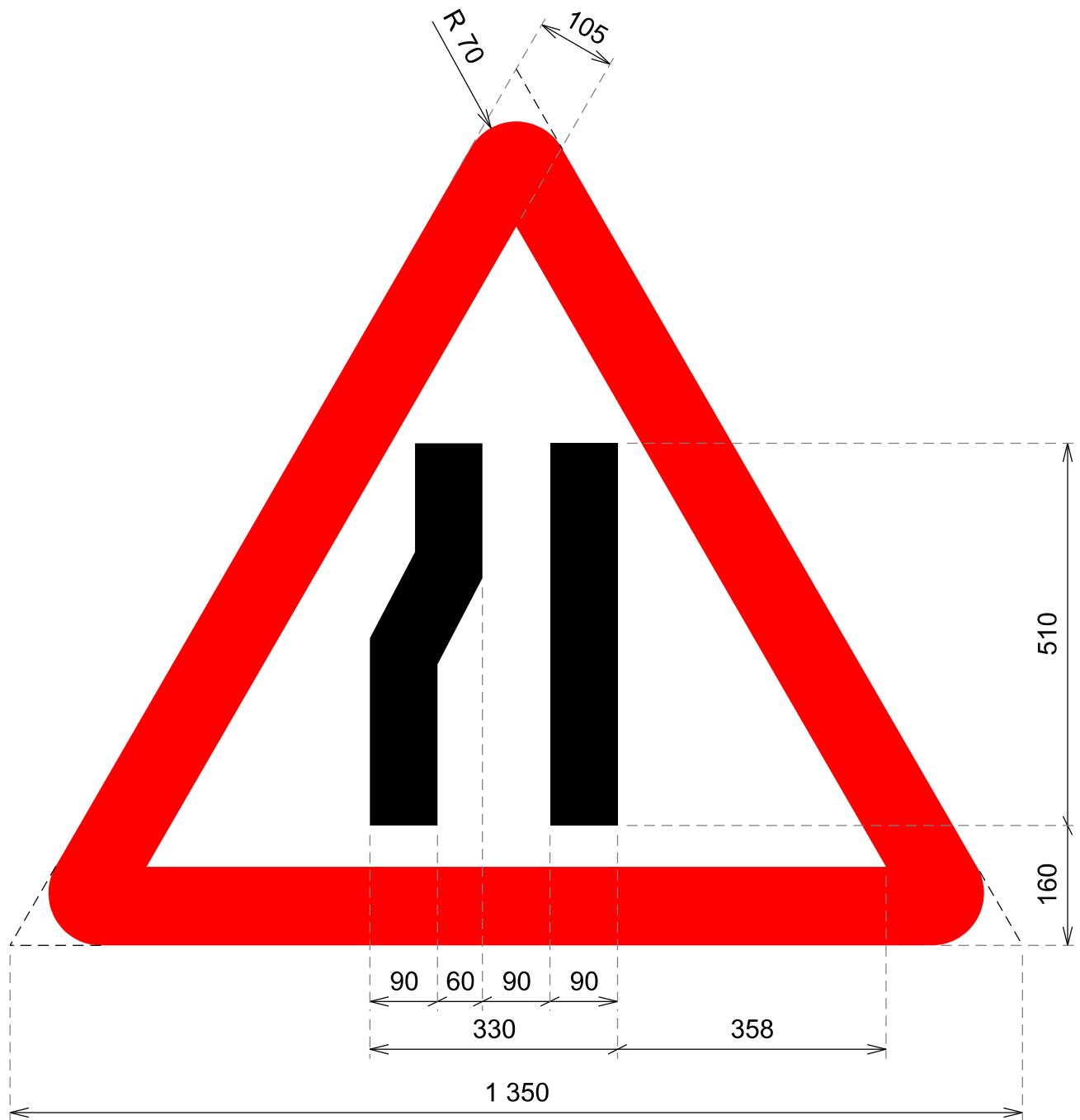

cotas en mm

Estrechamiento de calzada por la izquierda

**P-17b**

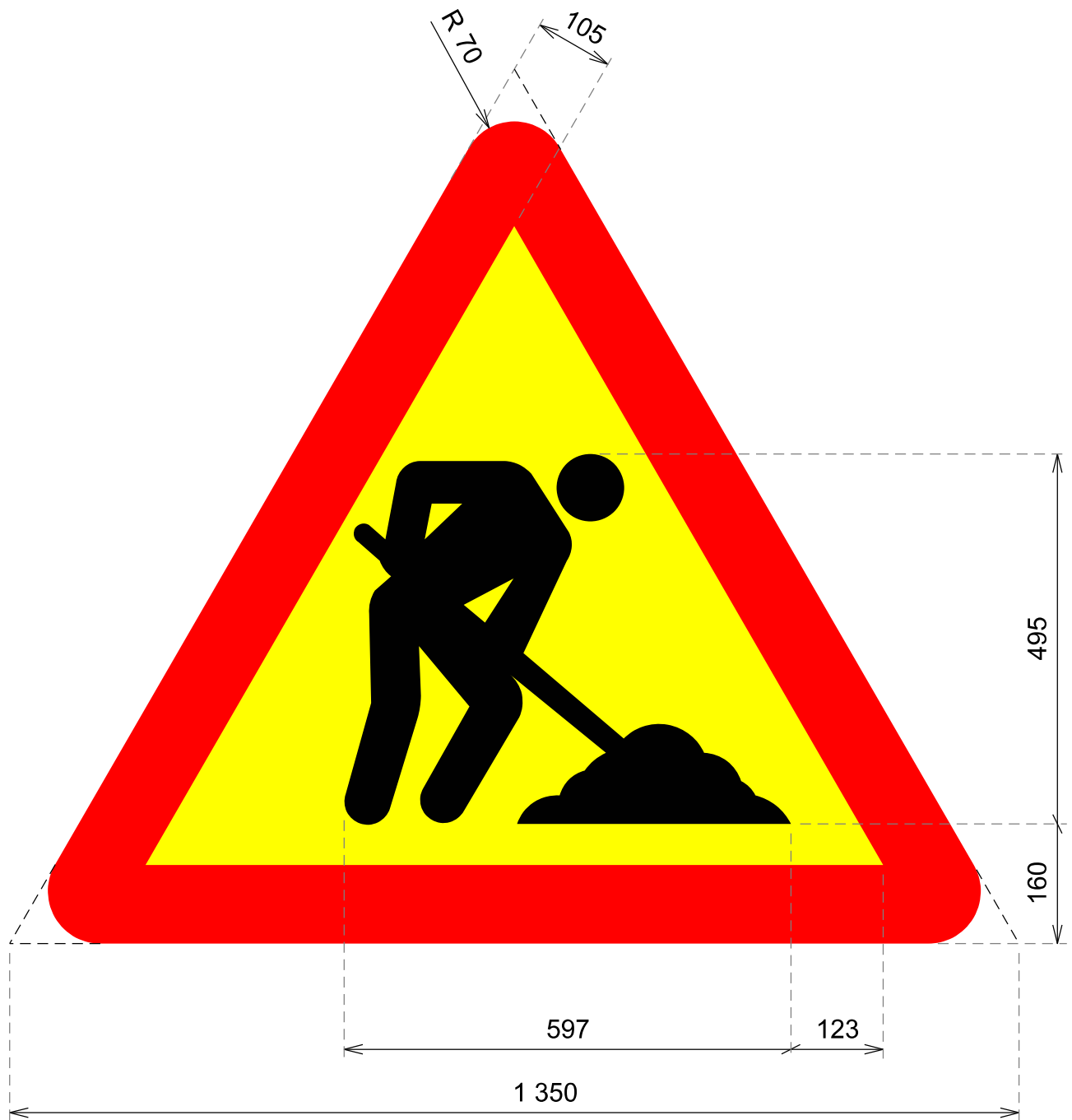

cotas en mm

Obras

**P-18**



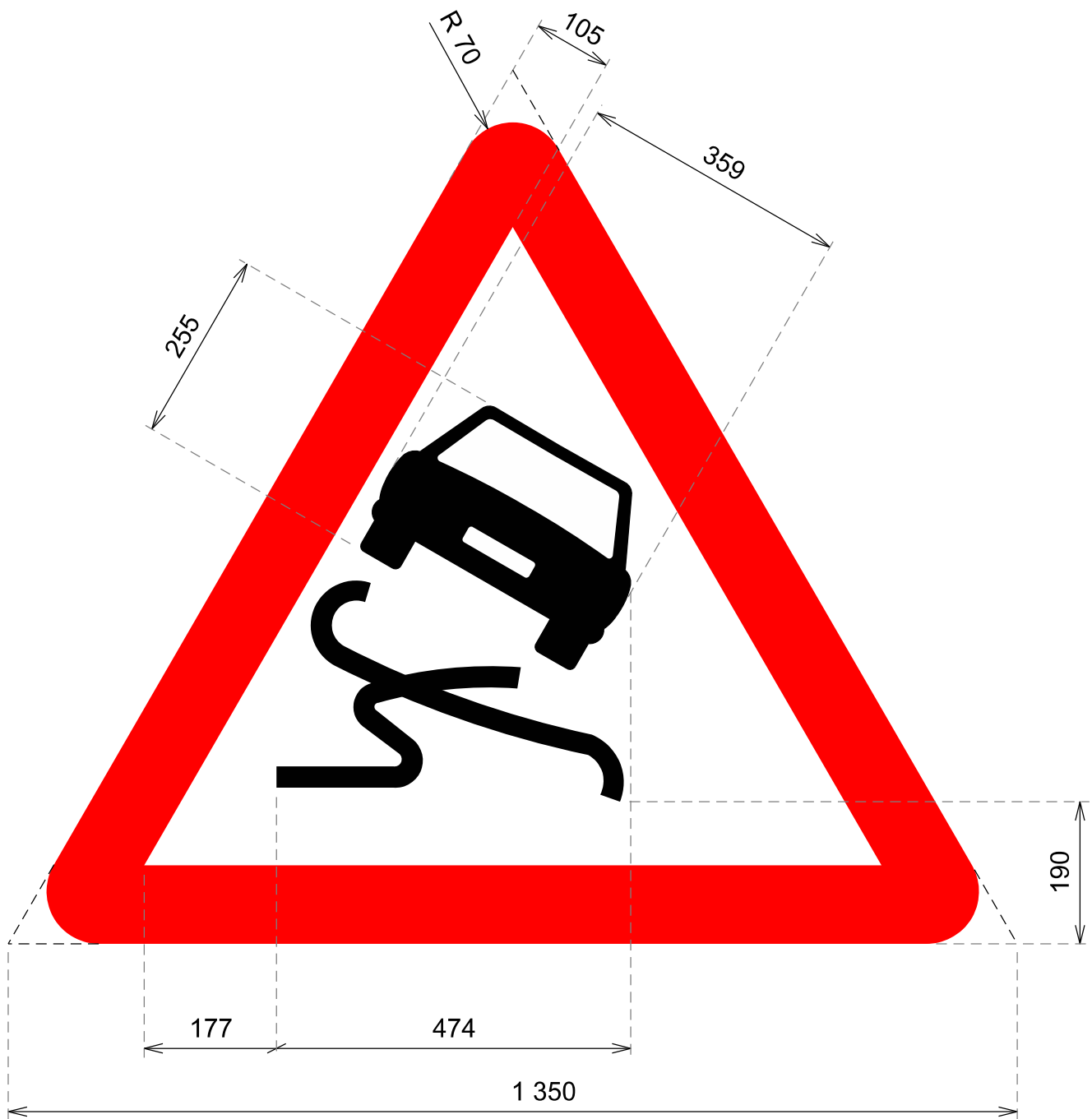

cotas en mm

Pavimento deslizante

P-19

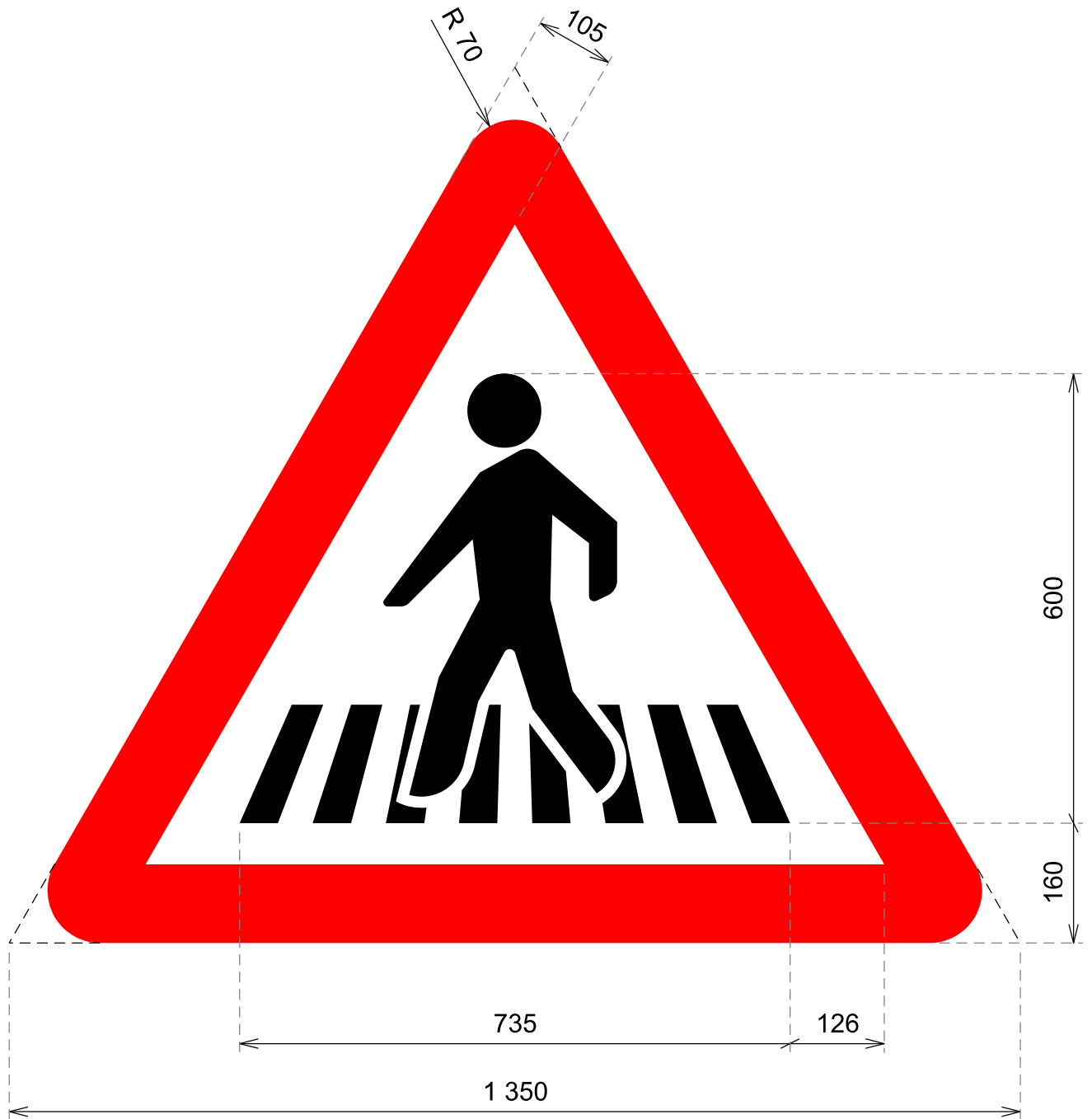

cotas en mm

Paso para peatones

**P-20a**

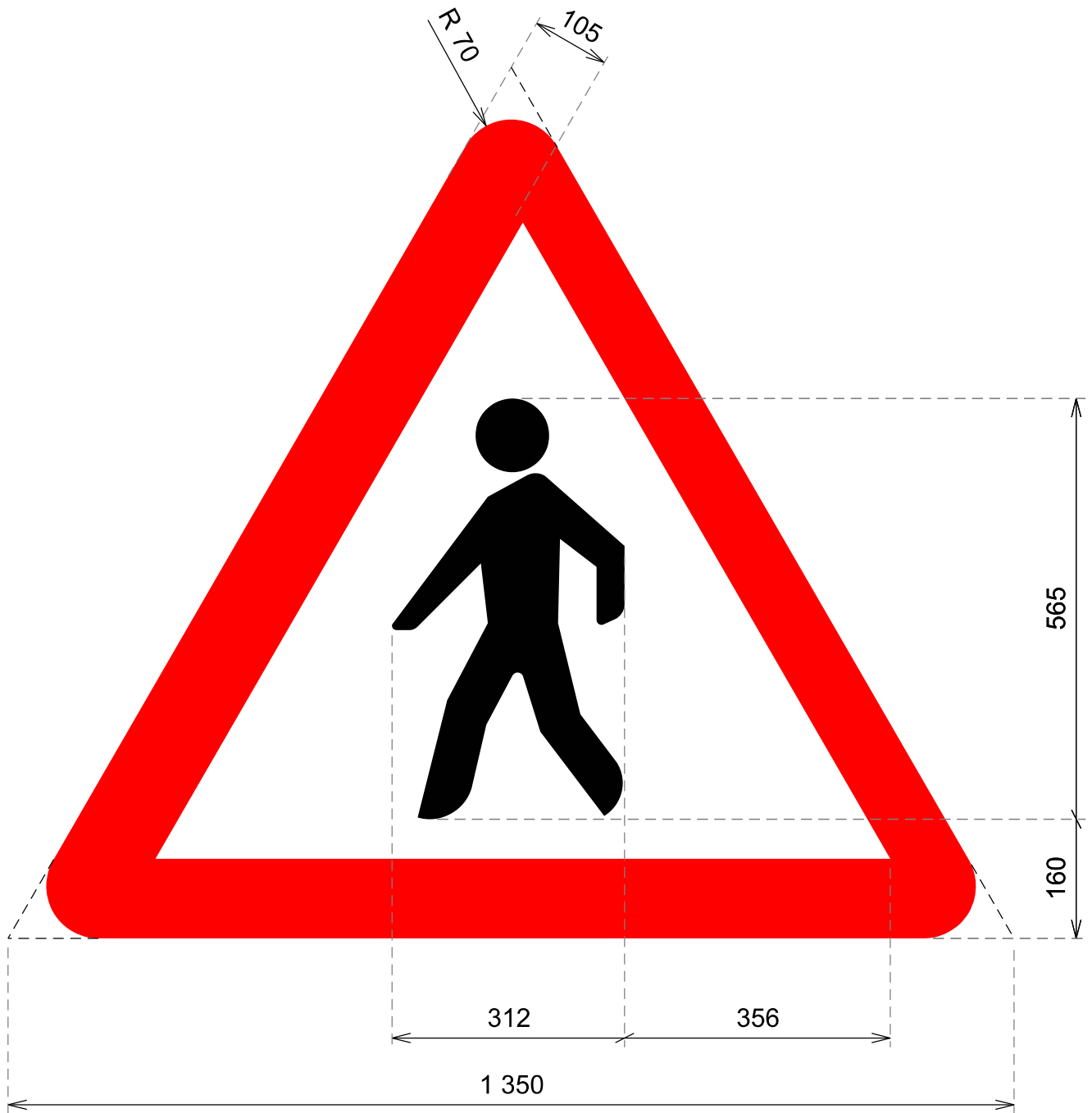

cotas en mm

Peatones

**P-20b**

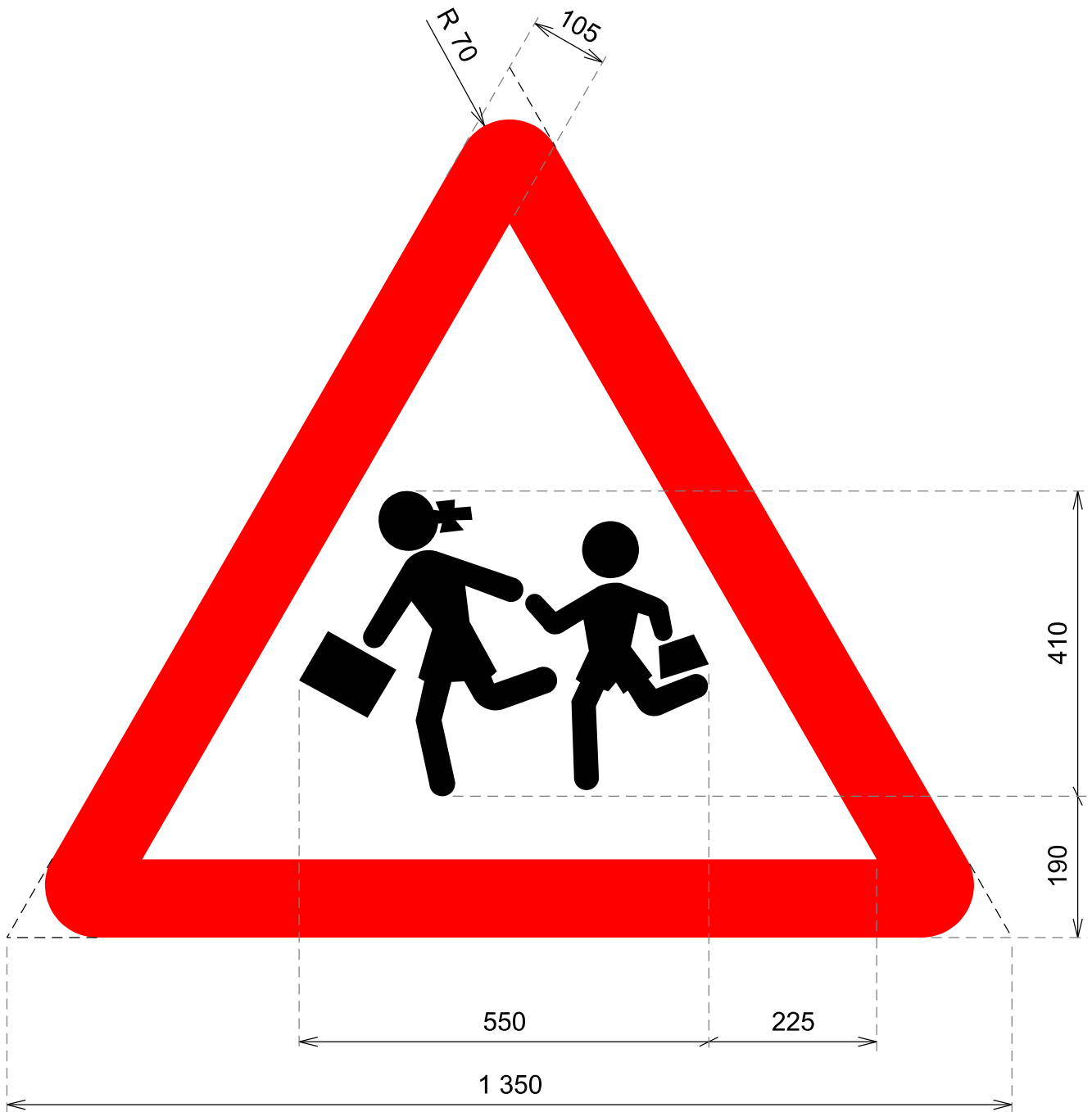

cotas en mm

Niños

P-21a

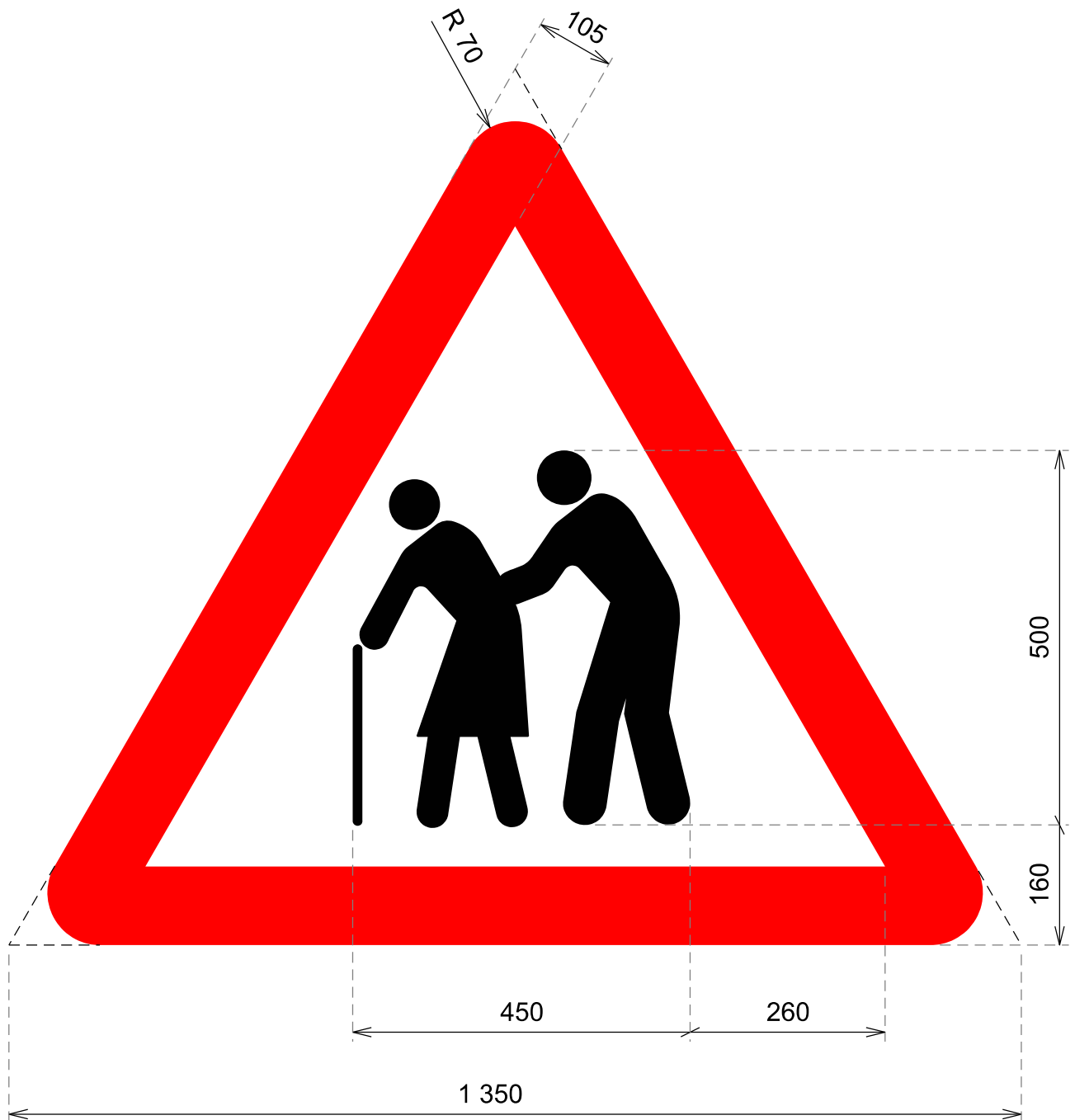

cotas en mm

Ancianos

P-21b



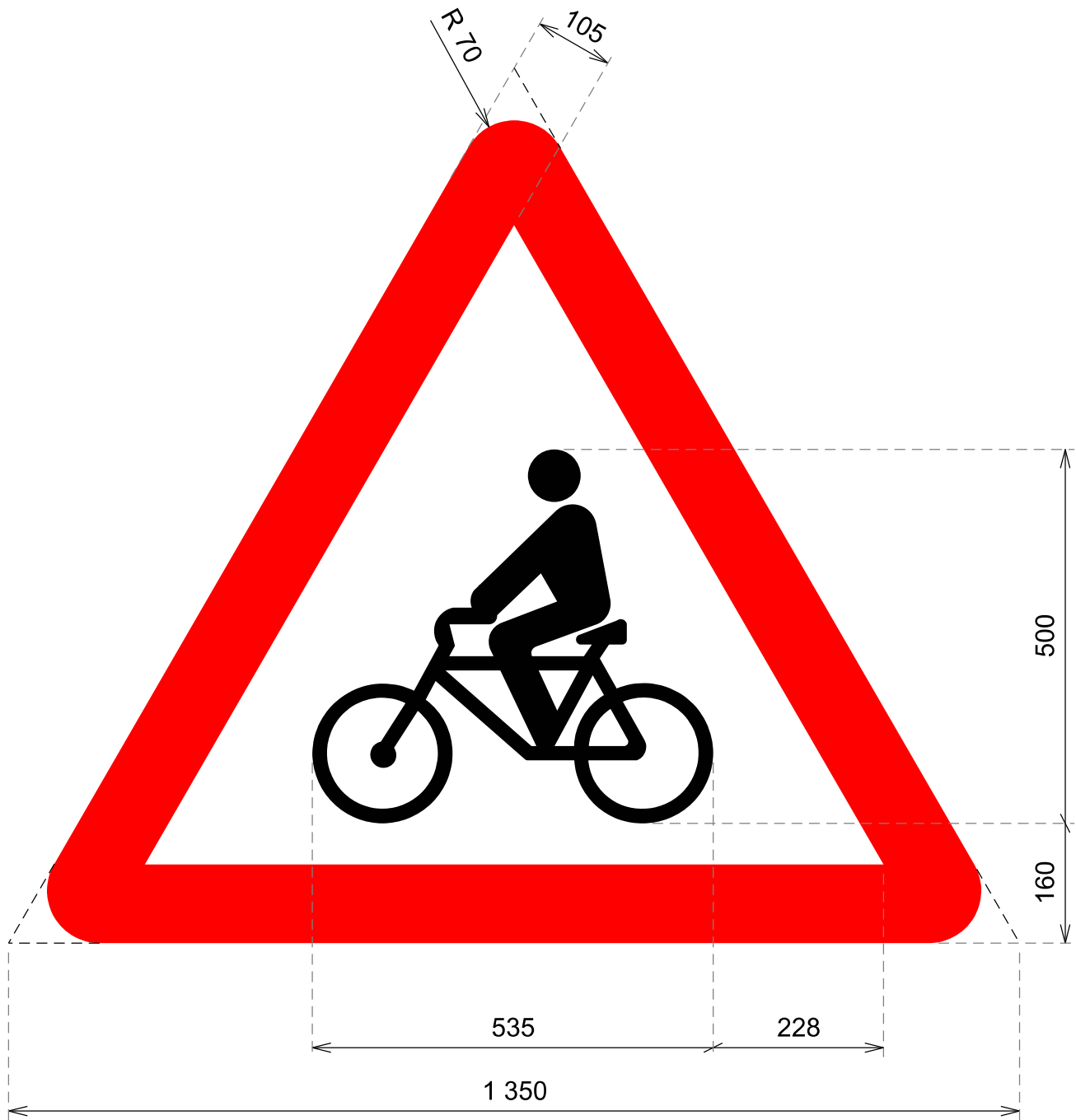

cotas en mm

Ciclistas

P-22b

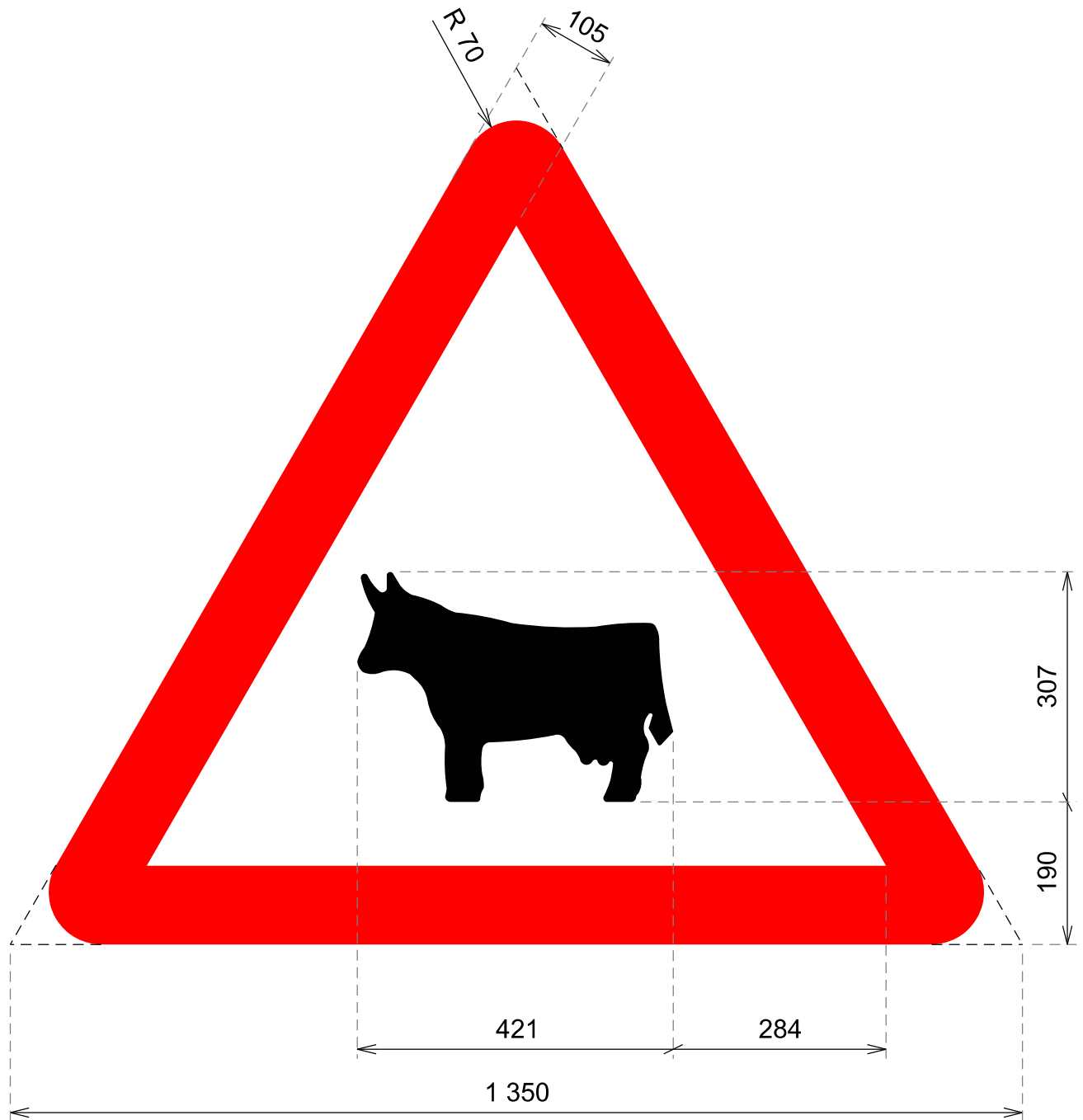

cotas en mm

Paso de animales domésticos o ganado

**P-23**





cotas en mm

## Paso de animales en libertad

## P-24

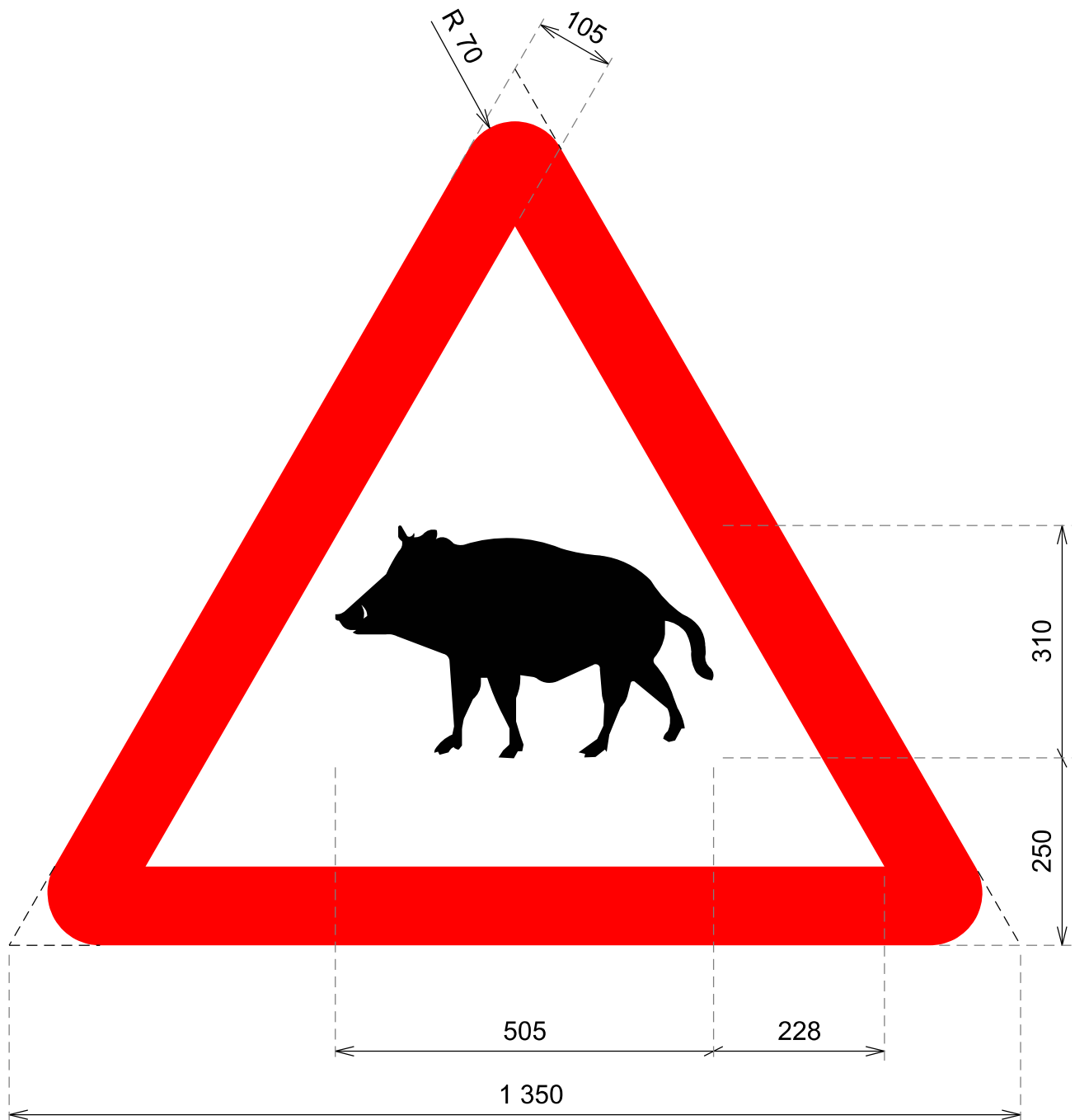

cotas en mm

Paso de animales en libertad (jabalíes)

P-24a

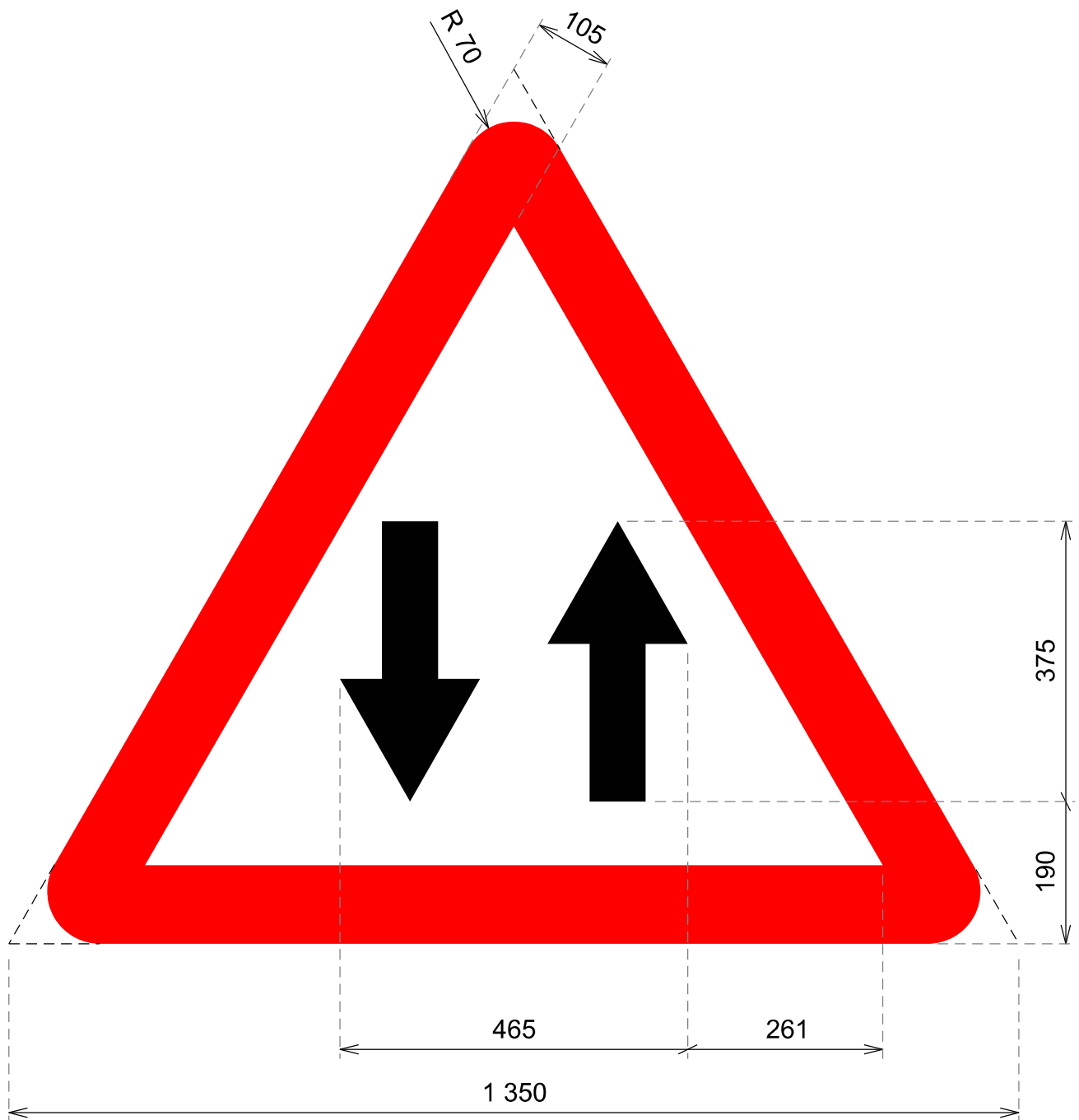

cotas en mm

Circulación en los dos sentidos

**P-25**

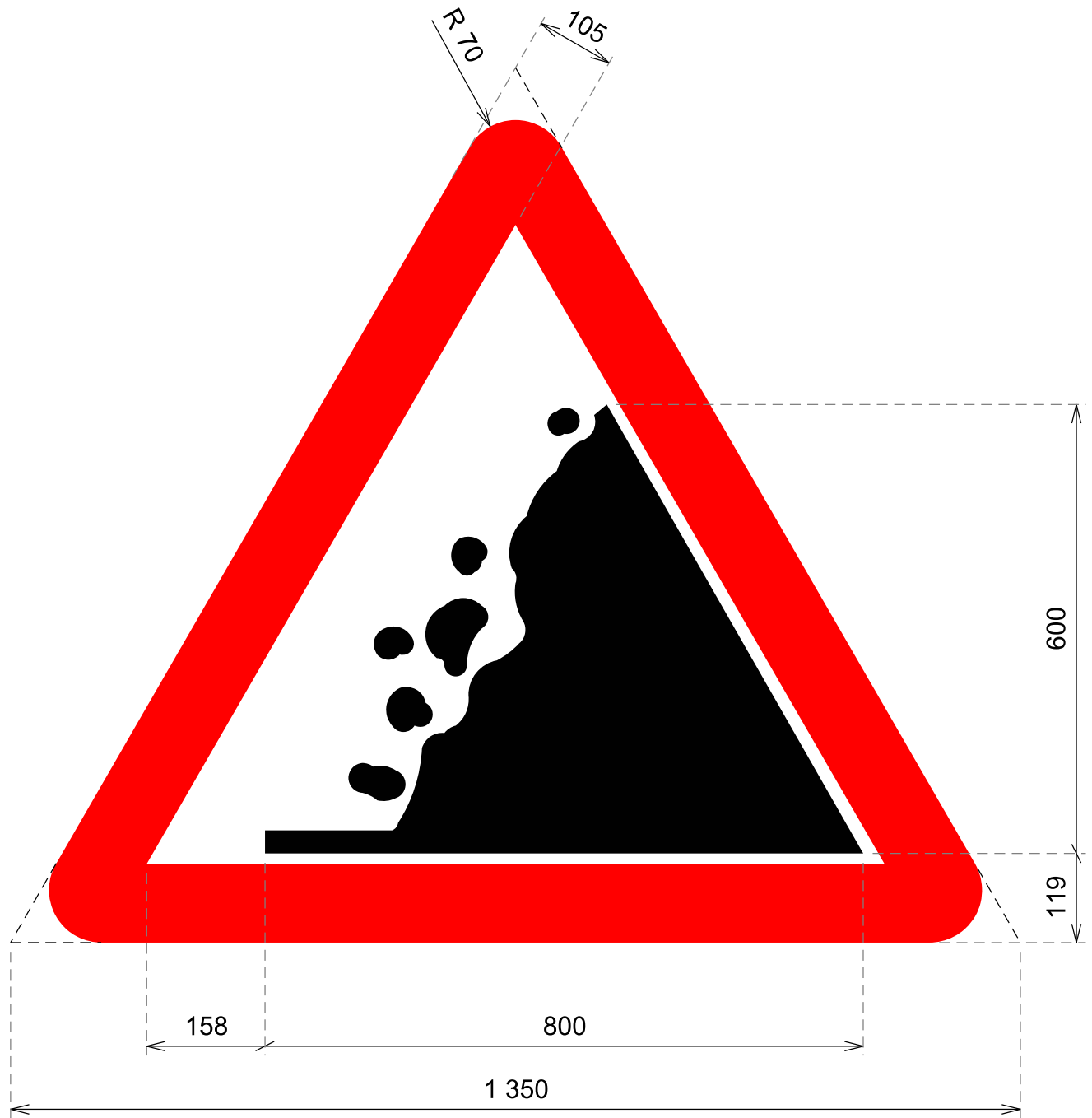

cotas en mm

Desprendimiento

P-26

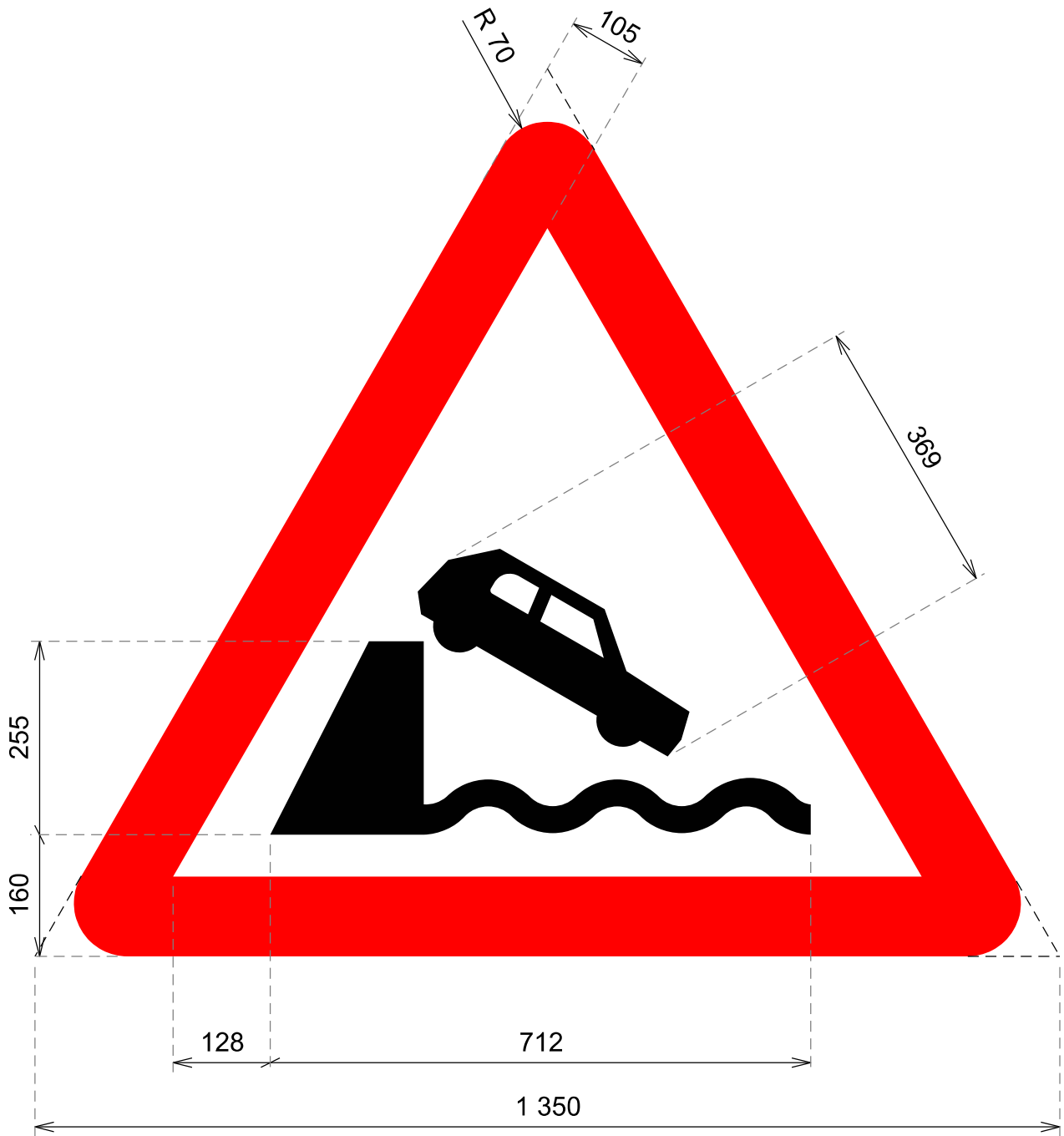

cotas en mm

Muelle

P-27

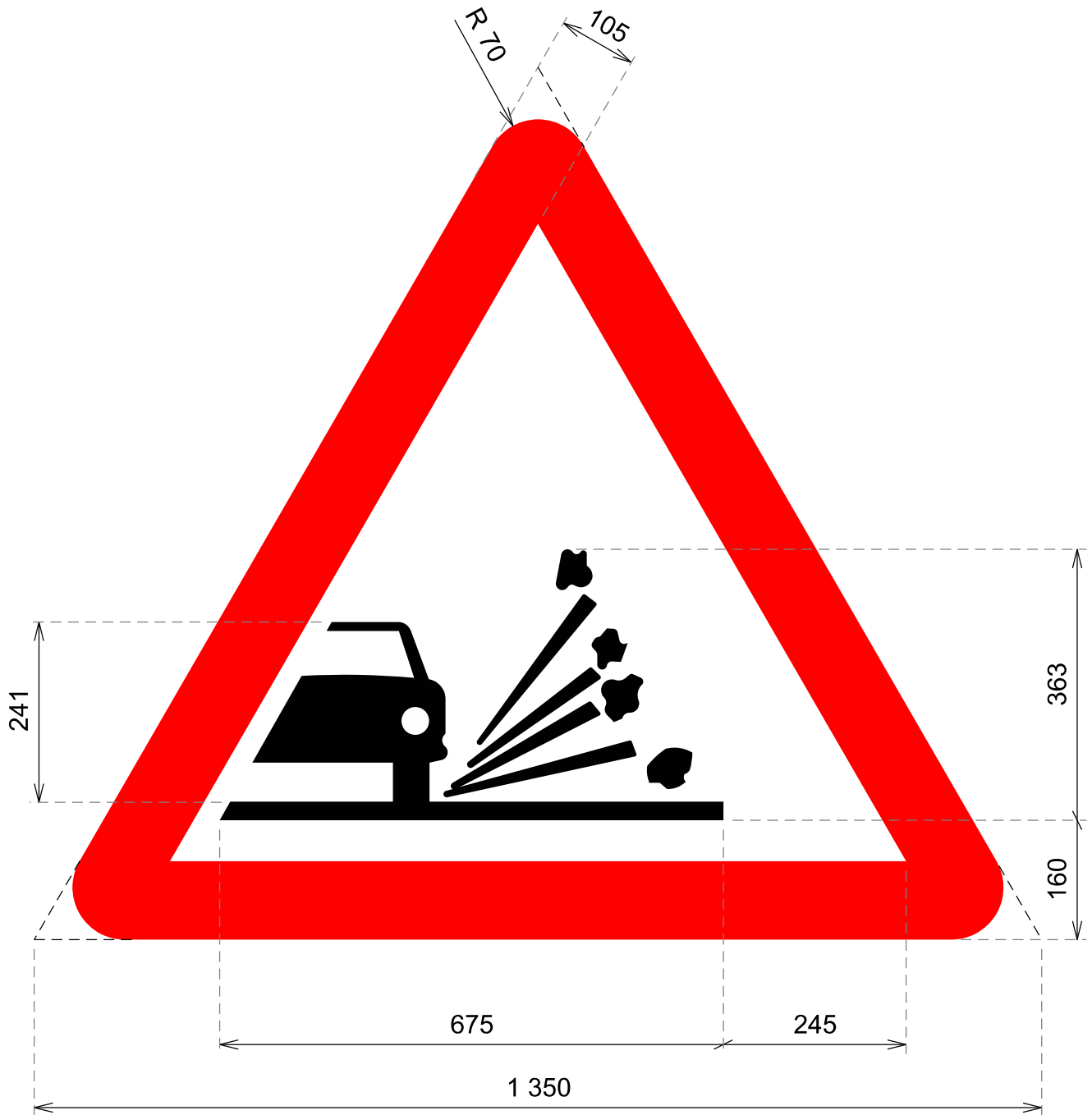

cotas en mm

Proyección de gravilla

P-28

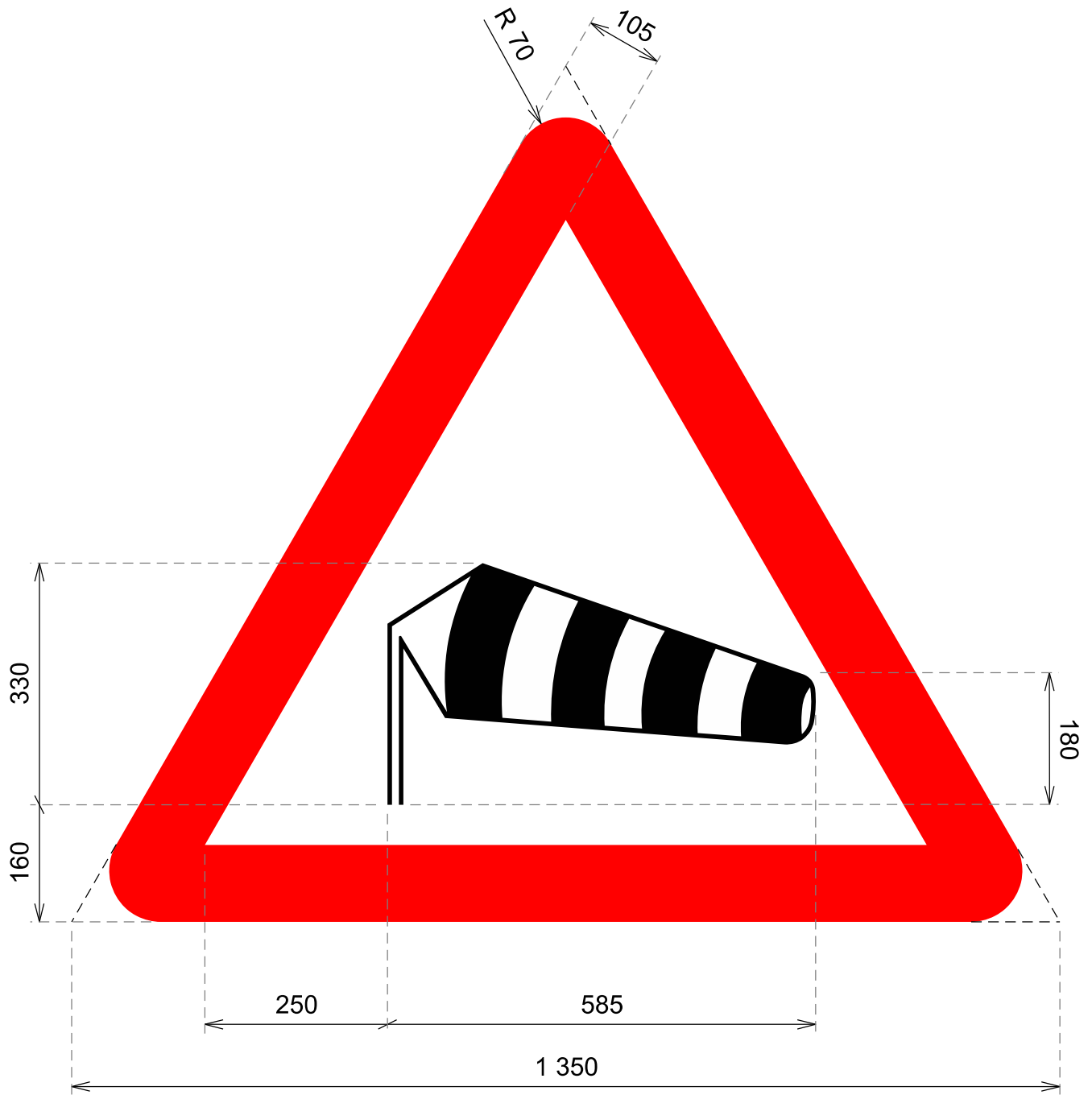

cotas en mm

## Viento transversal

## P-29

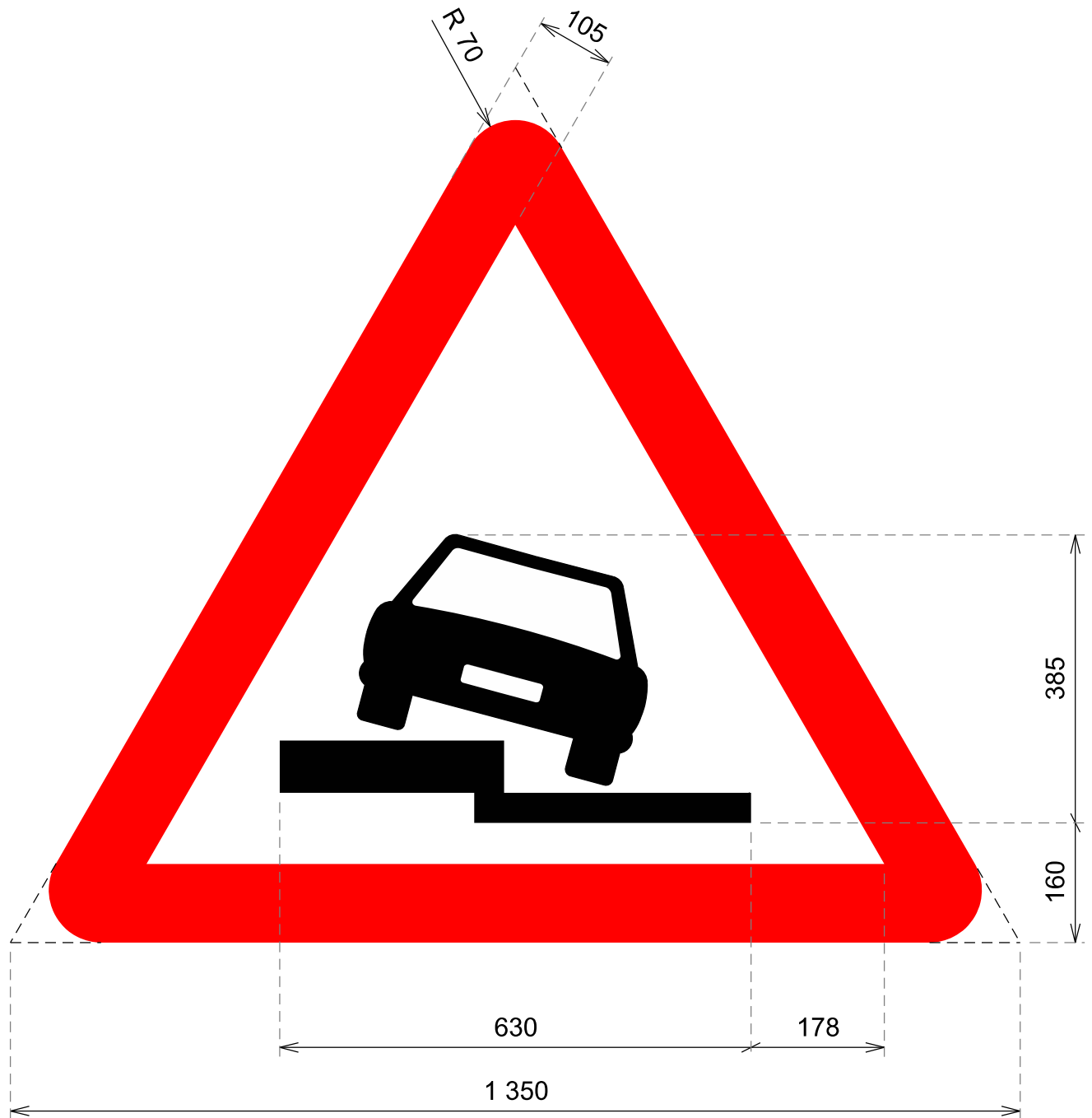

cotas en mm

Escalón lateral

**P-30**



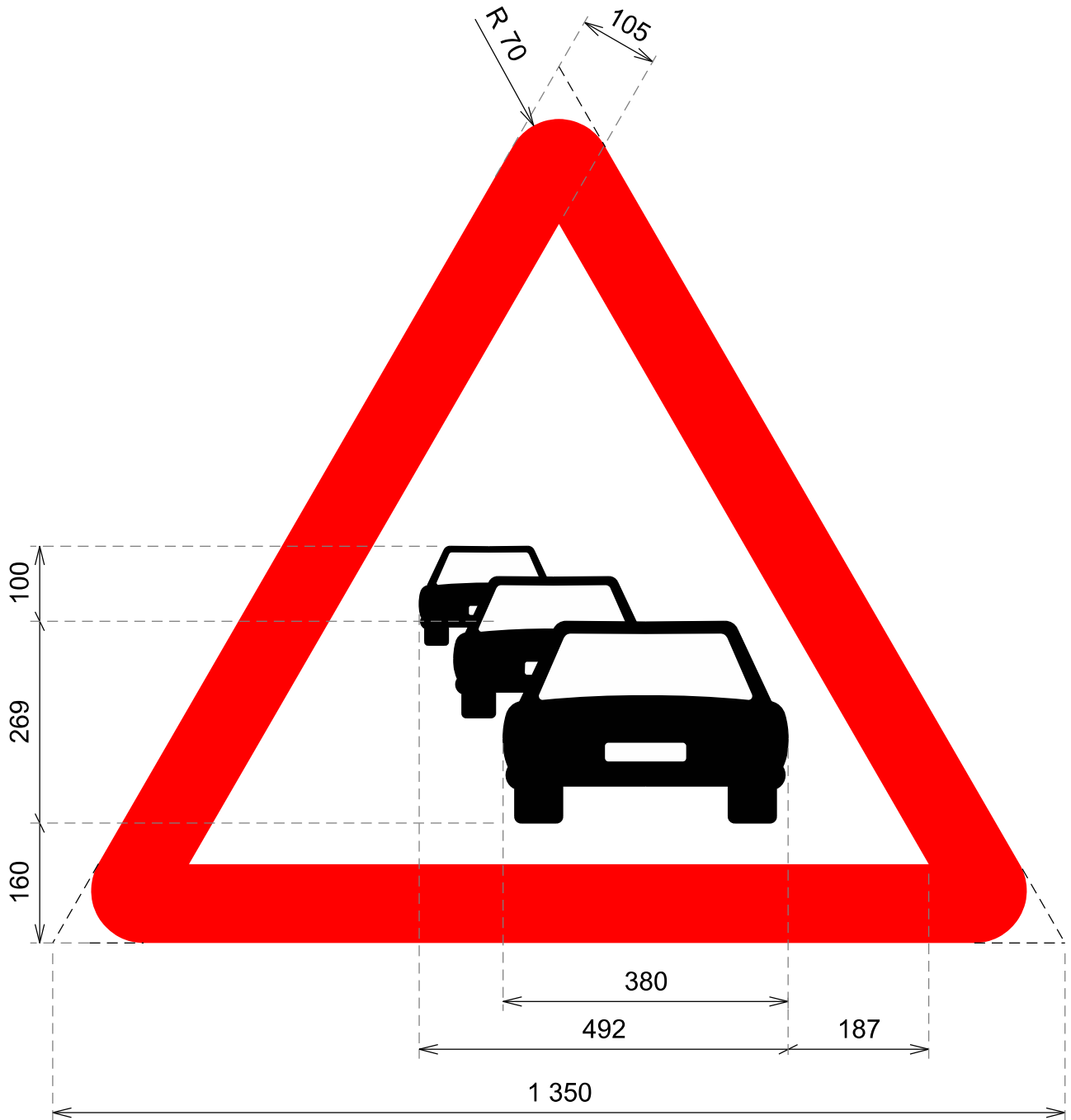

cotas en mm

## Congestión

## P-31

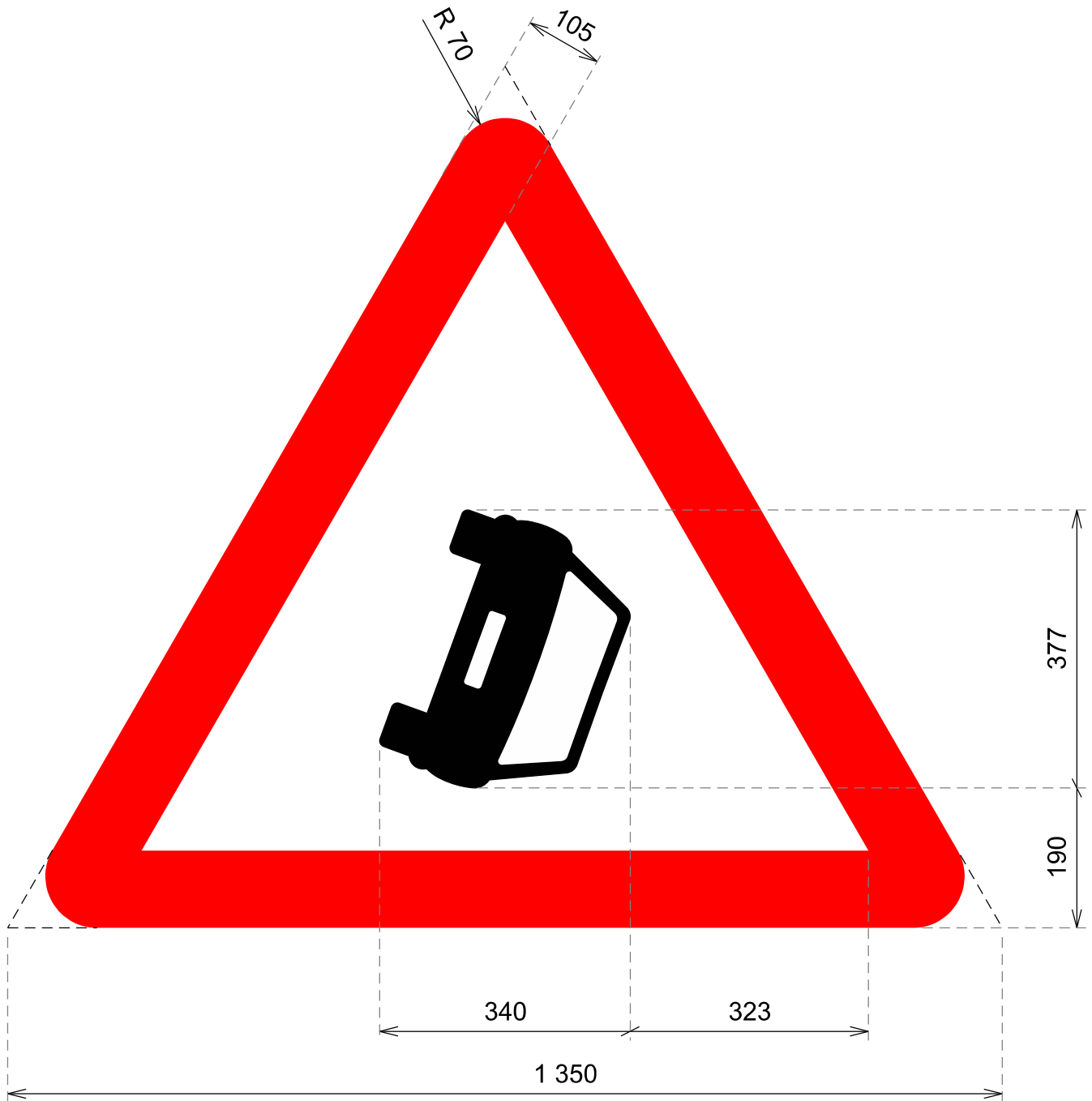

cotas en mm

Obstrucción en la calzada

**P-32**

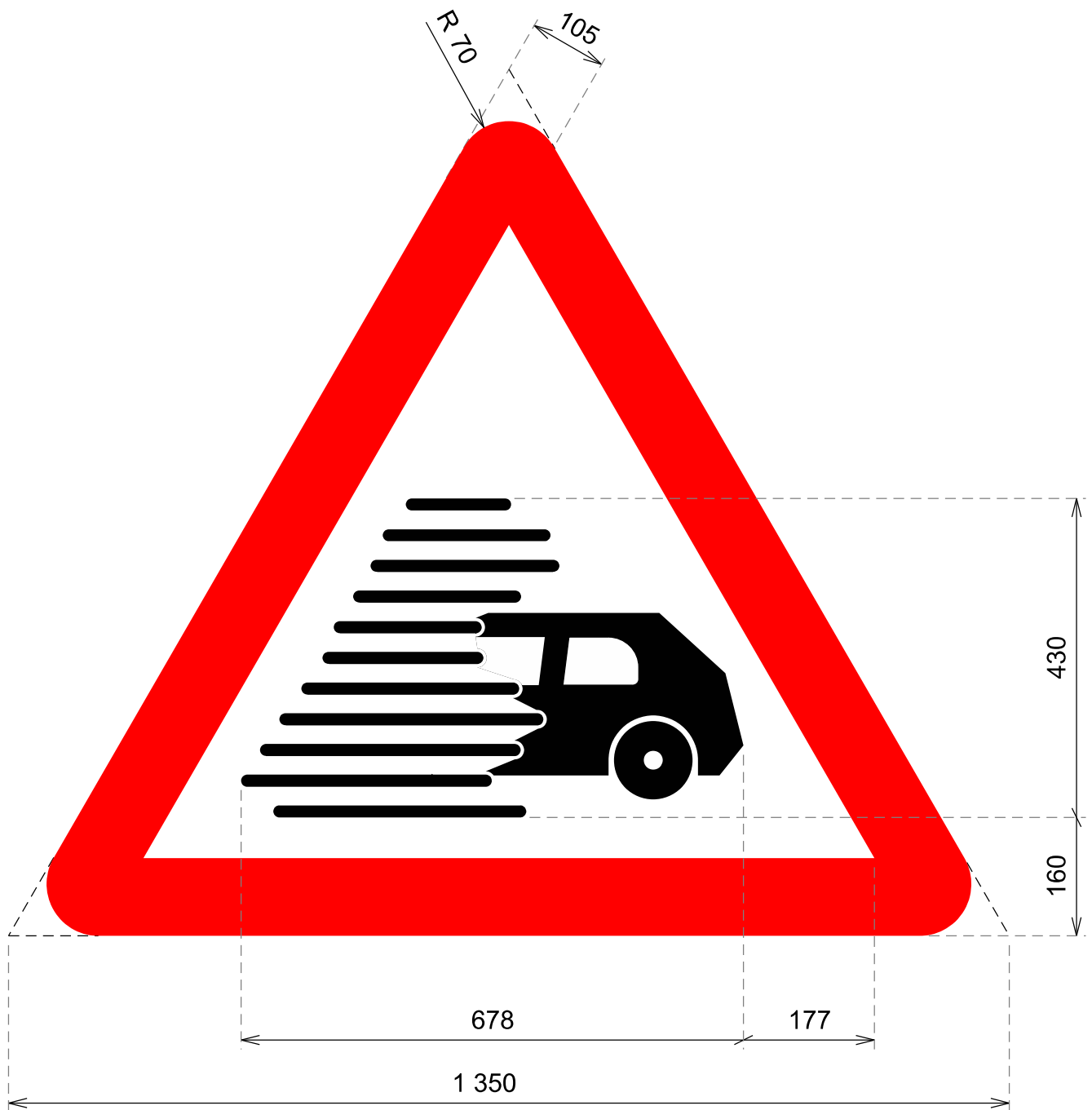

cotas en mm

Visibilidad reducida

**P-33**

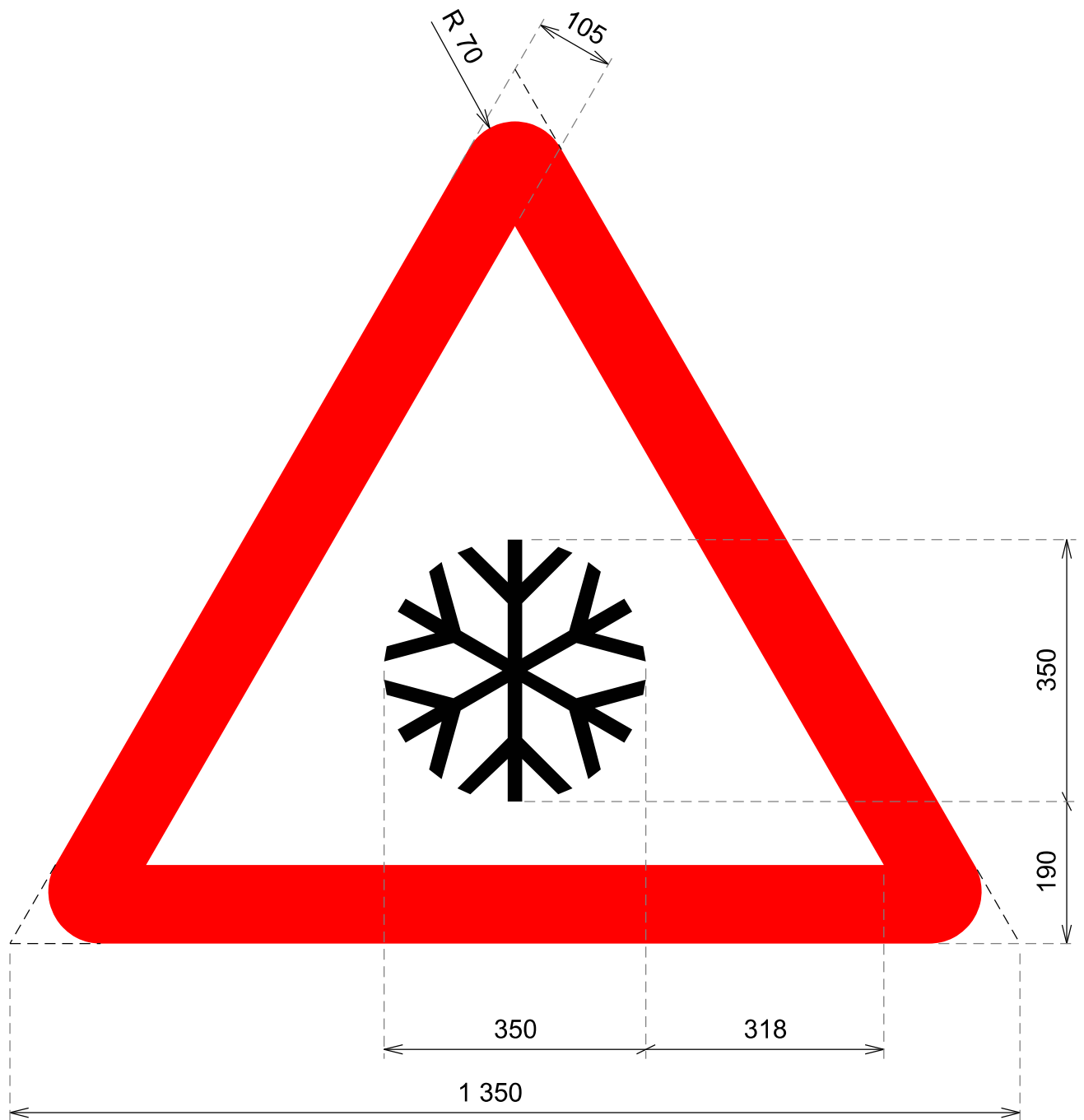

cotas en mm

Presencia de hielo o nieve

**P-34**

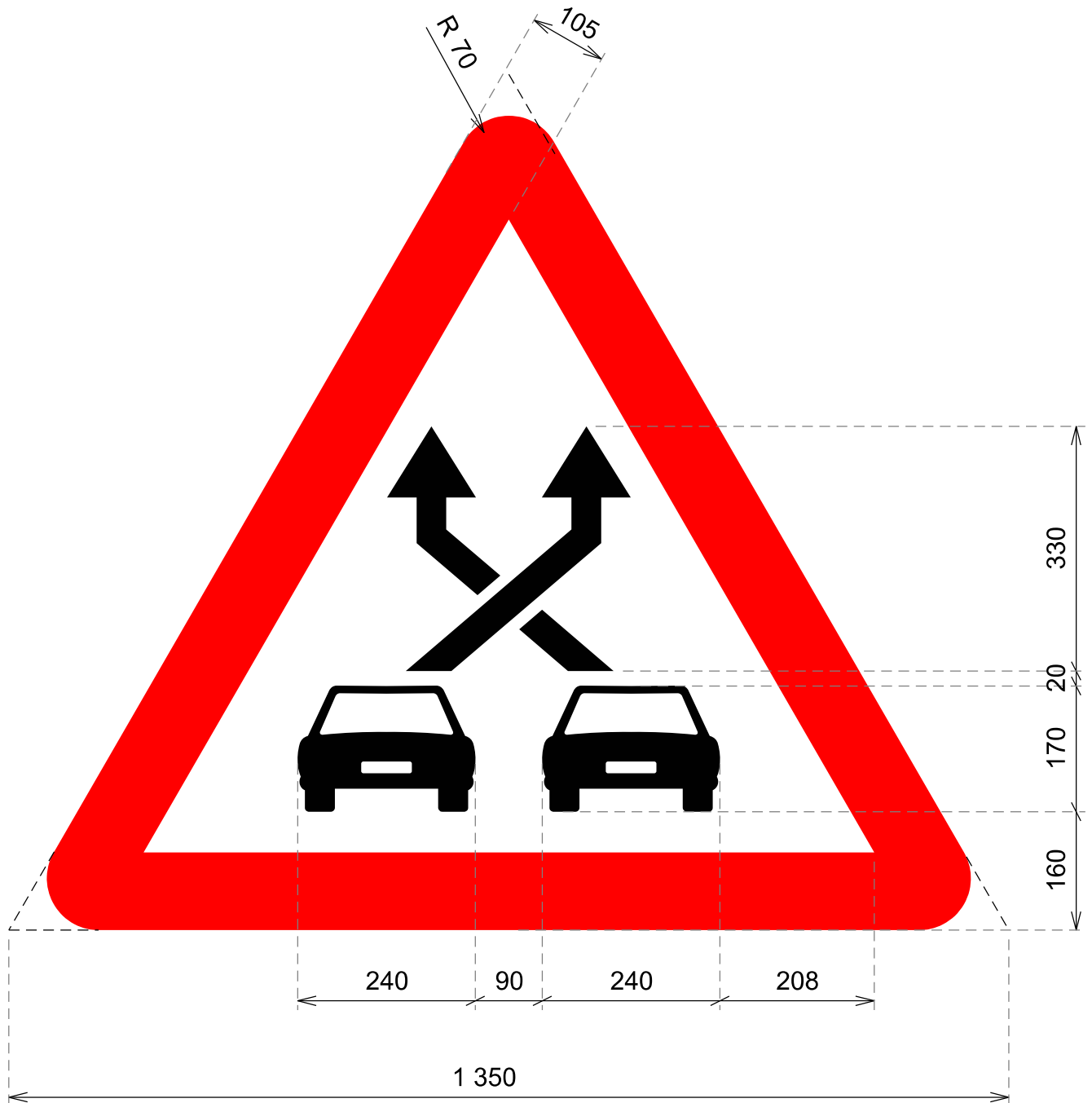

cotas en mm

Trenzado

**P-35**

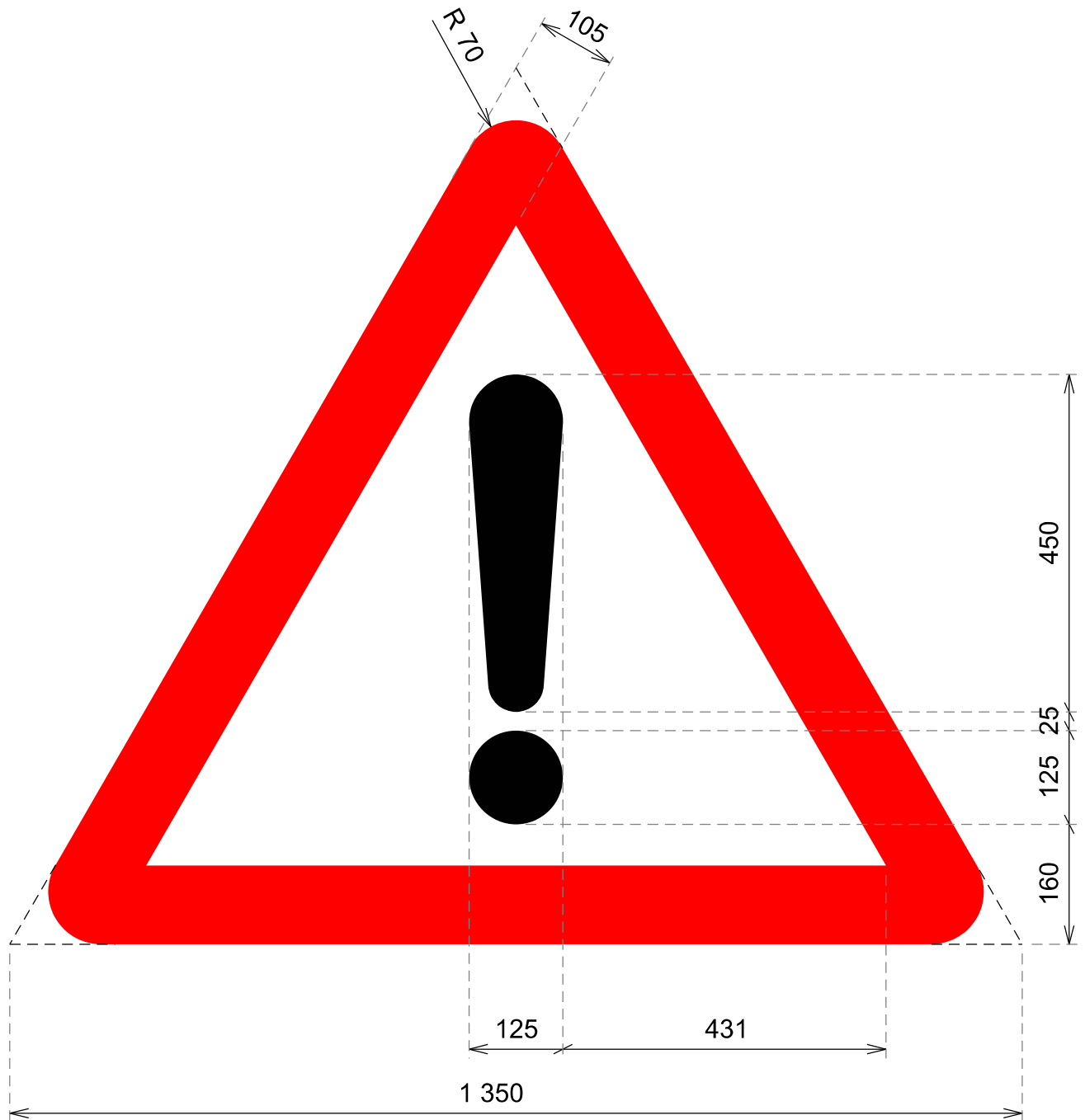

cotas en mm

Otros peligros

**P-50**

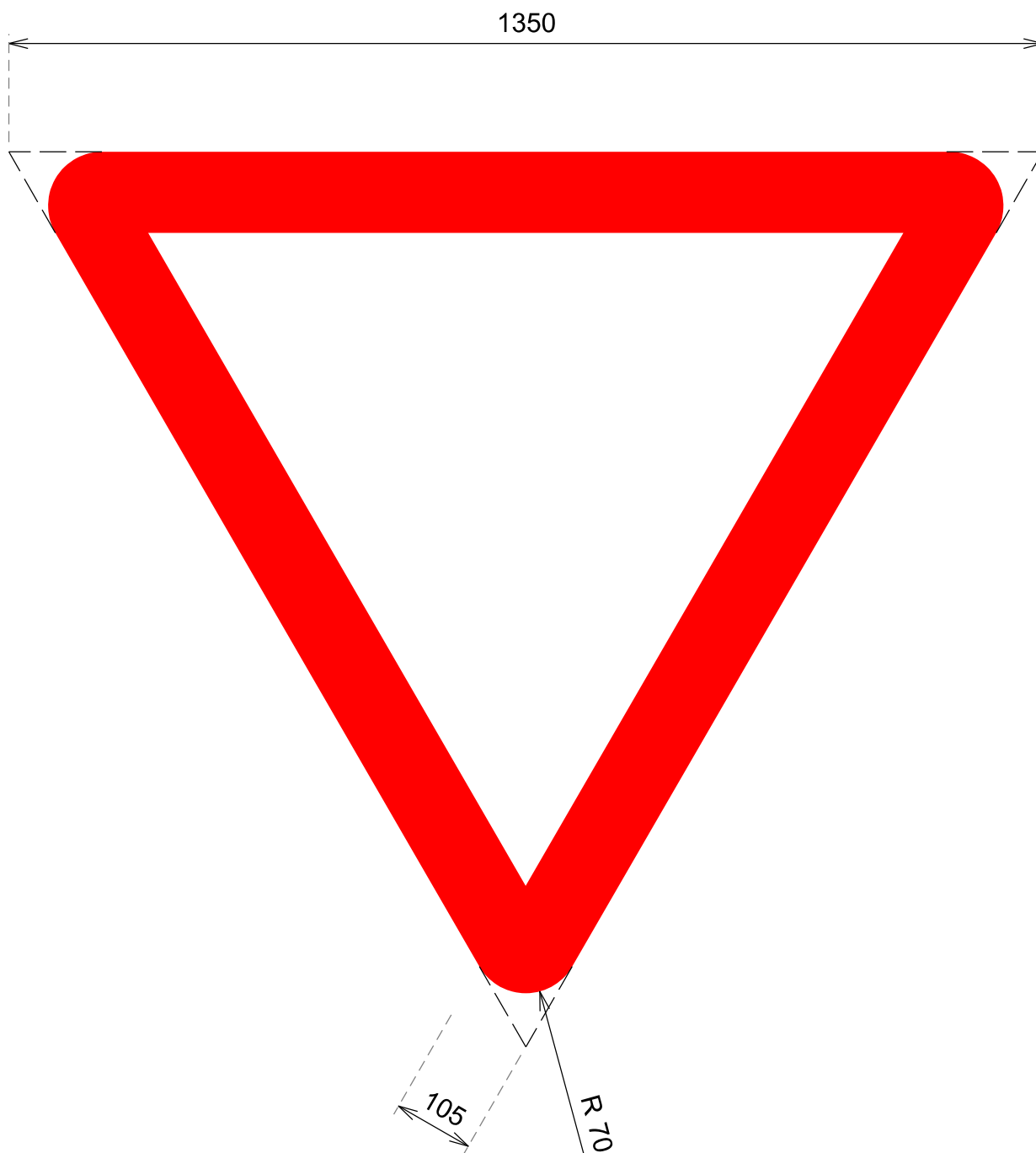

cotas en mm

Ceda el paso

R-1

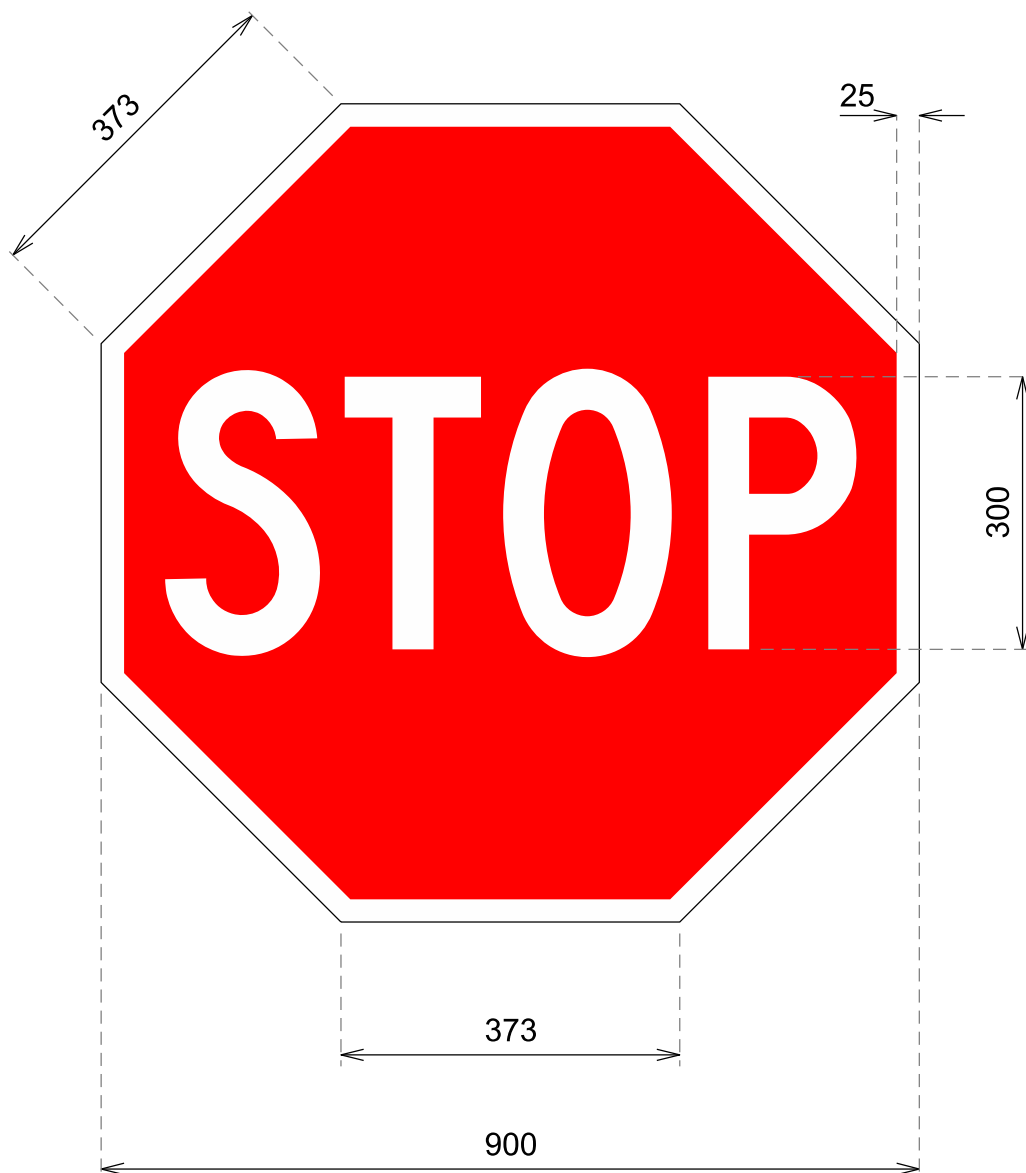

cotas en mm

Detención obligatoria o stop

R-2



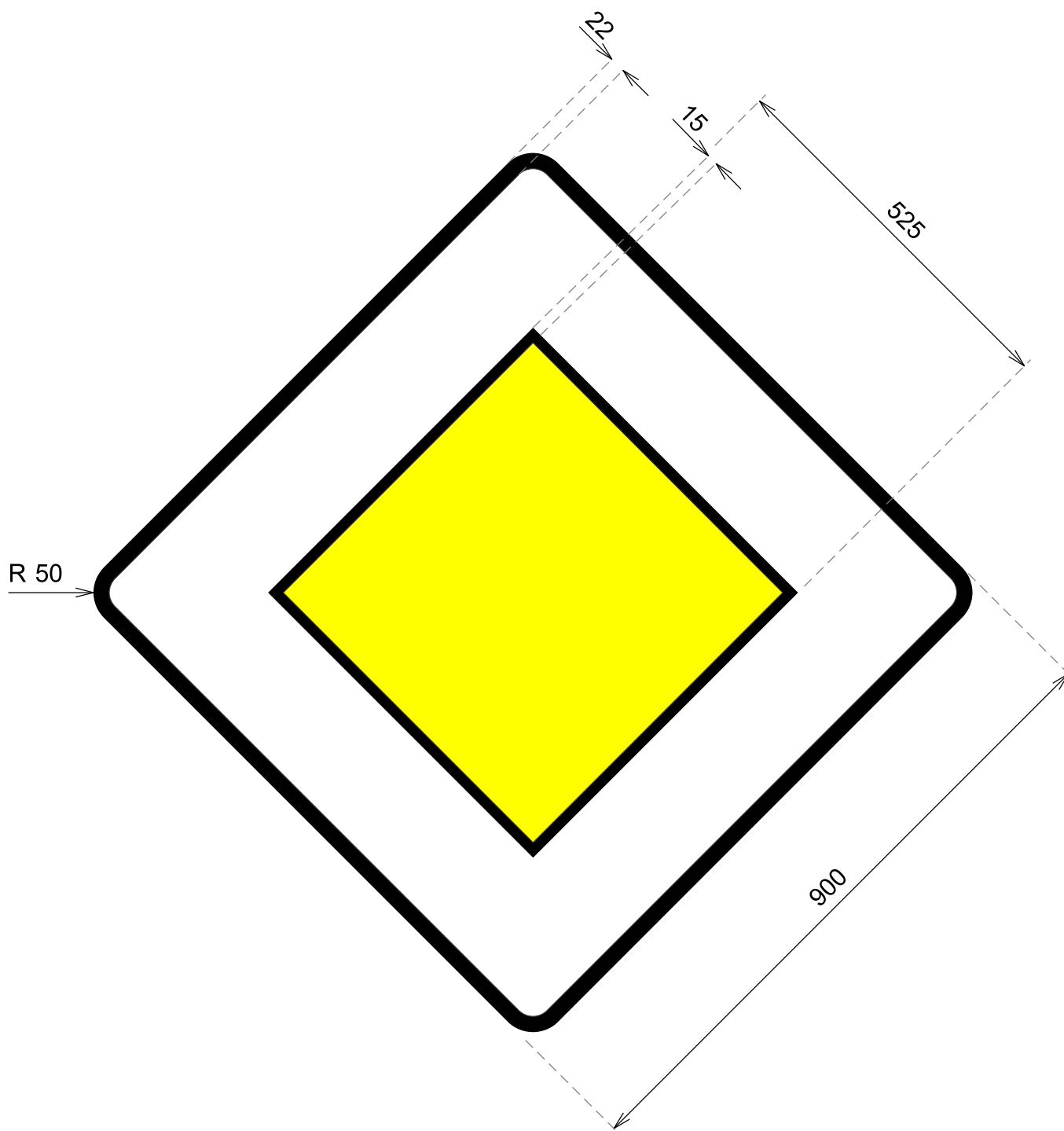

cotas en mm

Calzada con prioridad

R-3

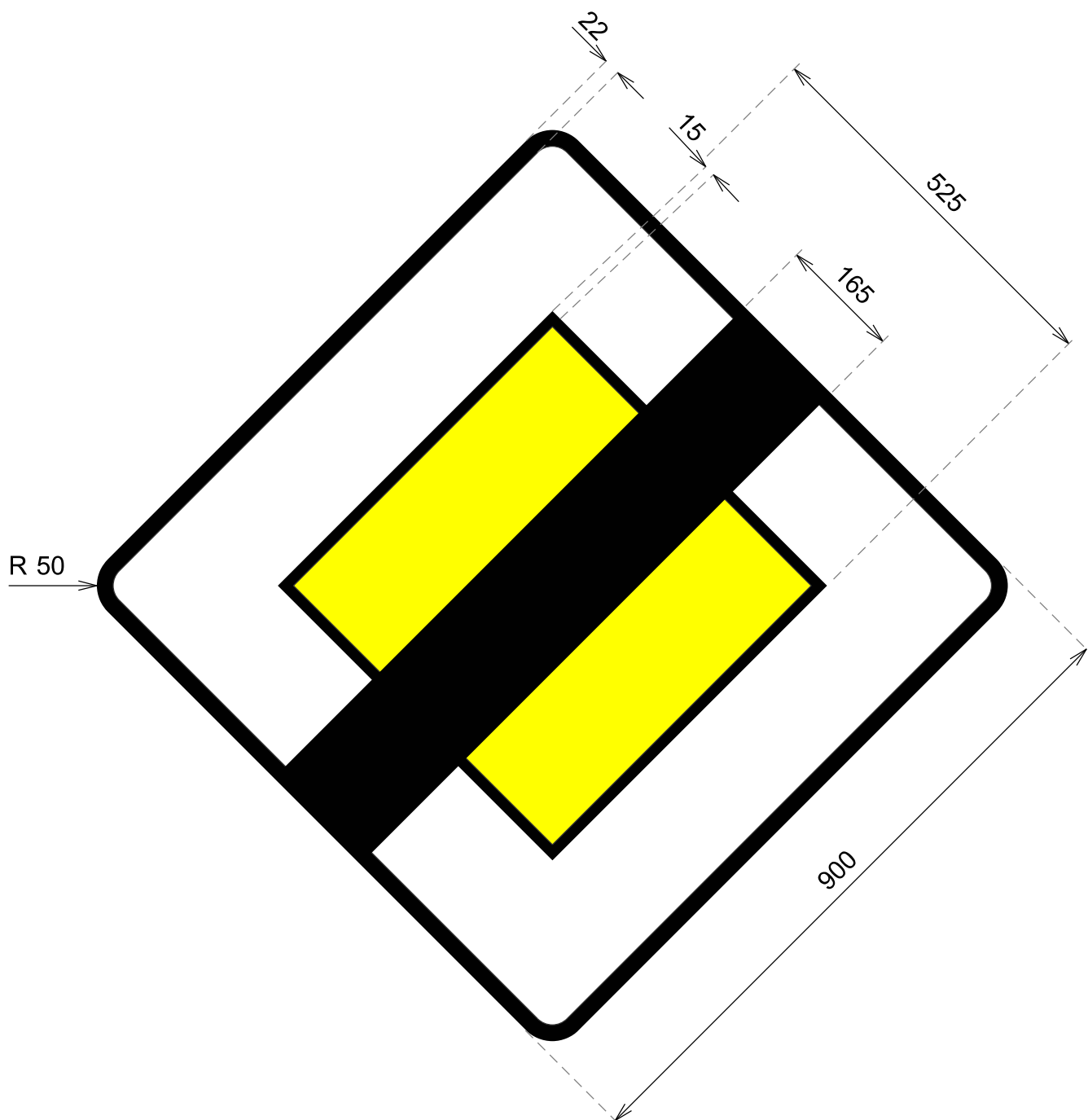

cotas en mm

Fin de prioridad

R-4

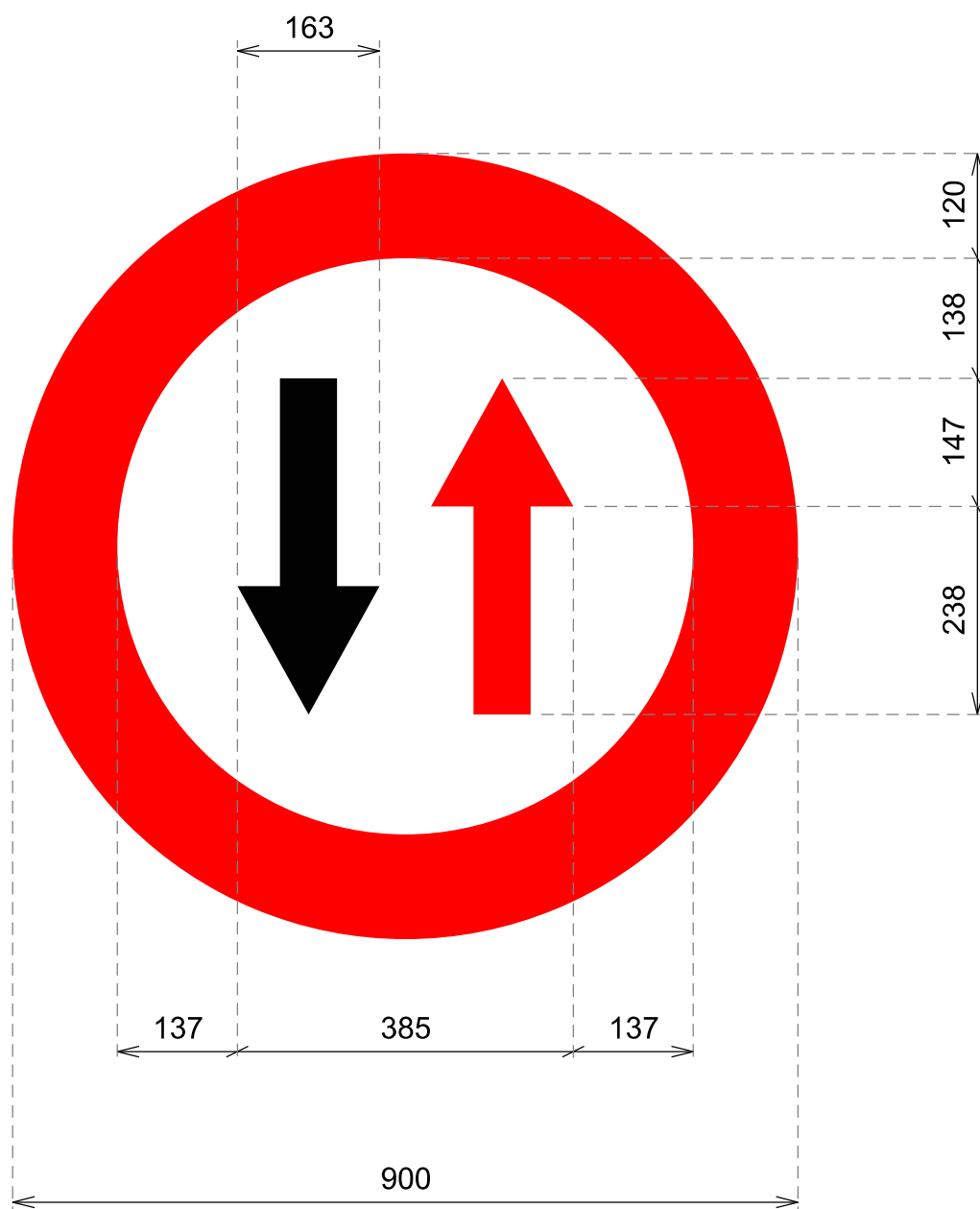

cotas en mm

Prioridad del sentido contrario

R-5

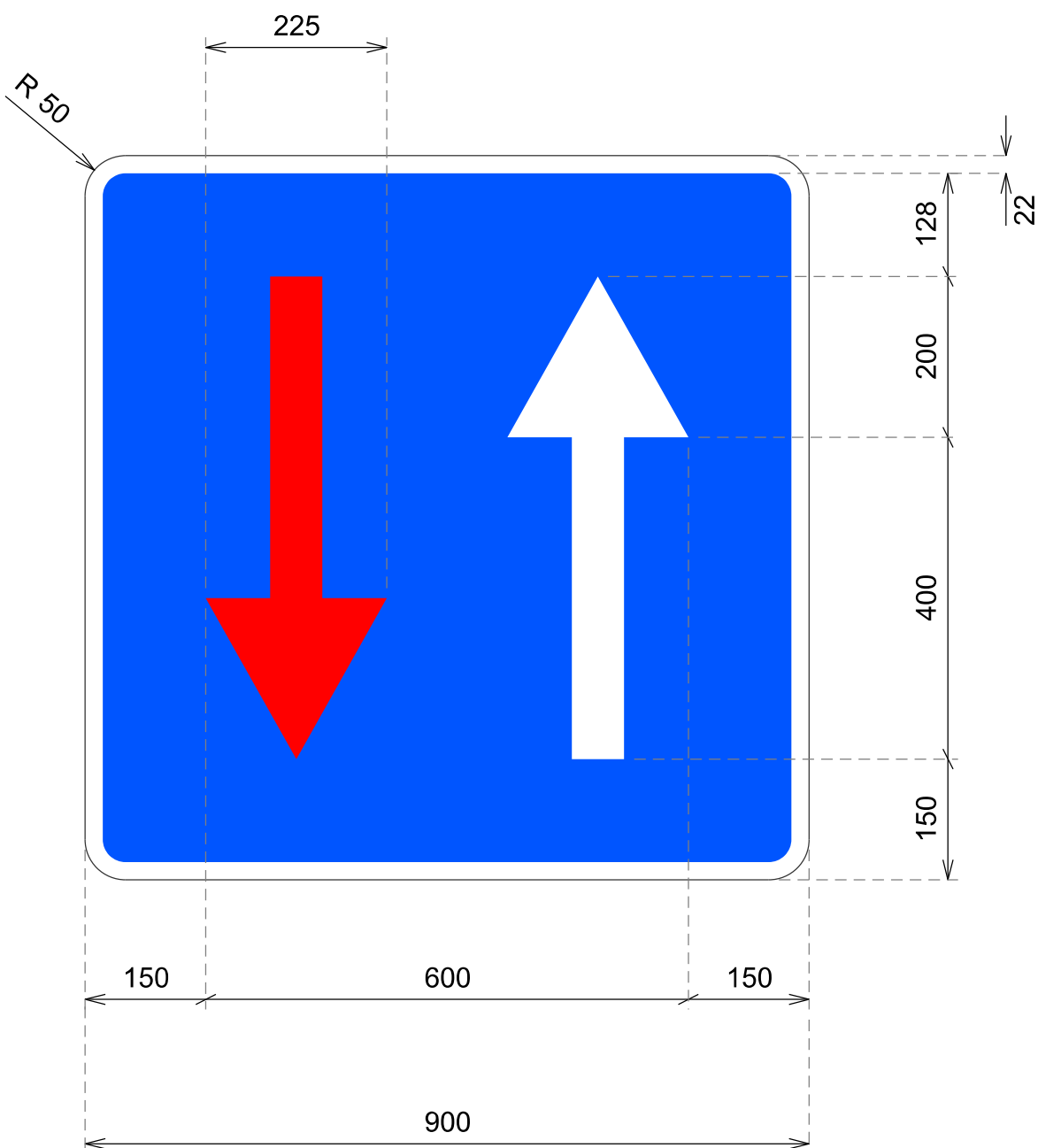

cotas en mm

Prioridad respecto al sentido contrario

R-6

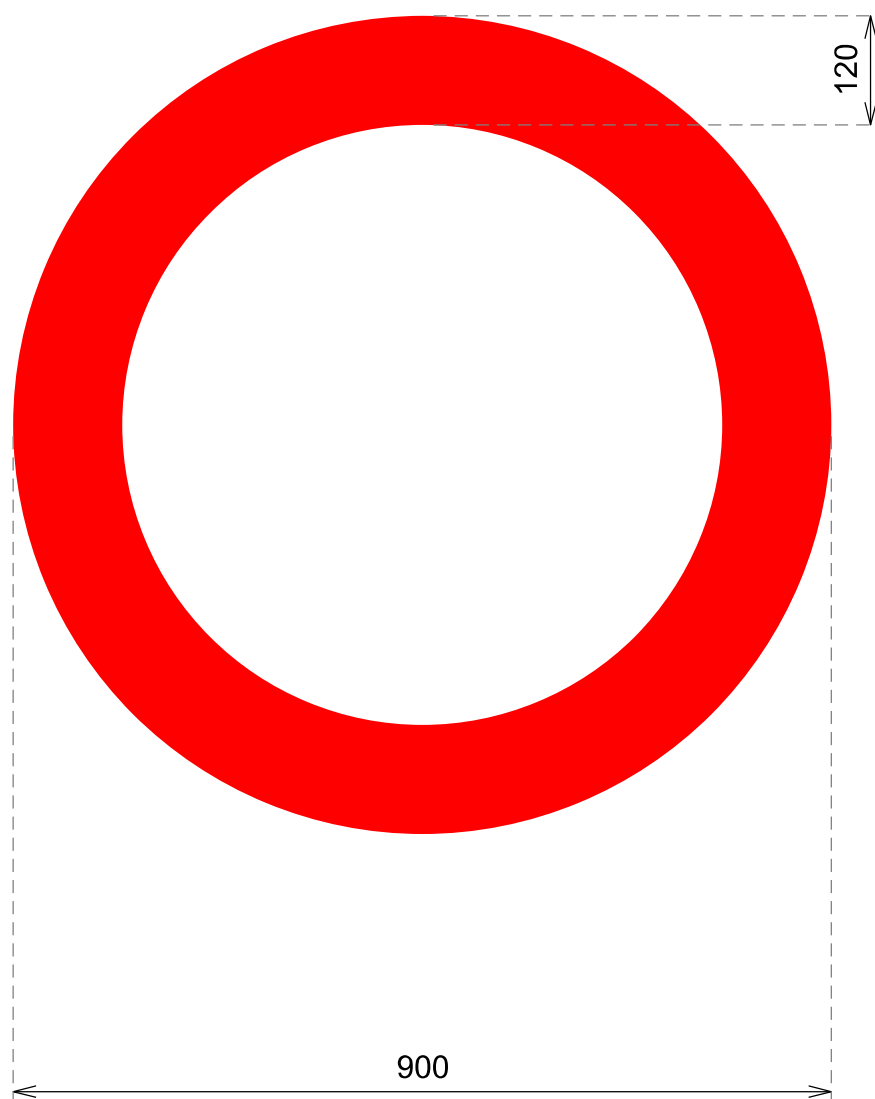

cotas en mm

Circulación prohibida

**R-100**

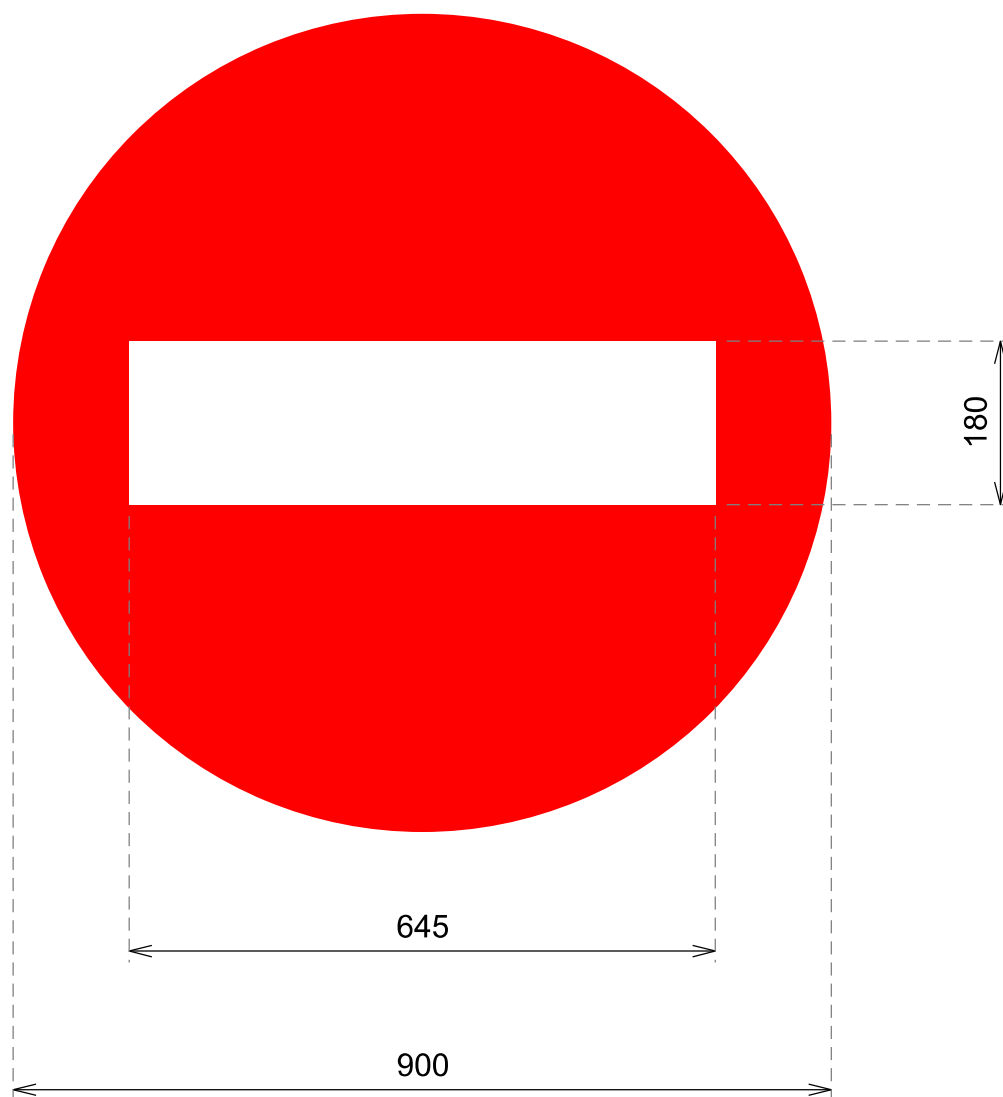

cotas en mm

Entrada prohibida

**R-101**

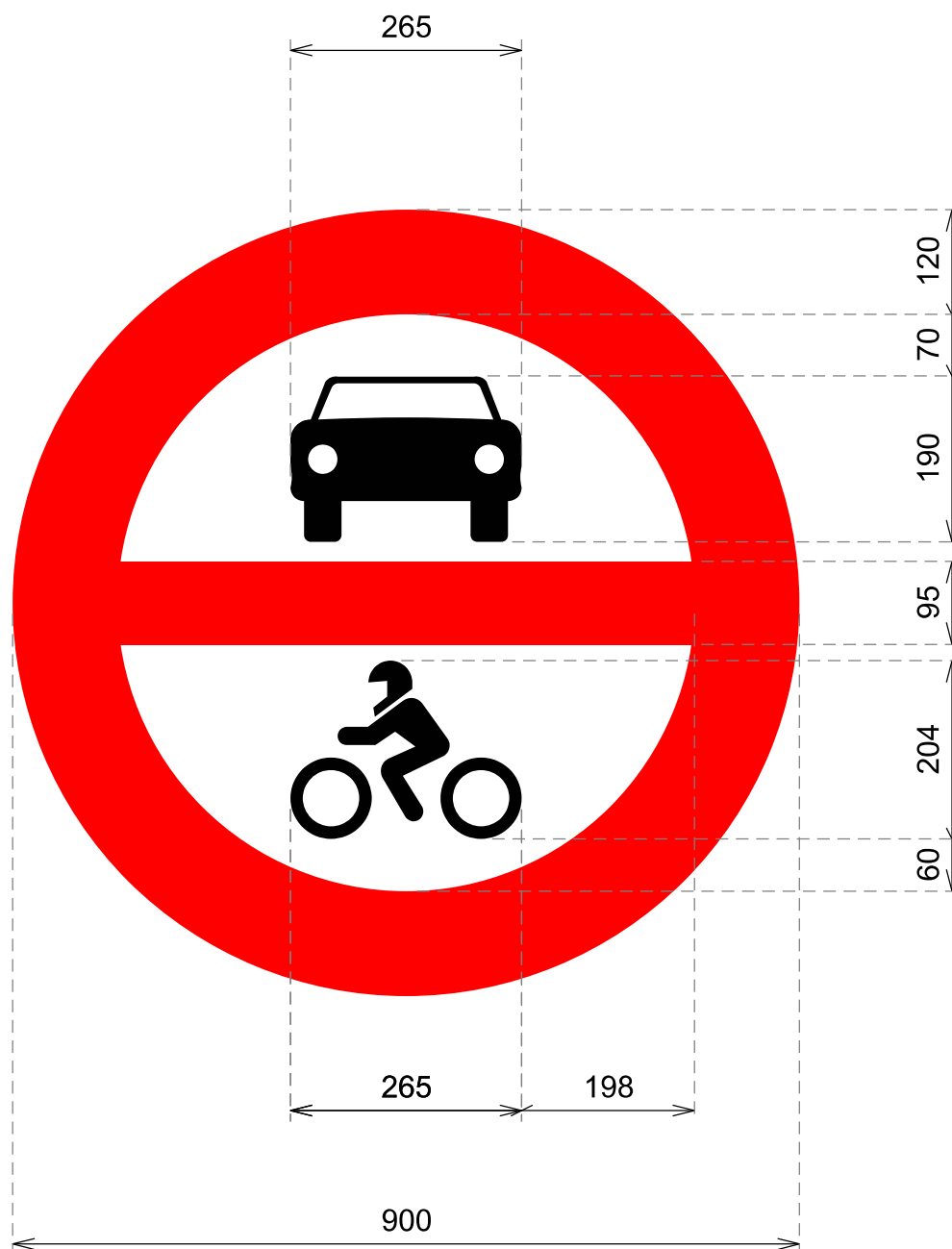

cotas en mm

Entrada prohibida a vehículos de motor

**R-102**



# SEÑALES DE REGLAMENTACIÓN

## PROHIBICIÓN DE ENTRADA

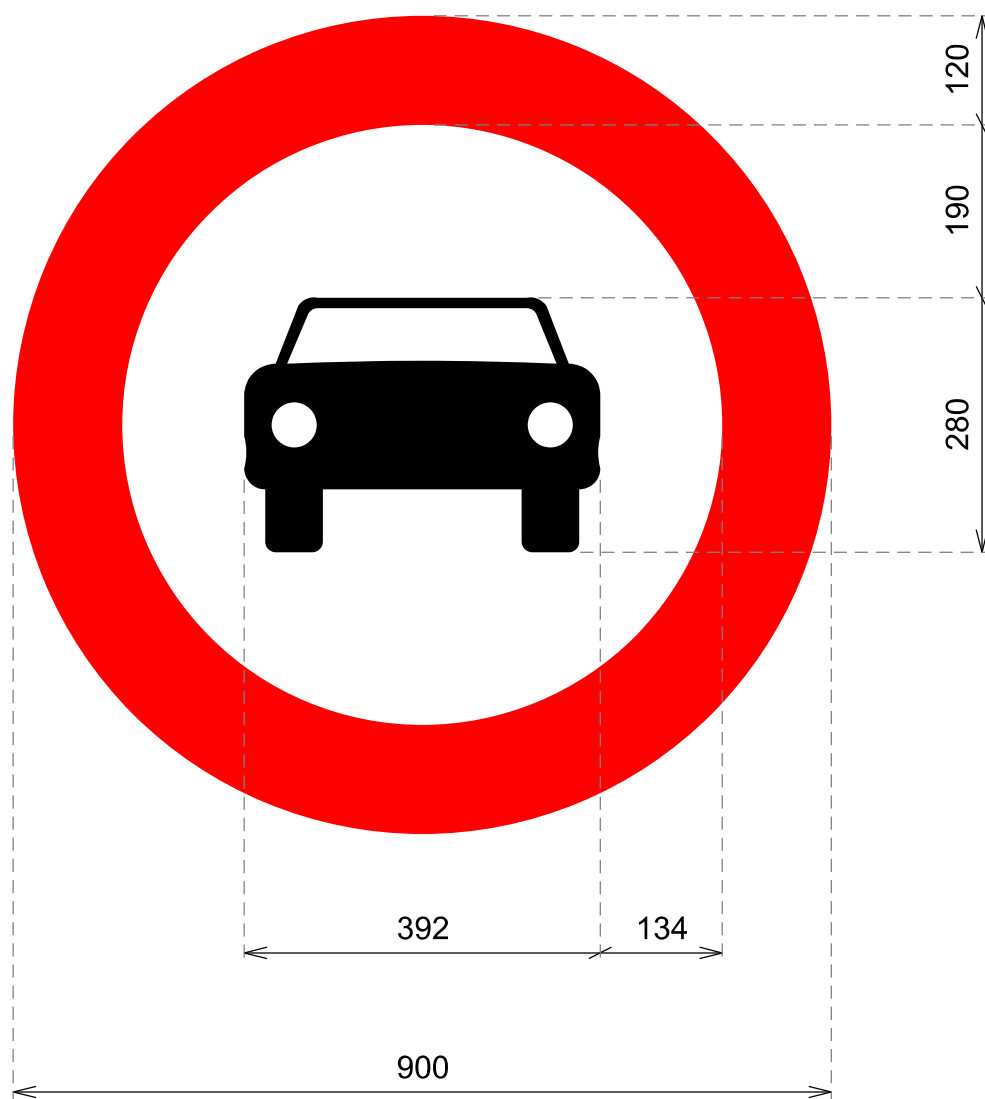

cotas en mm

Entrada prohibida a vehículos de motor,  
excepto motocicletas de dos ruedas

**R-103**



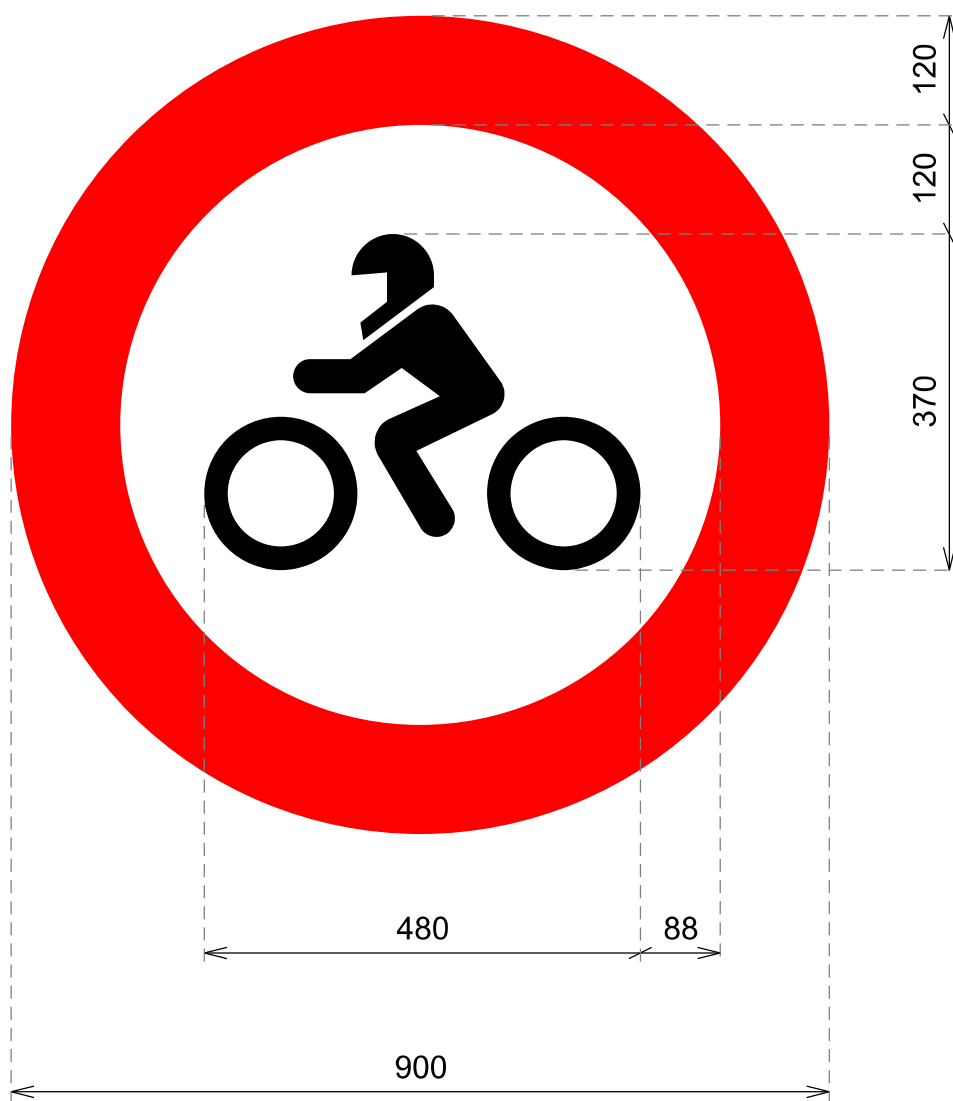

cotas en mm

Entrada prohibida a motocicletas

**R-104**

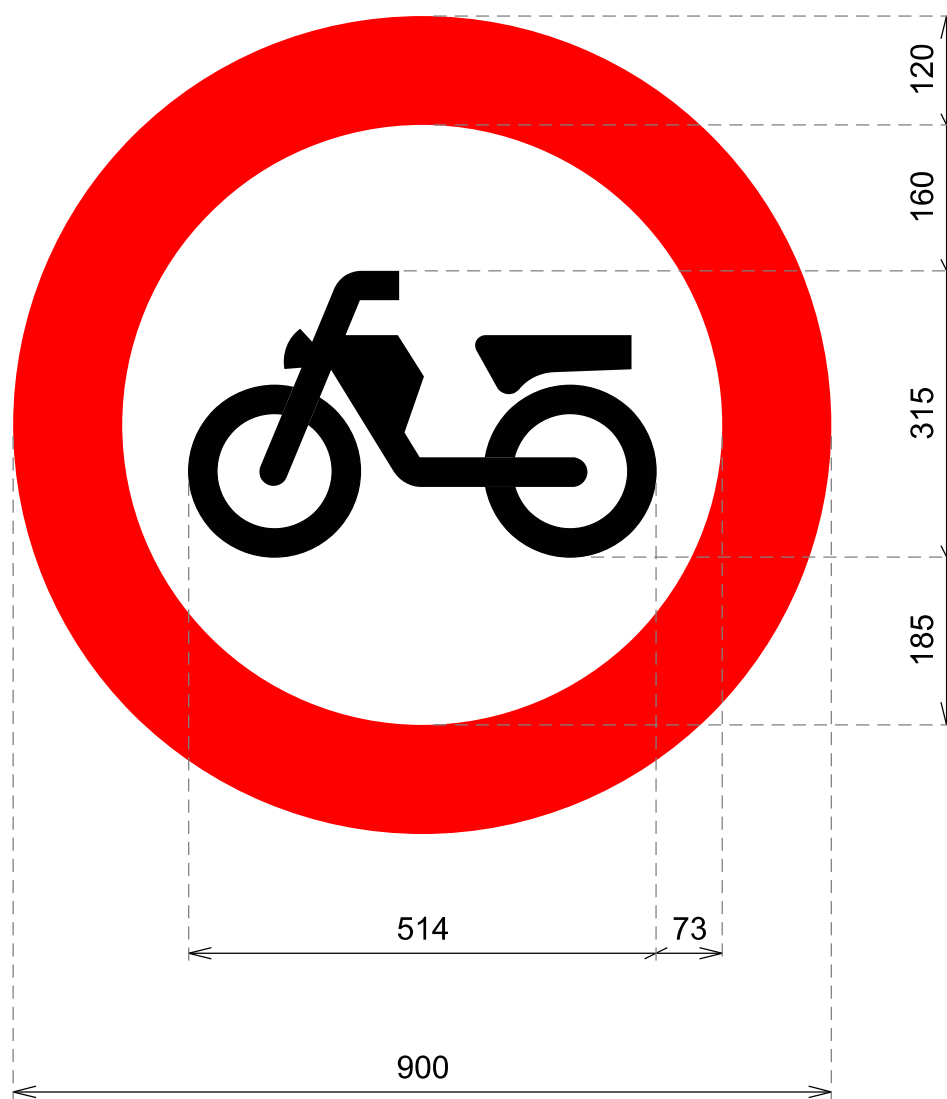

cotas en mm

Entrada prohibida a ciclomotores

**R-105**



# SEÑALES DE REGLAMENTACIÓN

## PROHIBICIÓN DE ENTRADA

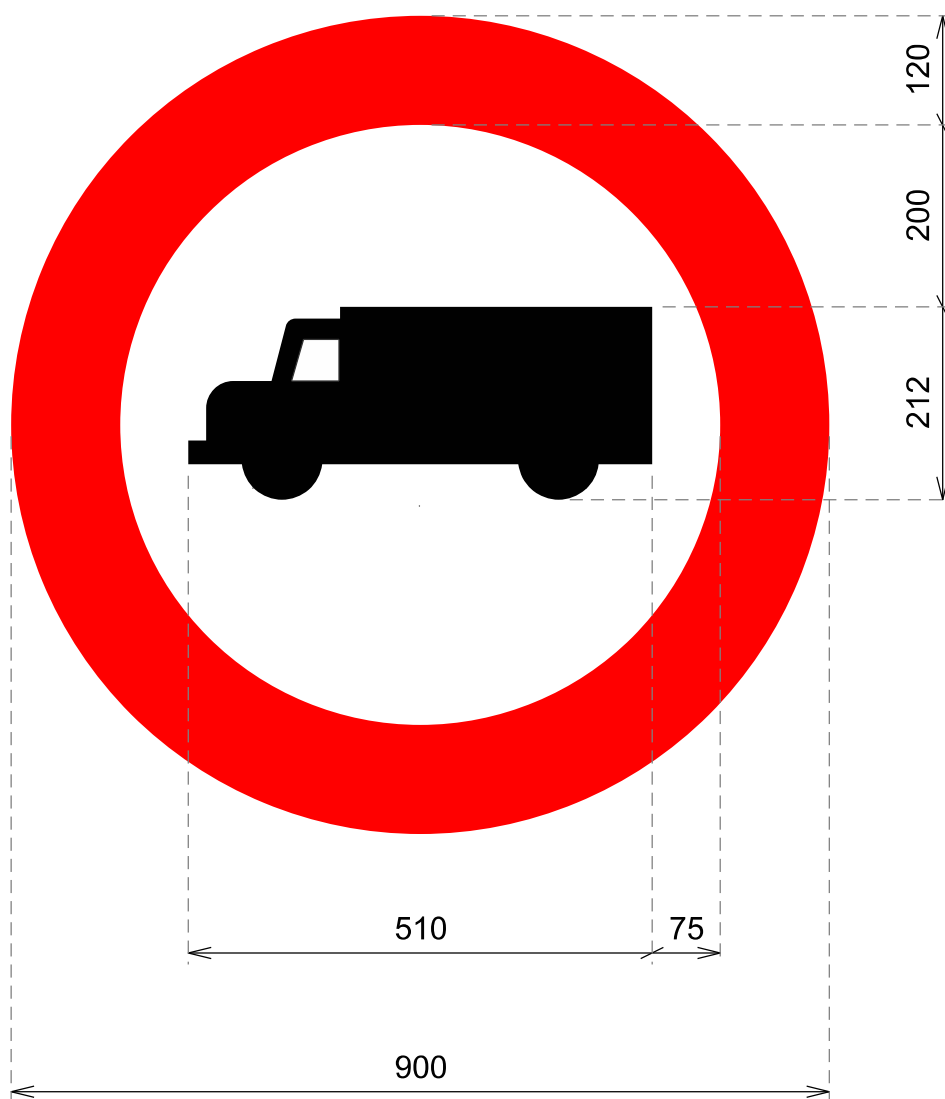

cotas en mm

Entrada prohibida a vehículos destinados al transporte de mercancías

**R-106**

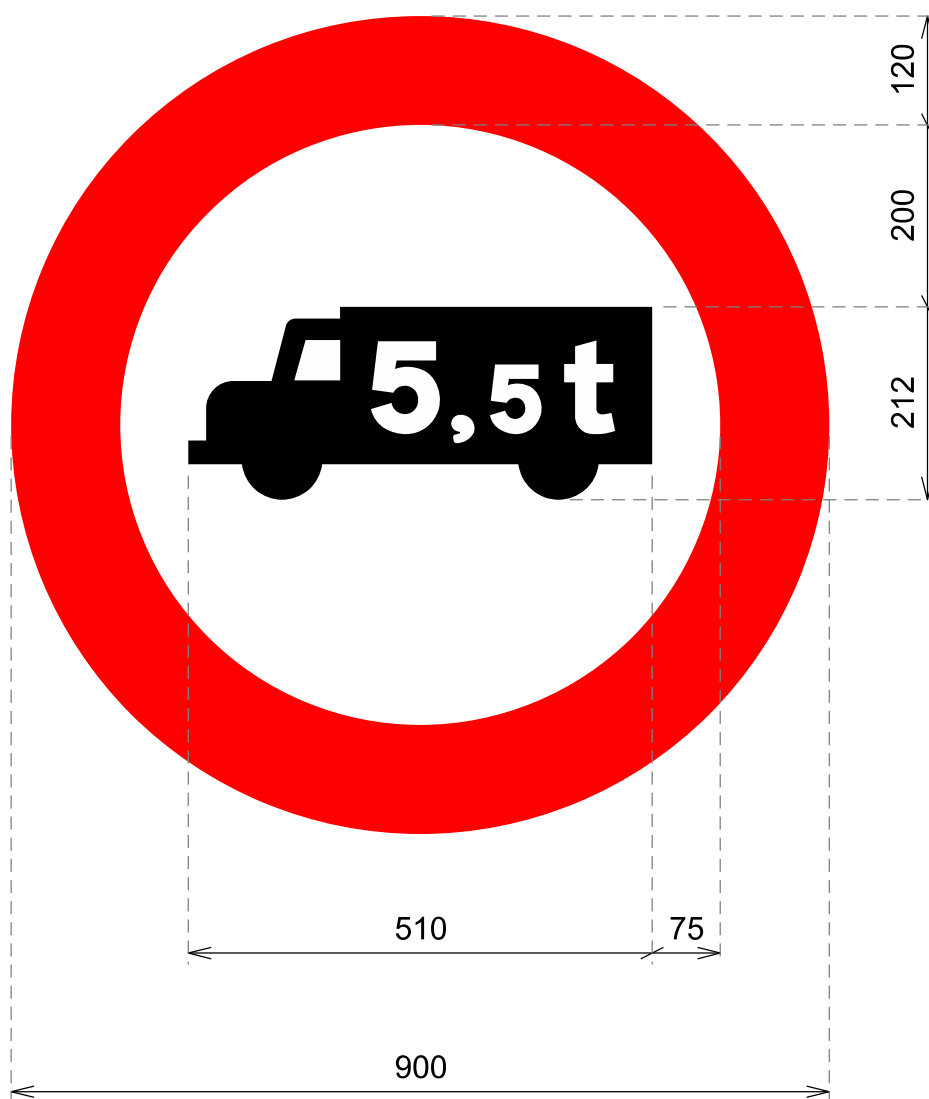

cotas en mm

Entrada prohibida a vehículos destinados al transporte de mercancías con mayor masa autorizada que la indicada

**R-107**



# SEÑALES DE REGLAMENTACIÓN

## PROHIBICIÓN DE ENTRADA

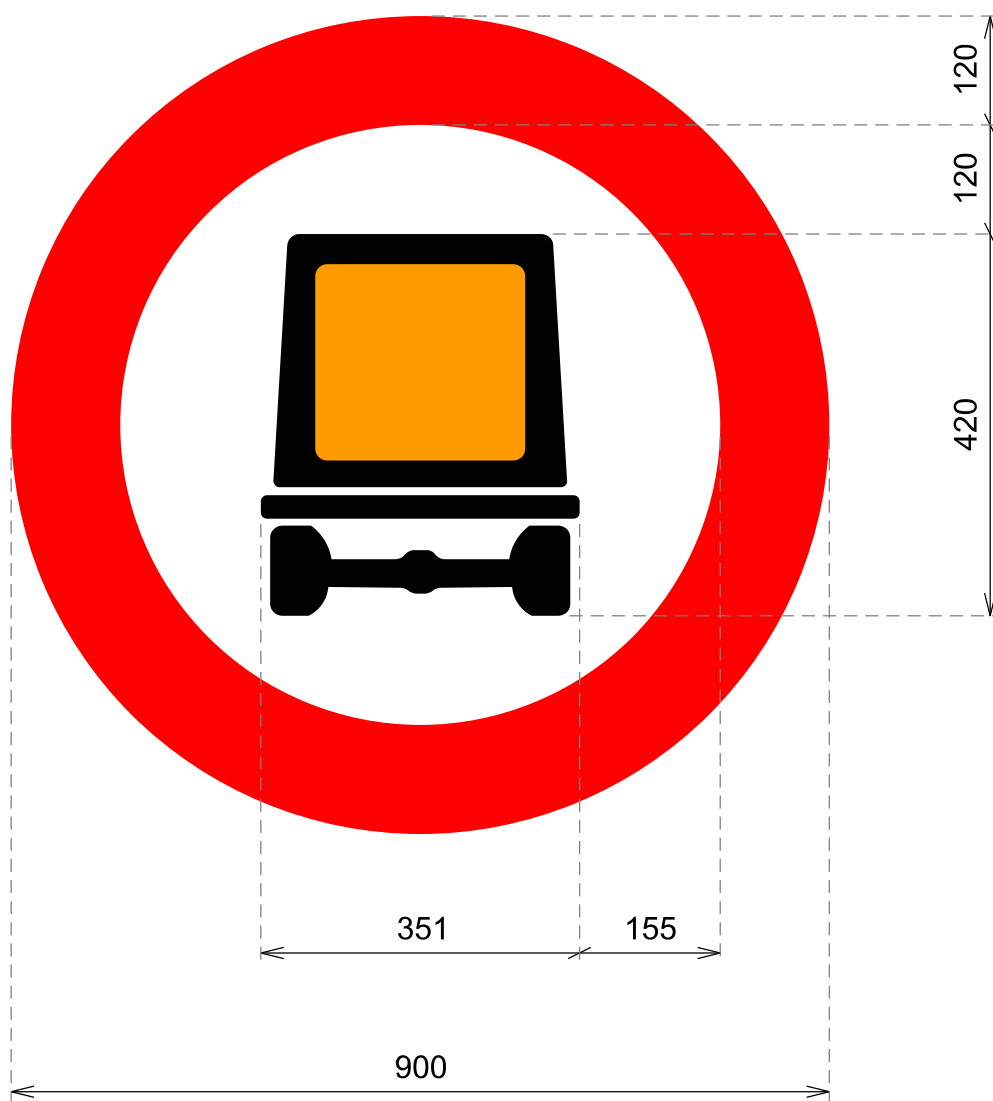

cotas en mm

Entrada prohibida a vehículos que transporten mercancías peligrosas

**R-108**



# SEÑALES DE REGLAMENTACIÓN

## PROHIBICIÓN DE ENTRADA

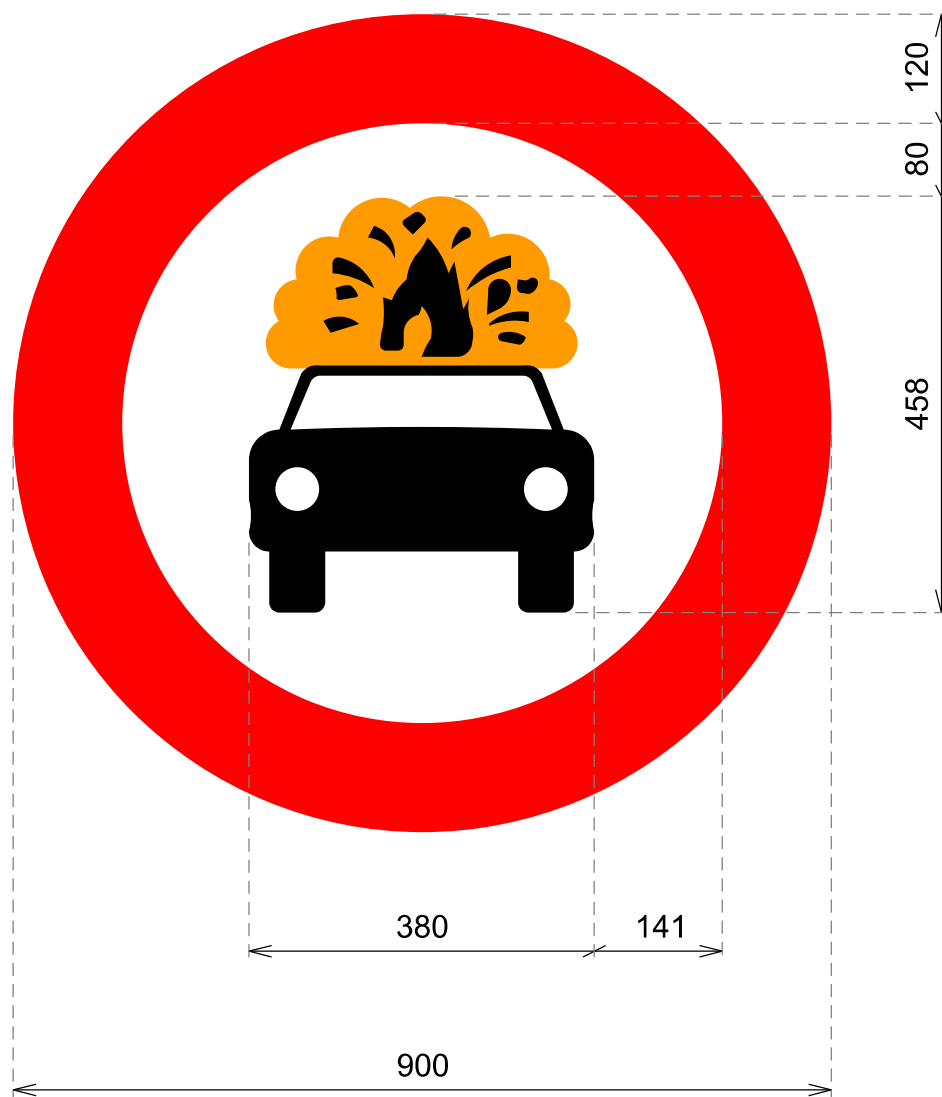

cotas en mm

Entrada prohibida a vehículos que transporten mercancías explosivas o inflamables

**R-109**

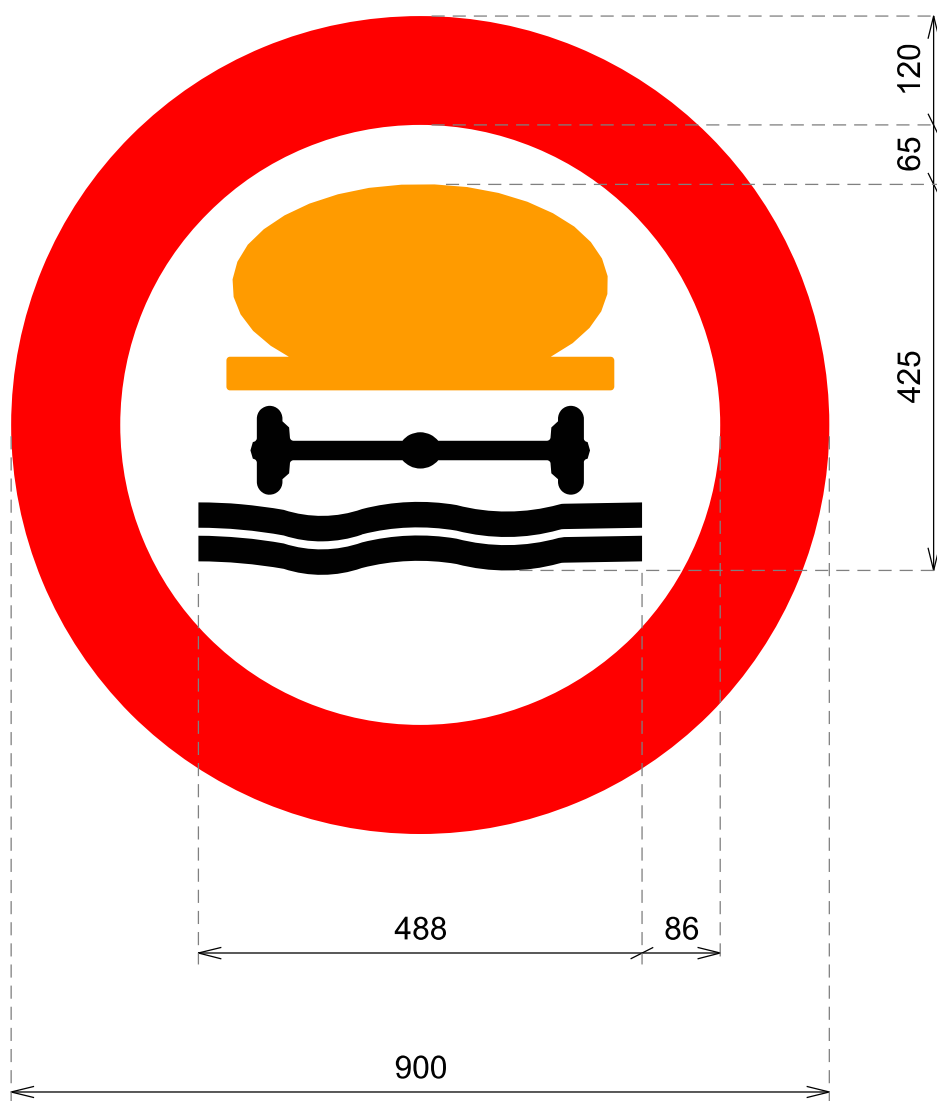

cotas en mm

Entrada prohibida a vehículos que transporten  
productos contaminantes del agua

**R-110**

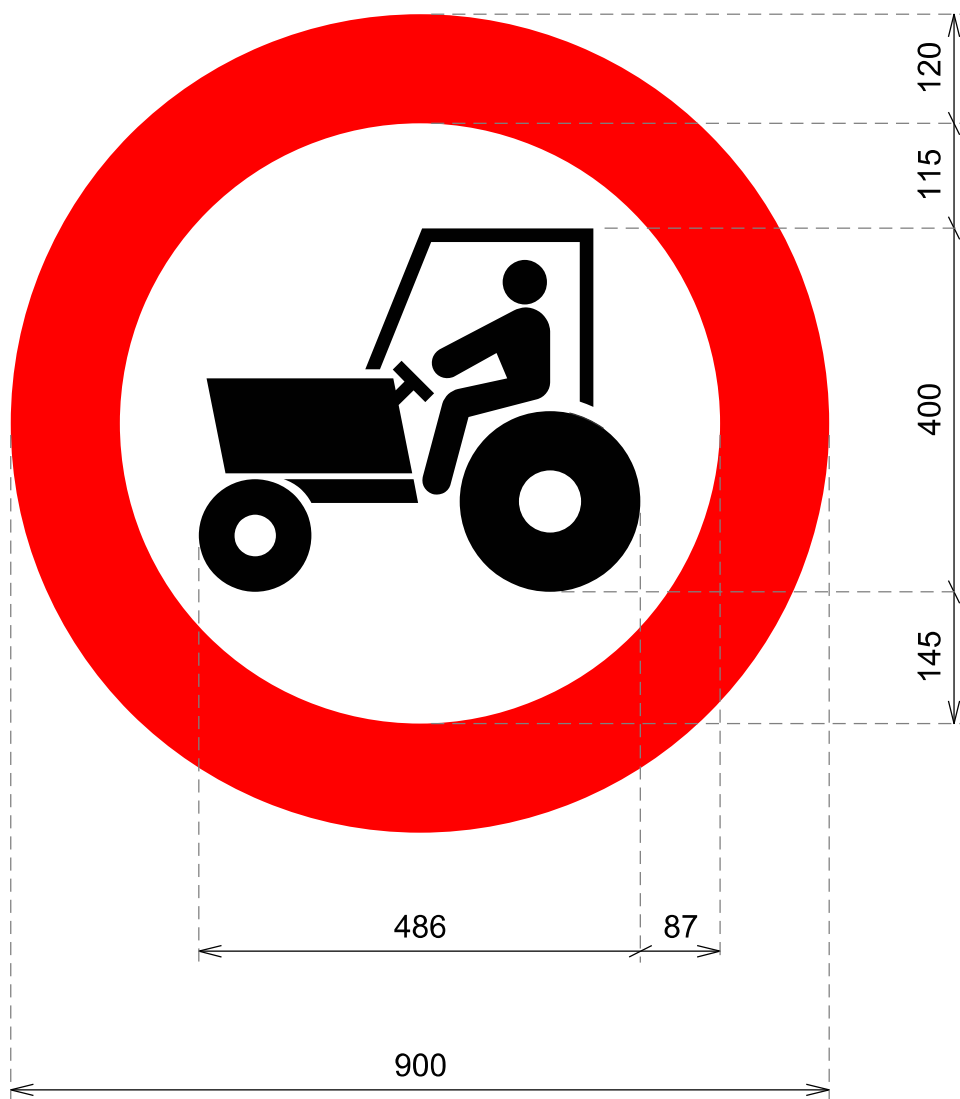

cotas en mm

Entrada prohibida a vehículos agrícolas de motor

**R-111**



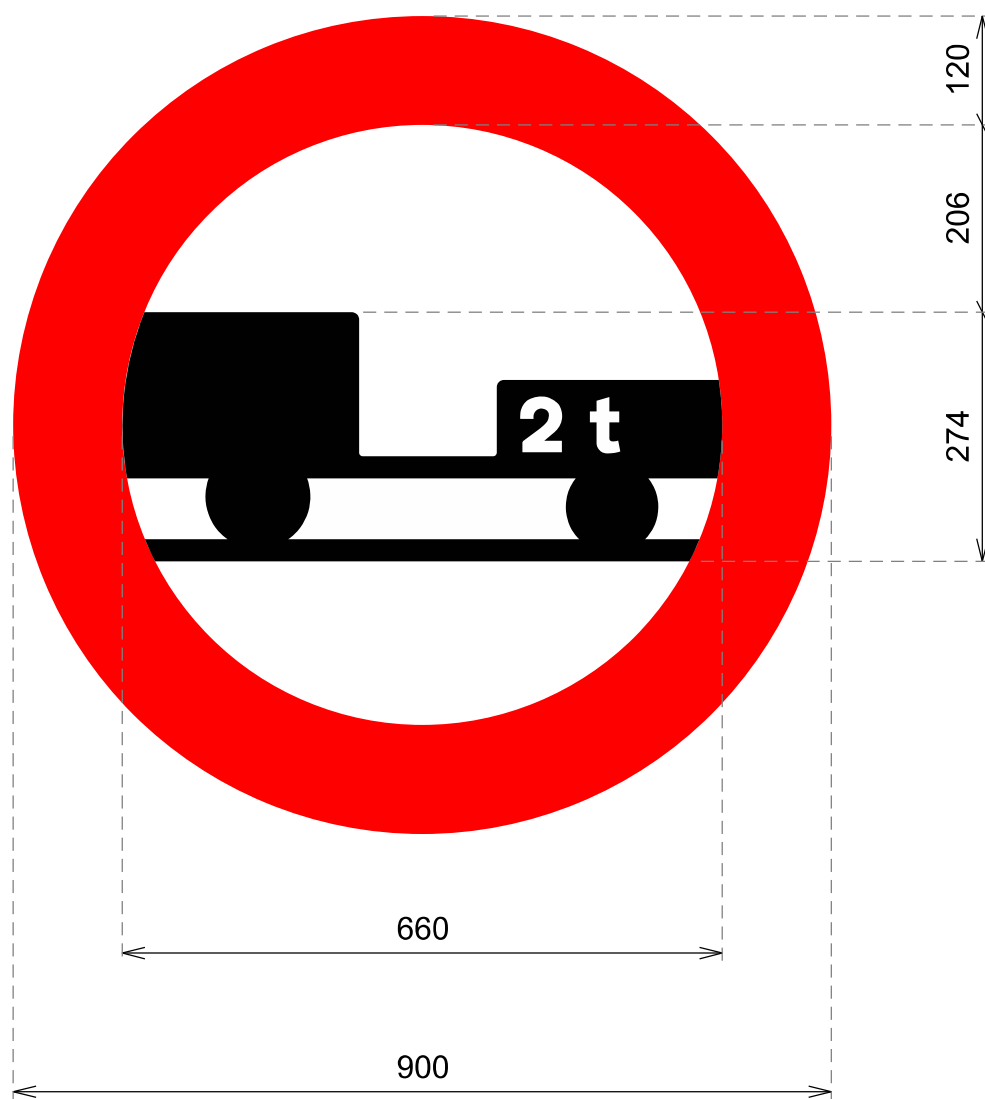

cotas en mm

Entrada prohibida a vehículos de motor con remolque  
exceptuando los de un solo eje

**R-112**

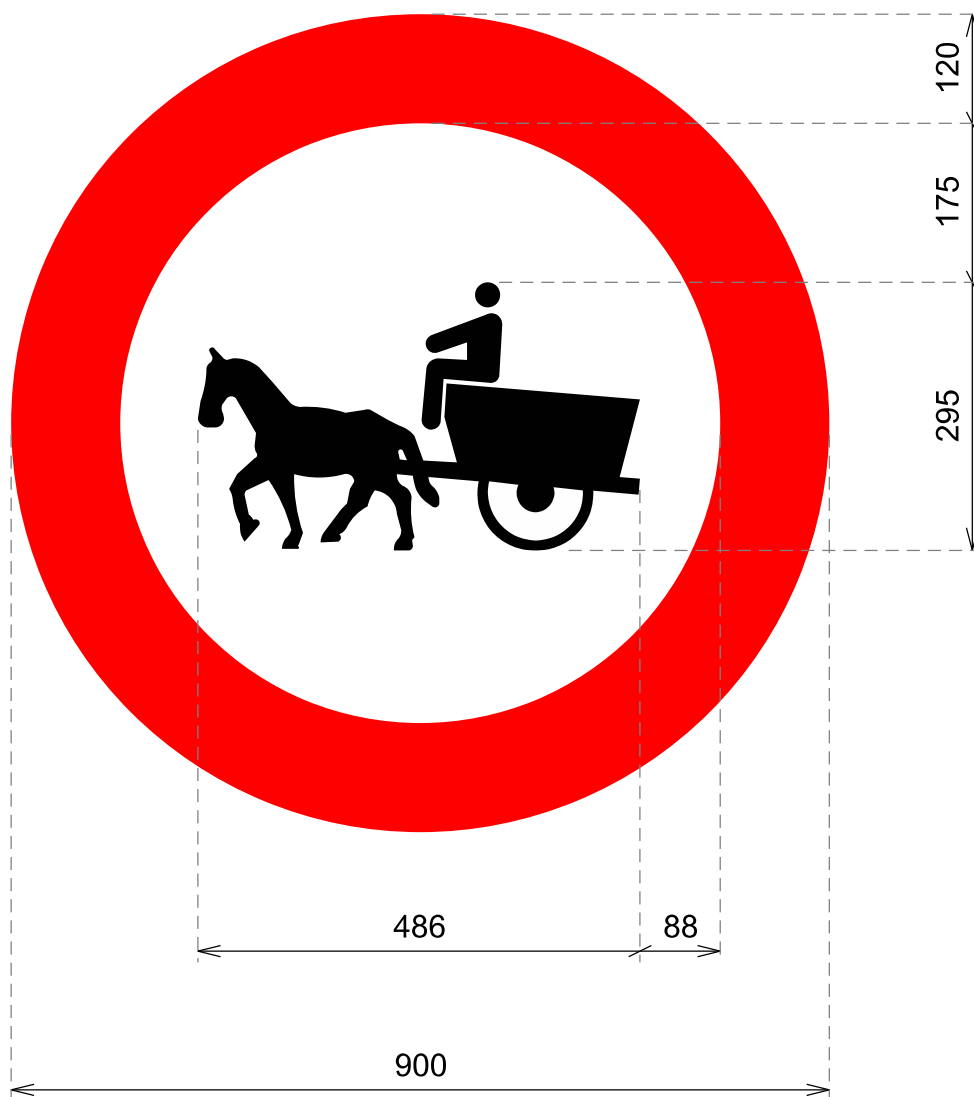

cotas en mm

Entrada prohibida a vehículos de tracción animal

**R-113**

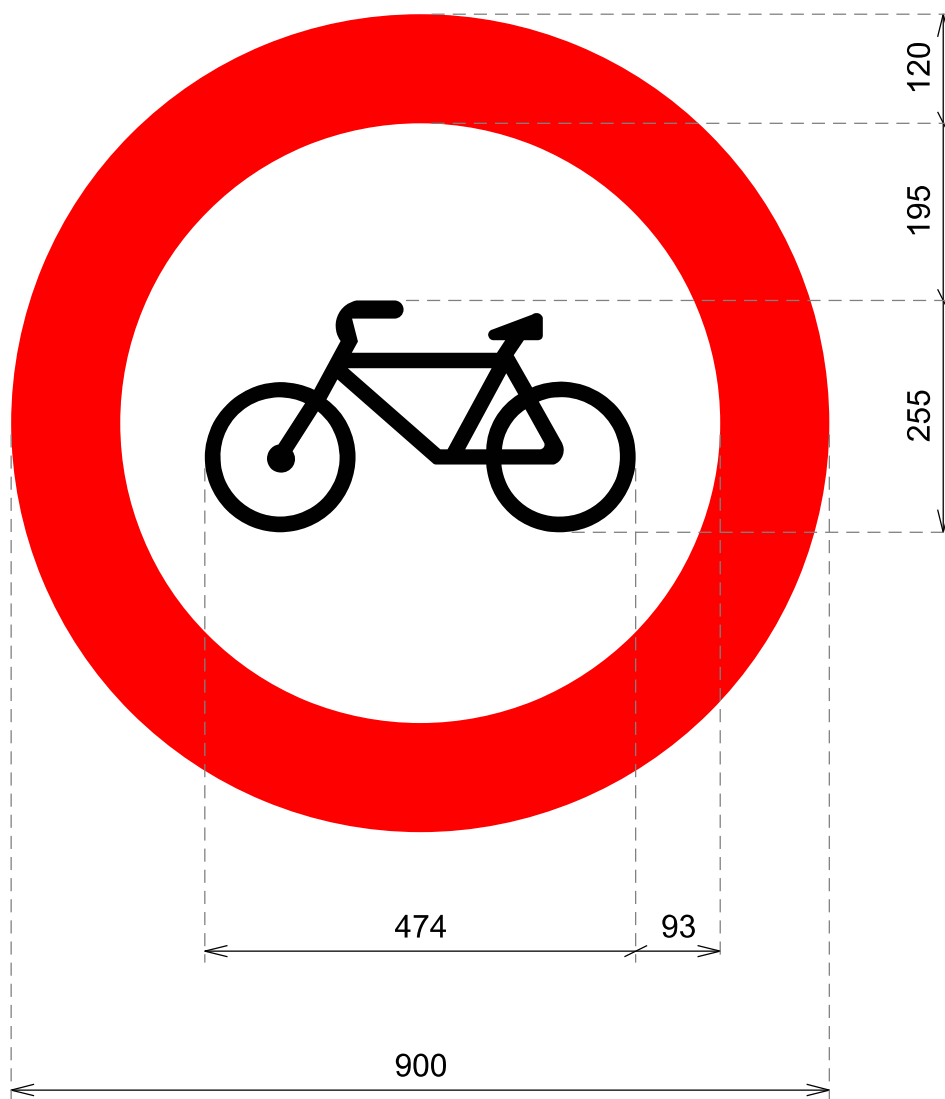

cotas en mm

Entrada prohibida a ciclos

**R-114**

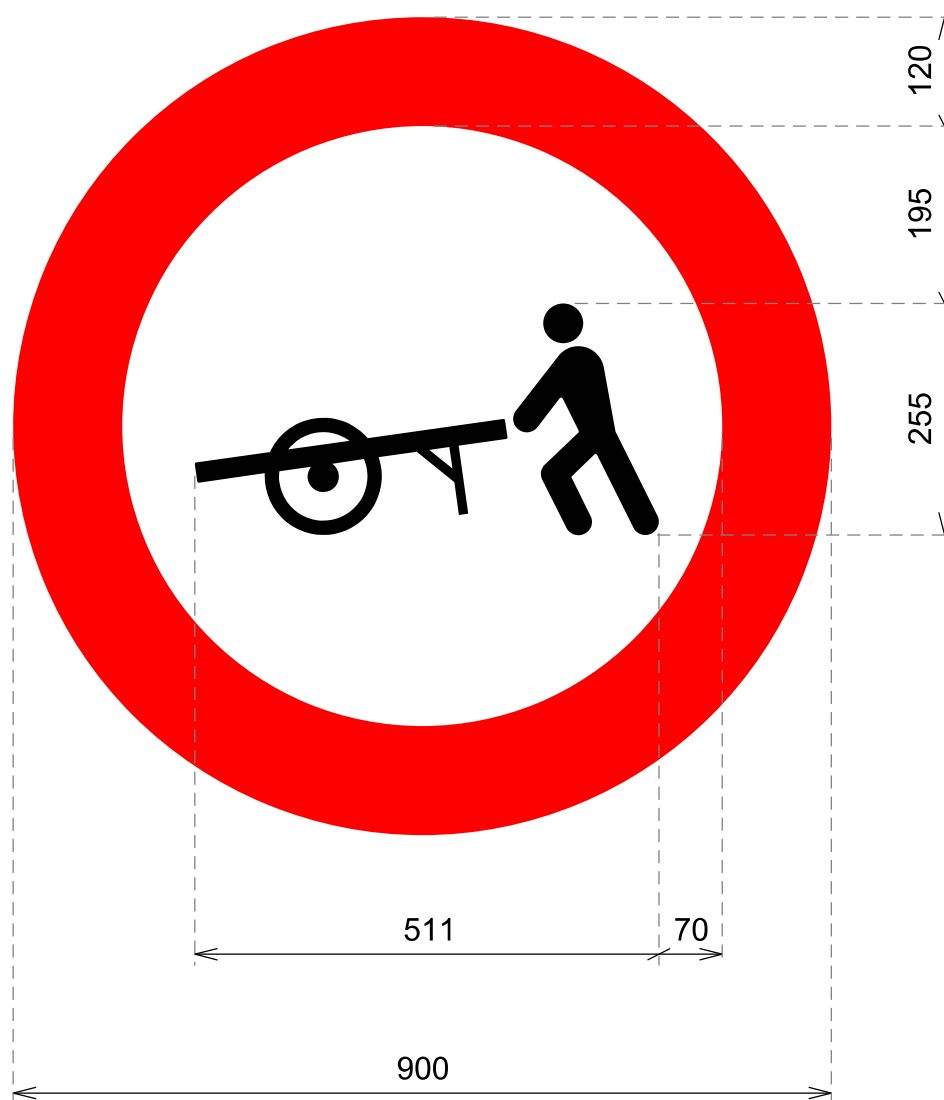

cotas en mm

Entrada prohibida a carros de mano

**R-115**

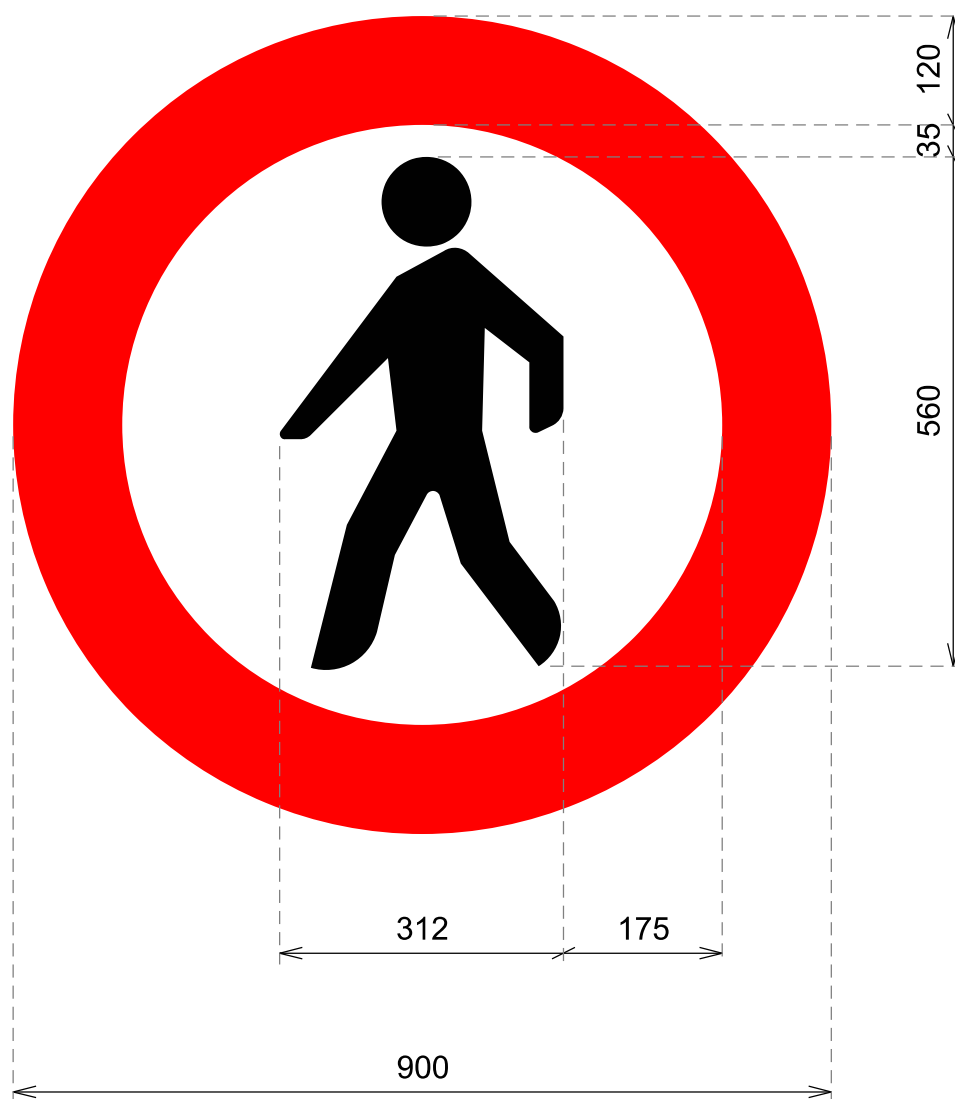

cotas en mm

Entrada prohibida a peatones

**R-116**



# SEÑALES DE REGLAMENTACIÓN

## PROHIBICIÓN DE ENTRADA

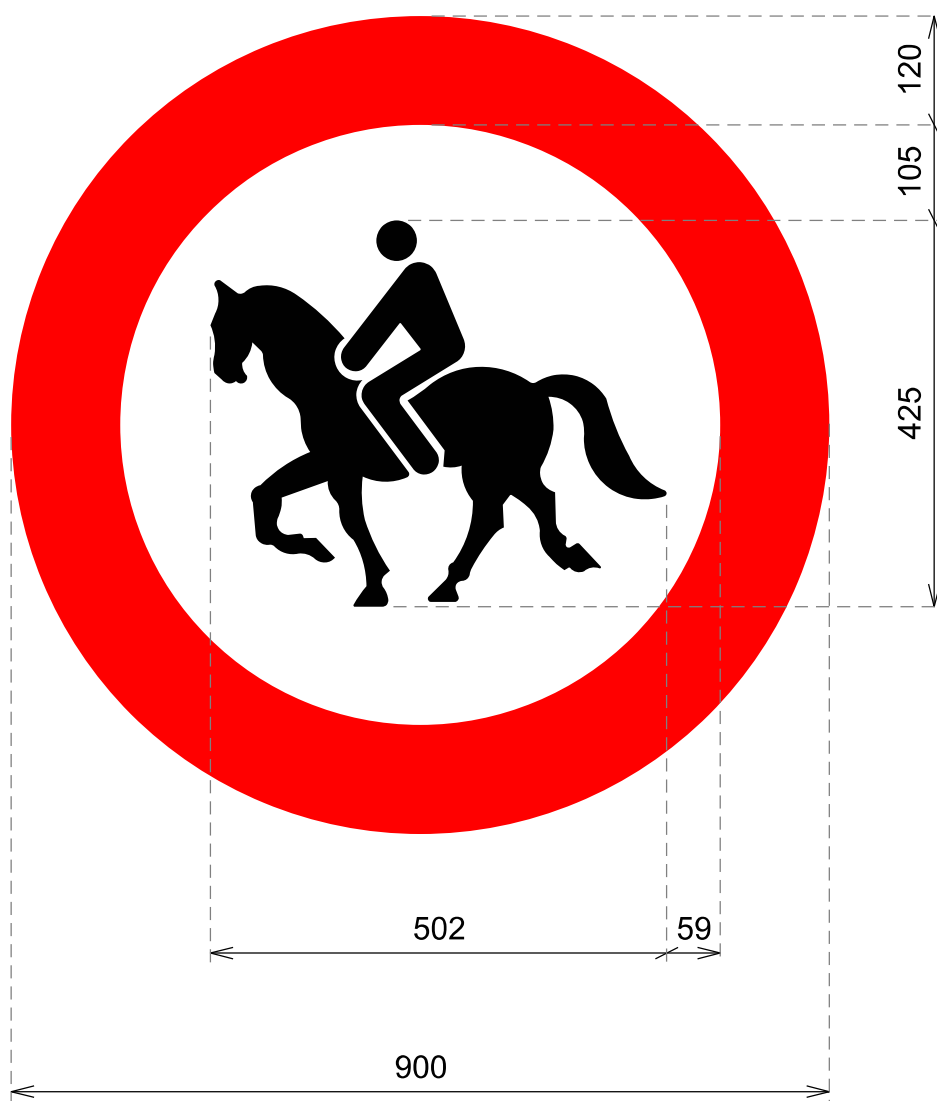

cotas en mm

Entrada prohibida a animales de montura

**R-117**

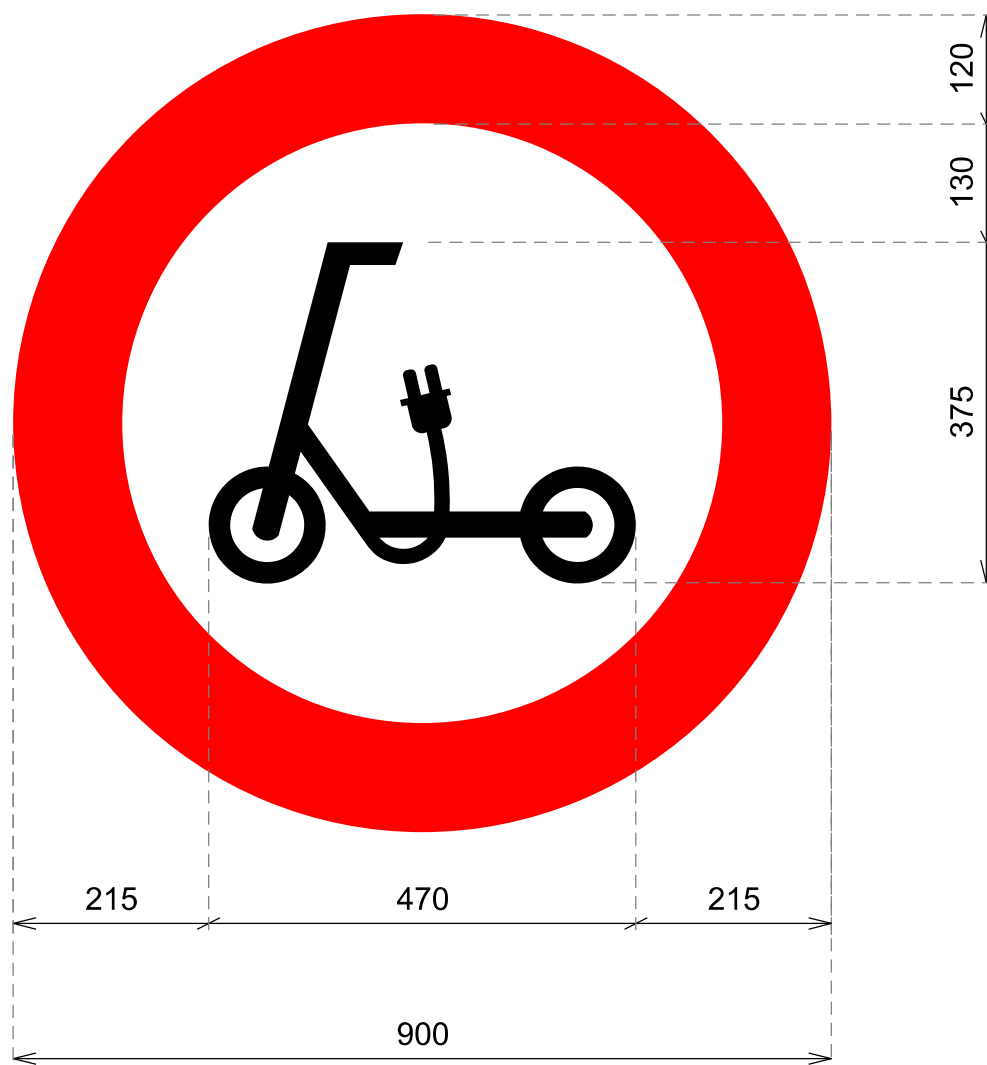

cotas en mm

Entrada prohibida a vehículos de movilidad personal

**R-118**



# SEÑALES DE REGLAMENTACIÓN

## PROHIBICIÓN DE ENTRADA

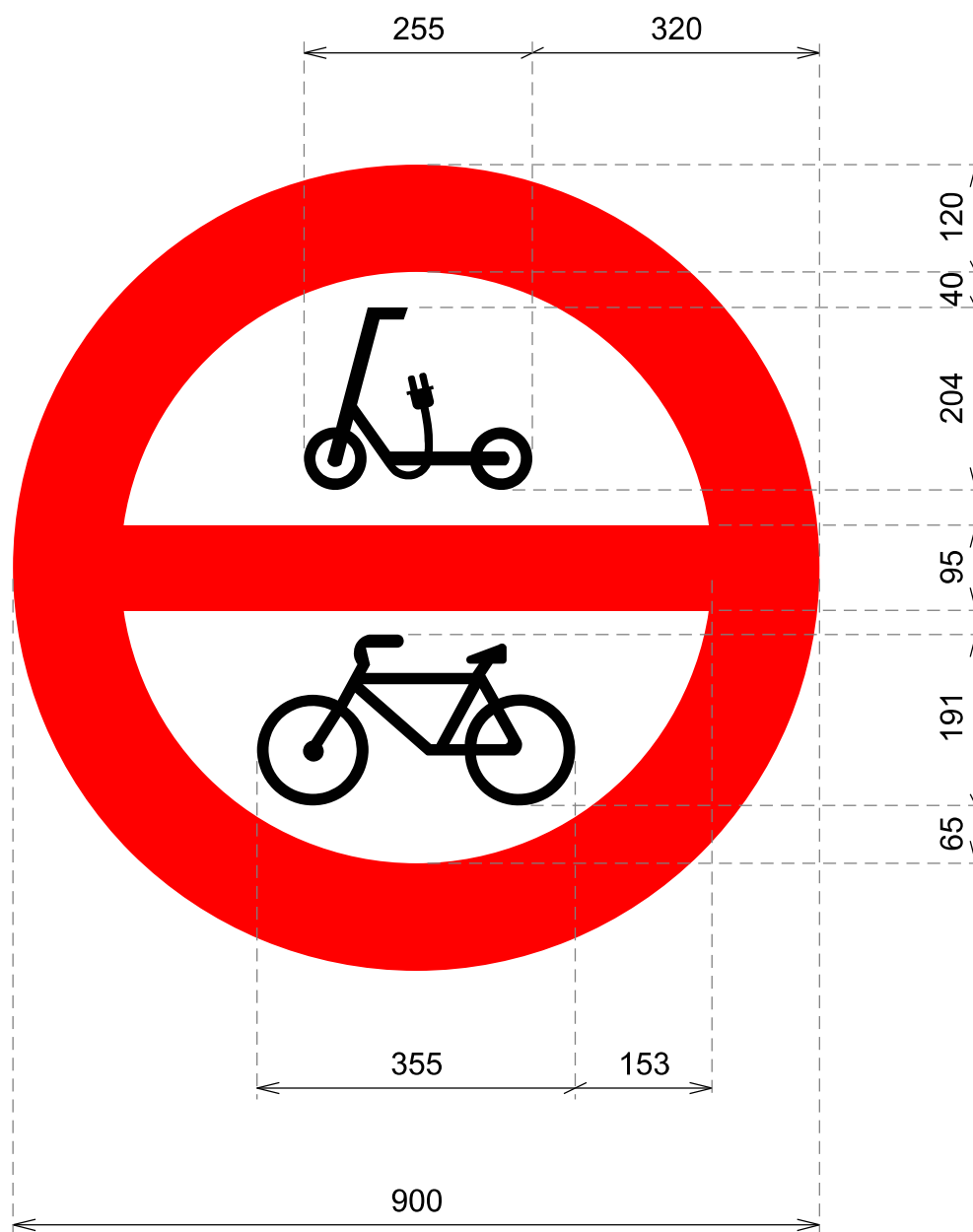

cotas en mm

Entrada prohibida a ciclos y a  
vehículos de movilidad personal

**R-119**



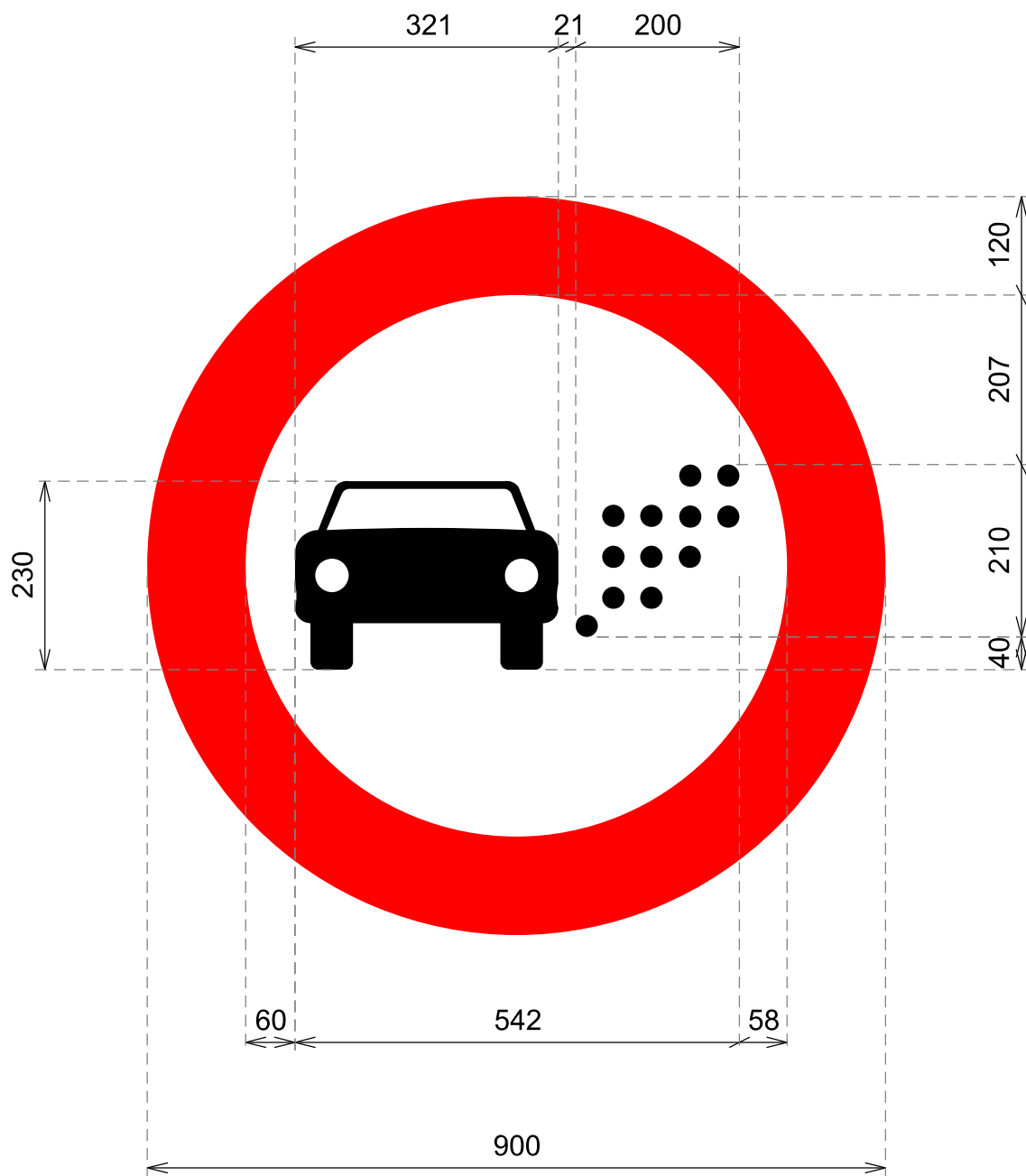

cotas en mm

Entrada prohibida a vehículos  
en función de su distintivo ambiental

R-120

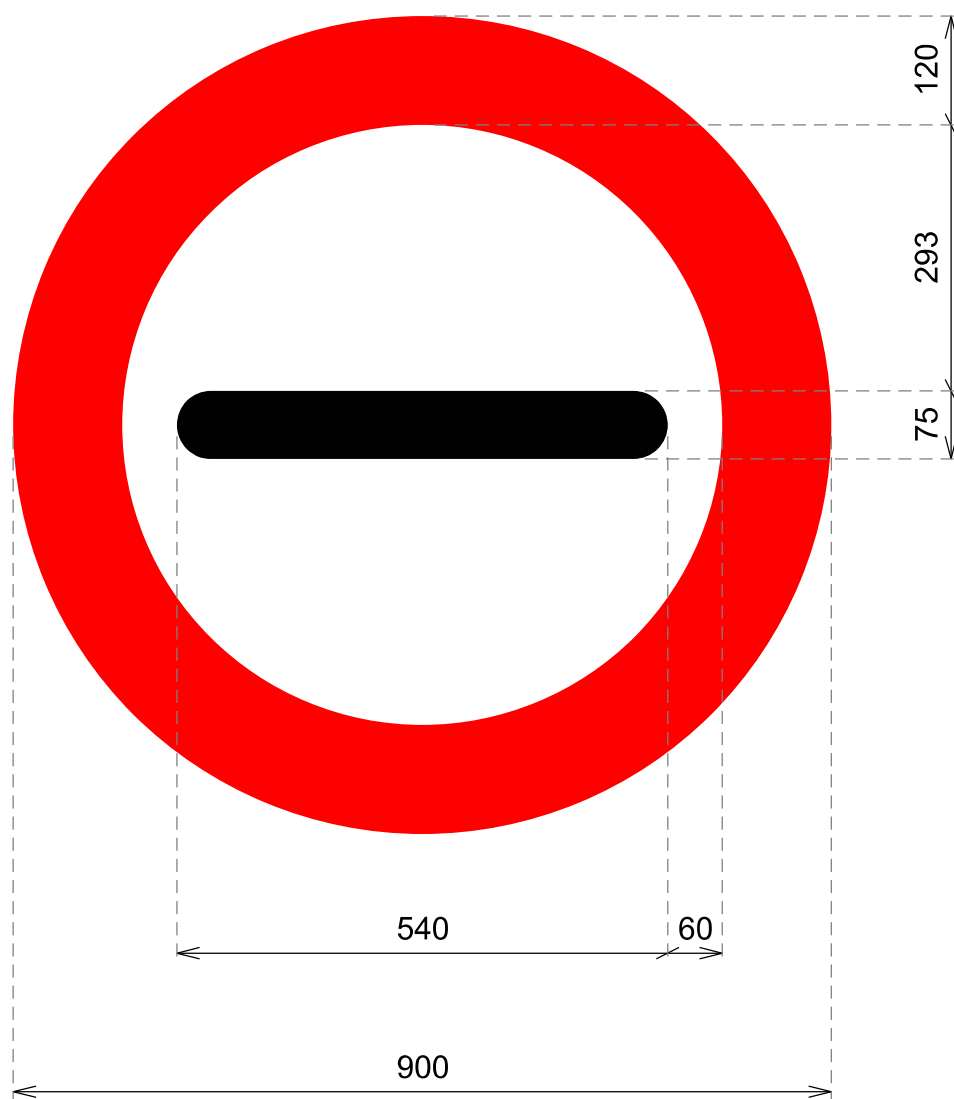

cotas en mm

Prohibición de pasar sin detenerse

**R-200**

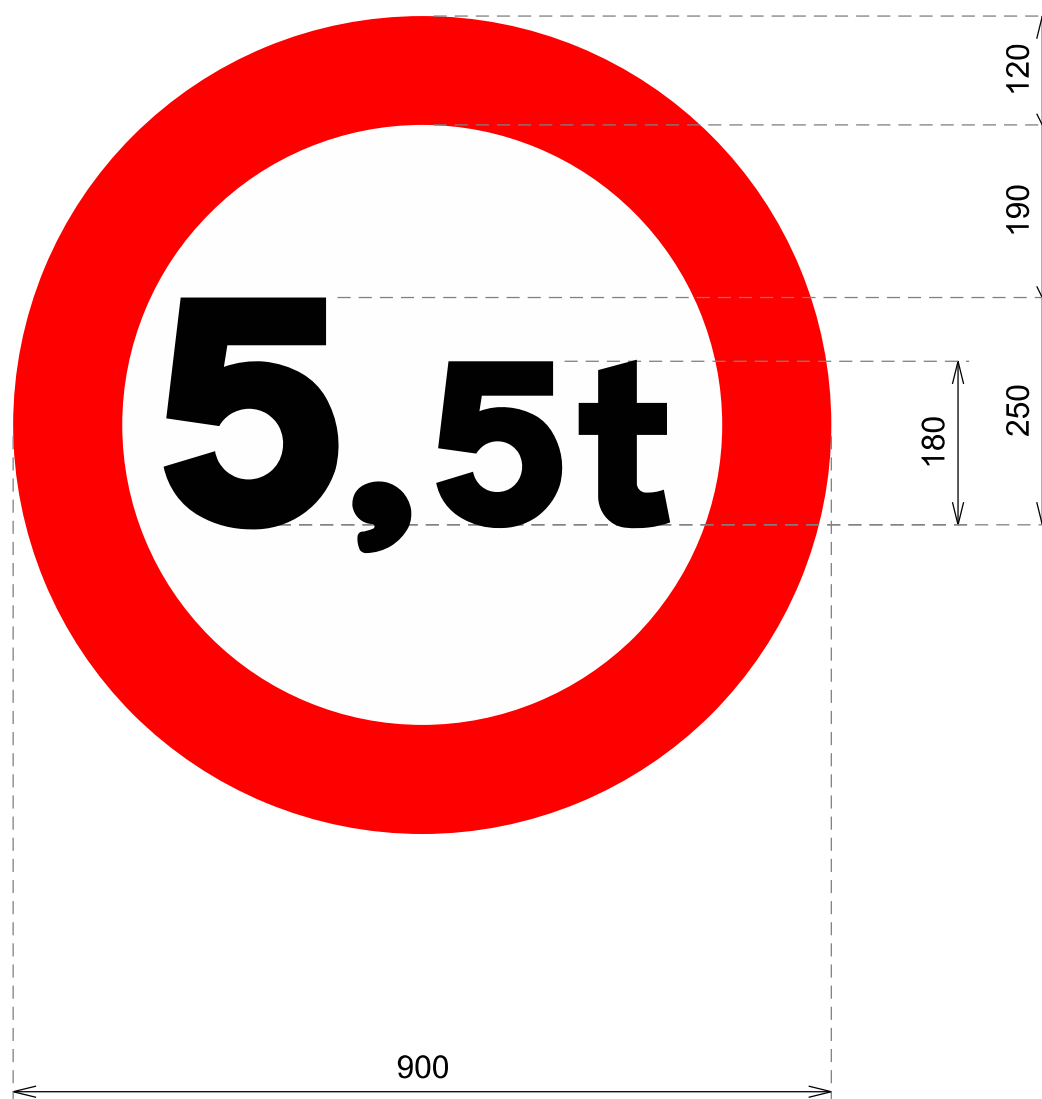

cotas en mm

Limitación de masa

**R-201**

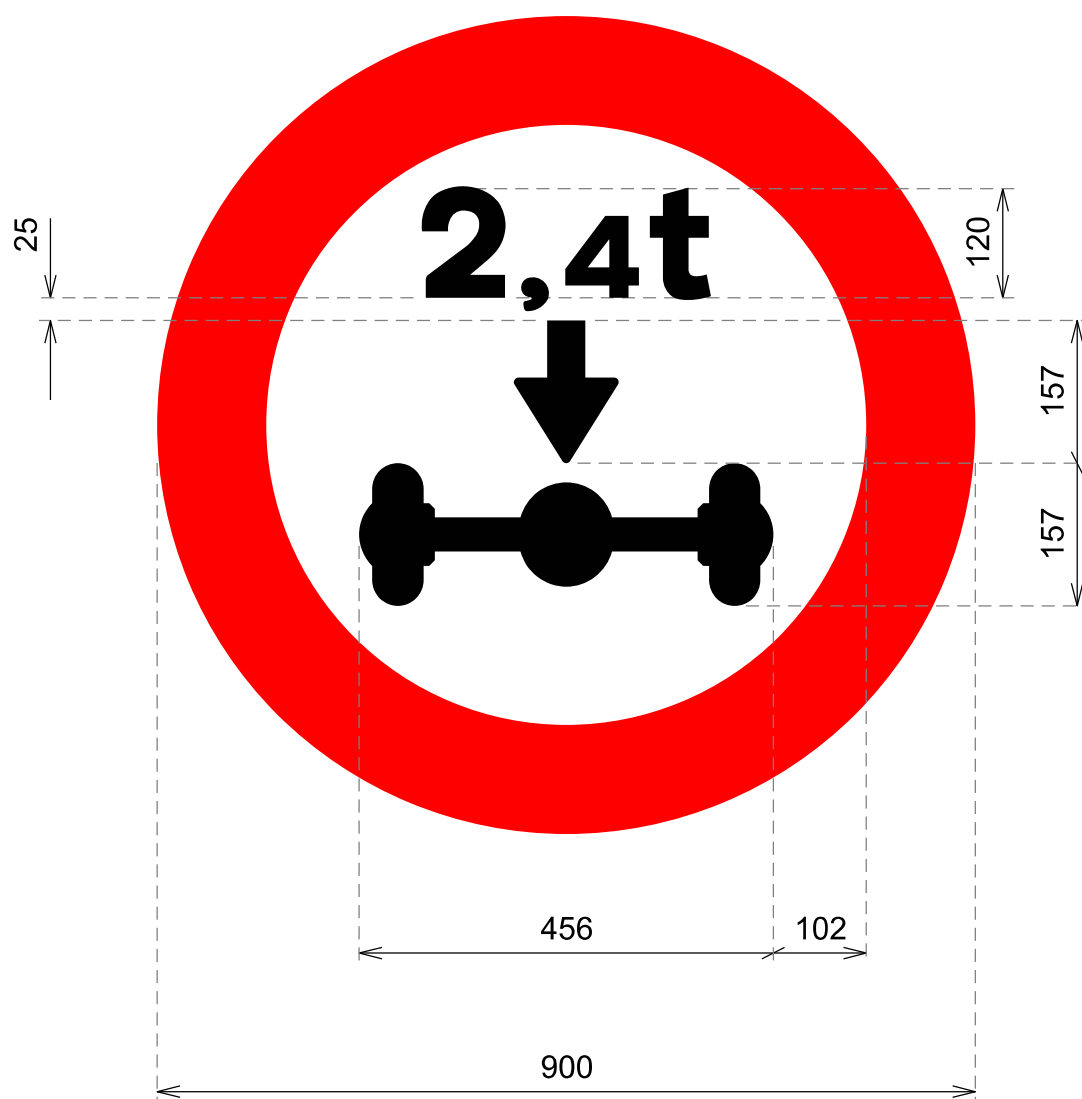

cotas en mm

Limitación de masa por eje

**R-202**

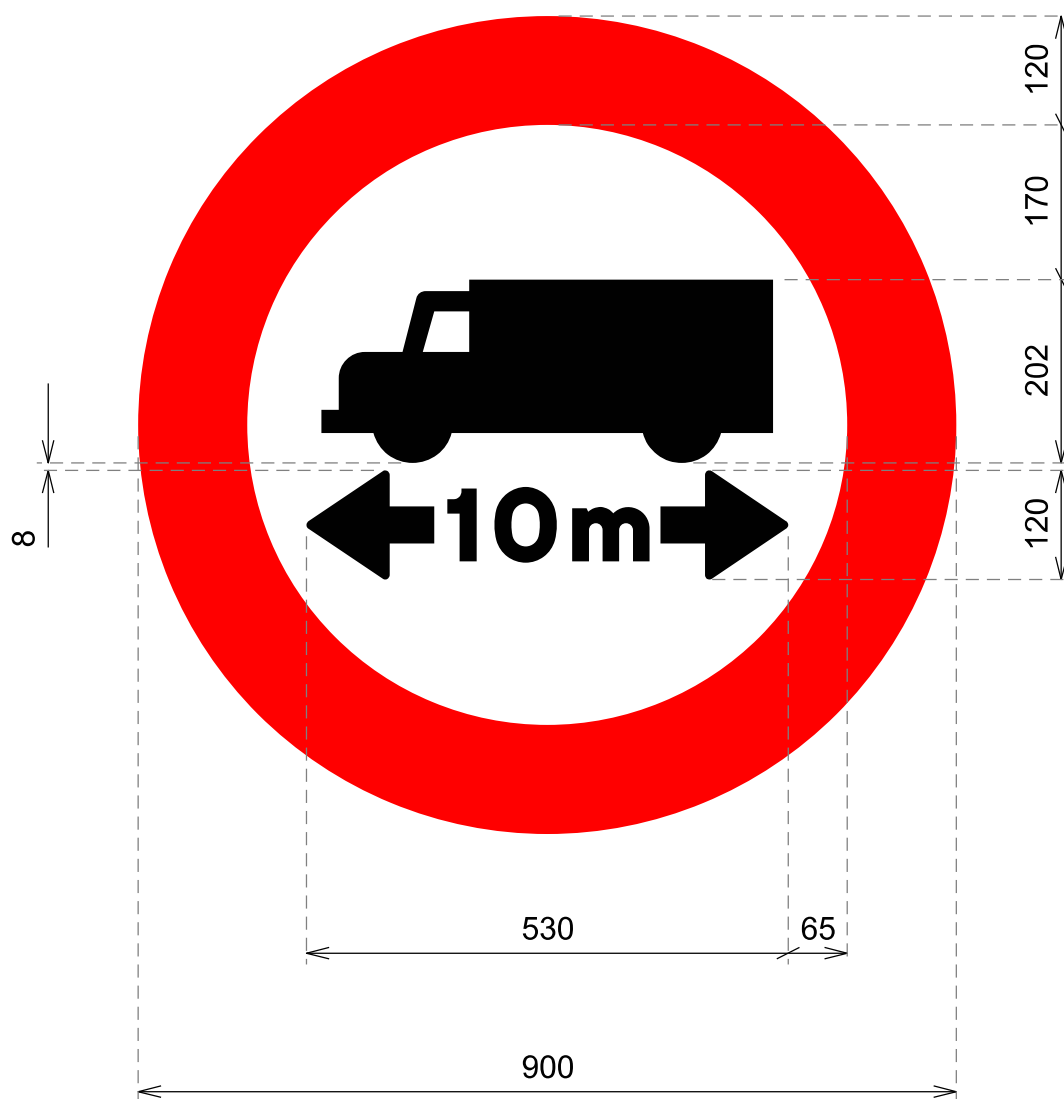

cotas en mm

Limitación de longitud

**R-203**

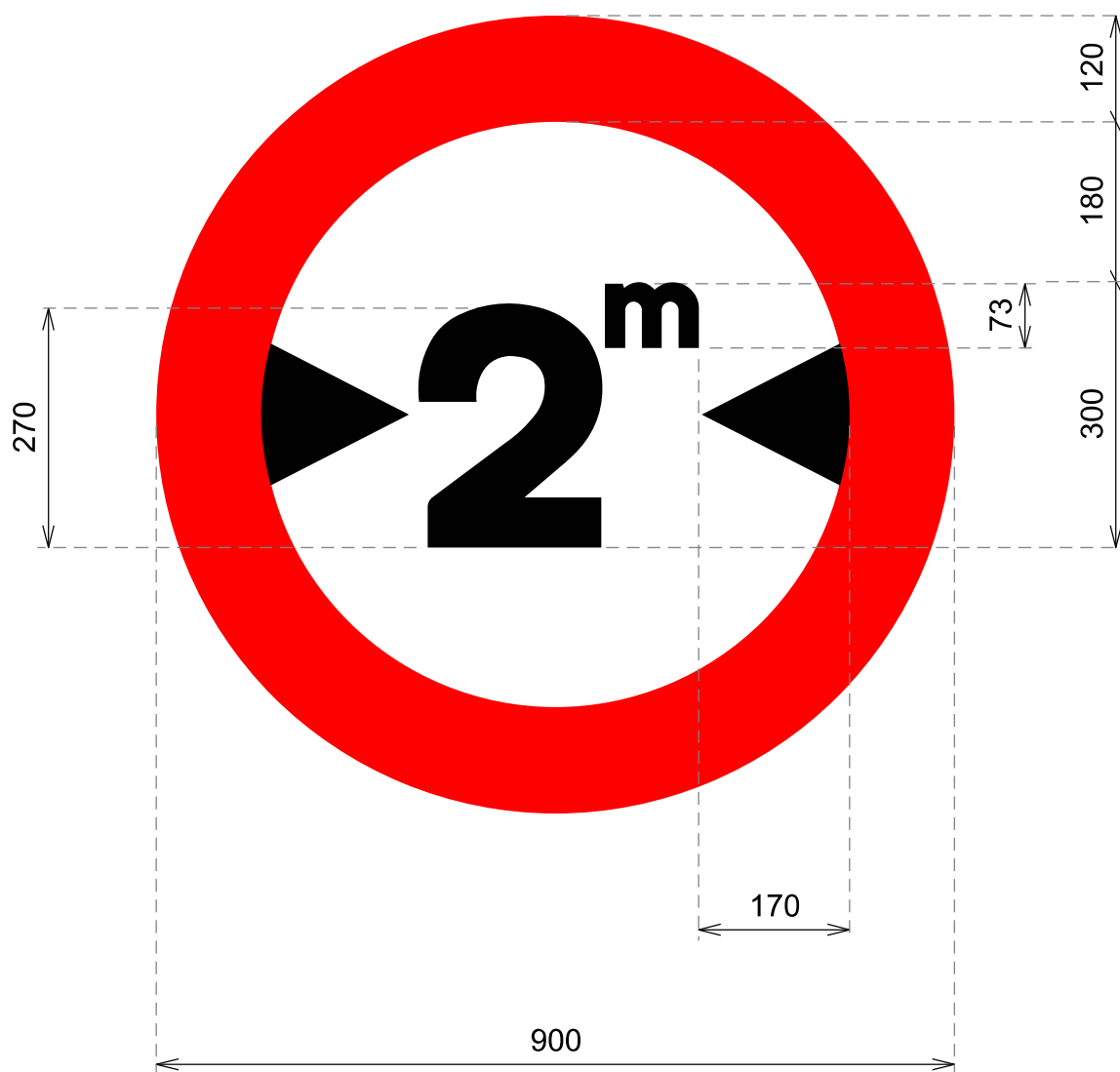

cotas en mm

Limitación de anchura

**R-204**

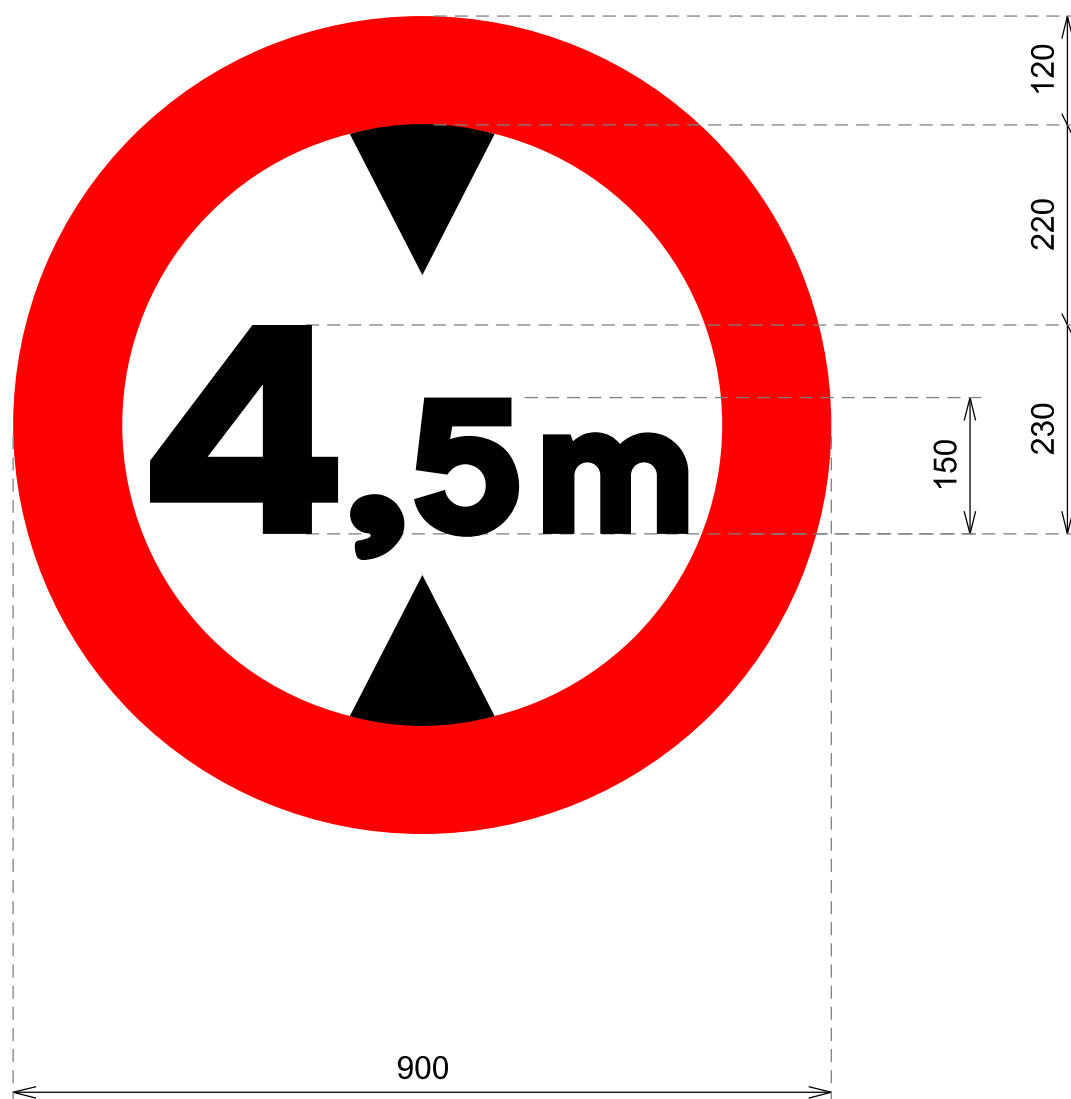

cotas en mm

Limitación de altura

**R-205**

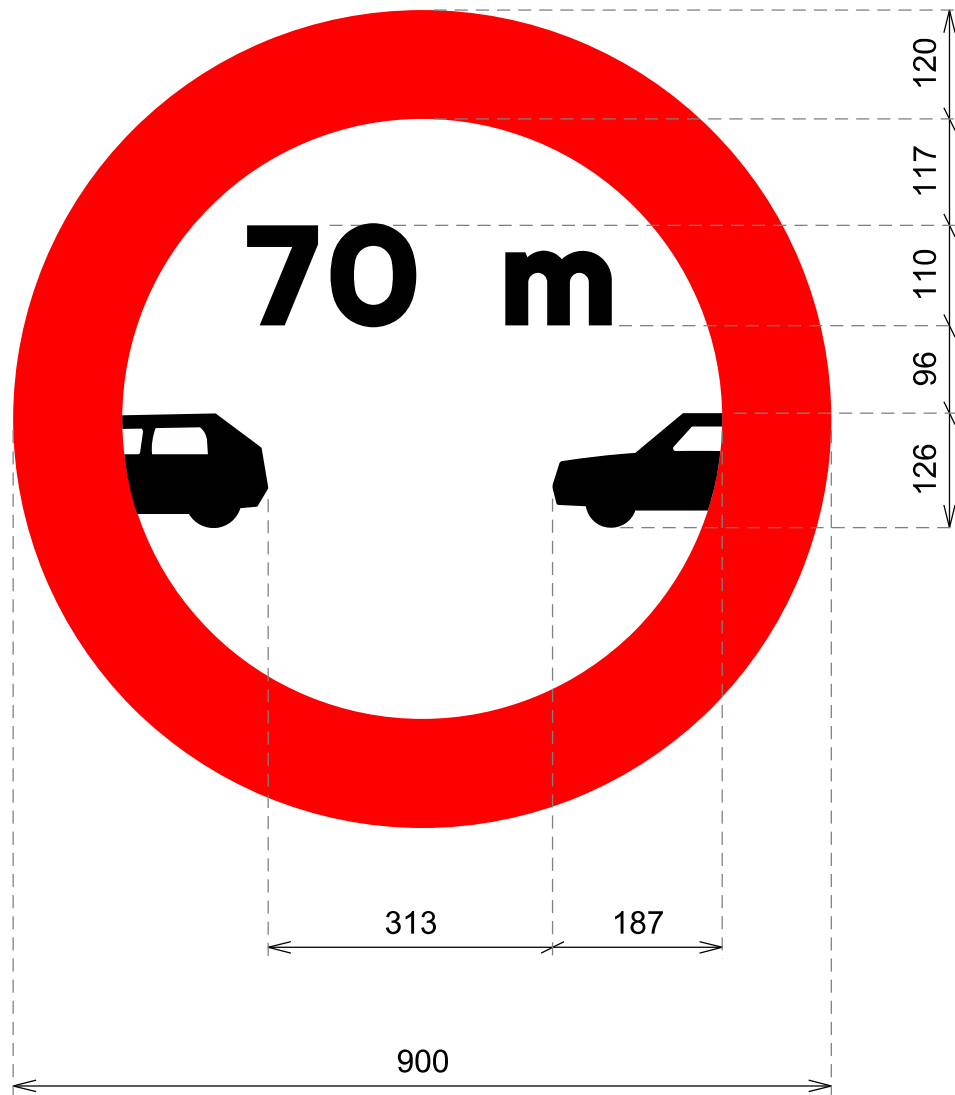

cotas en mm

Separación mínima

**R-300**



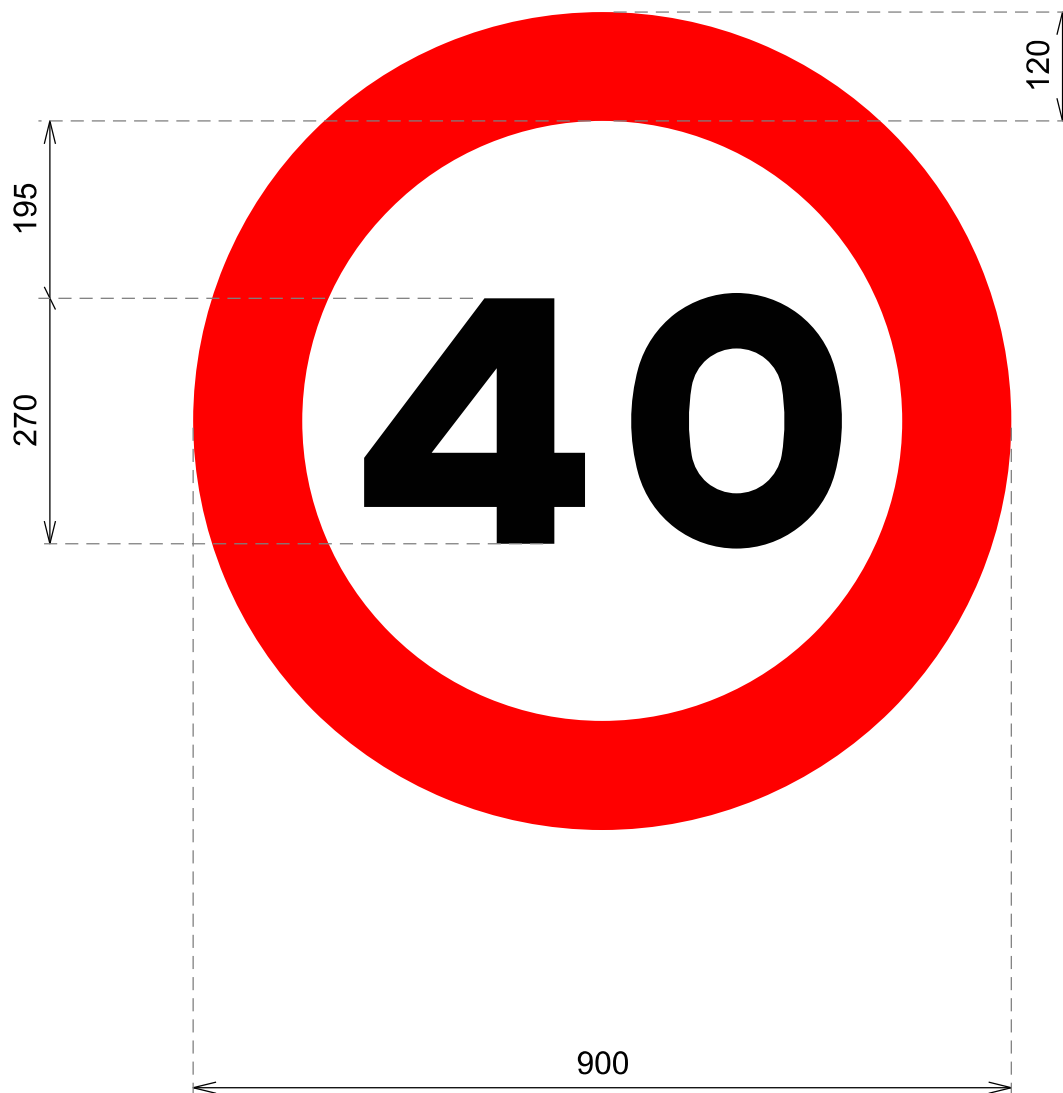

cotas en mm

Velocidad máxima

**R-301**

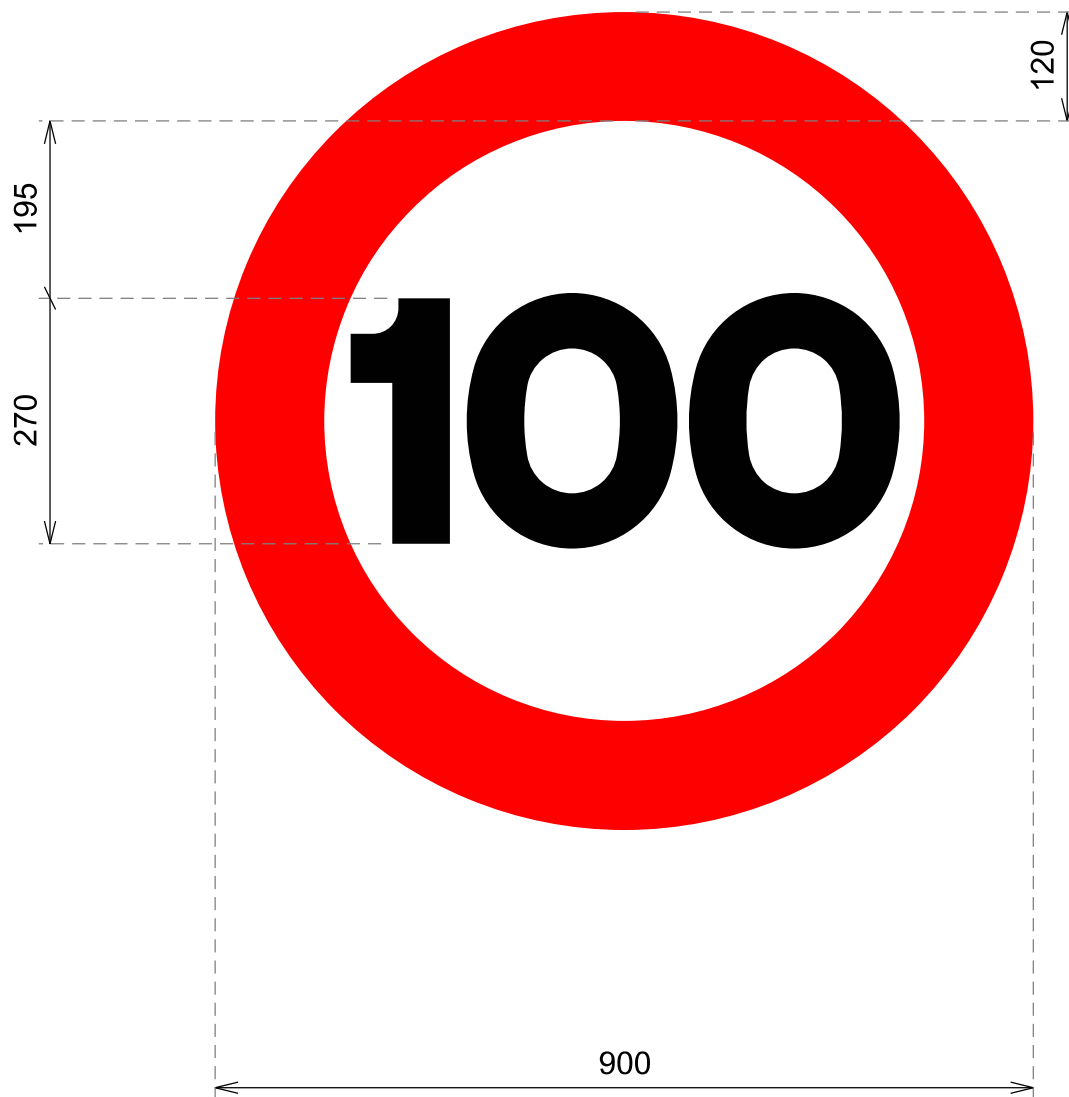

cotas en mm

Velocidad máxima

**R-301**

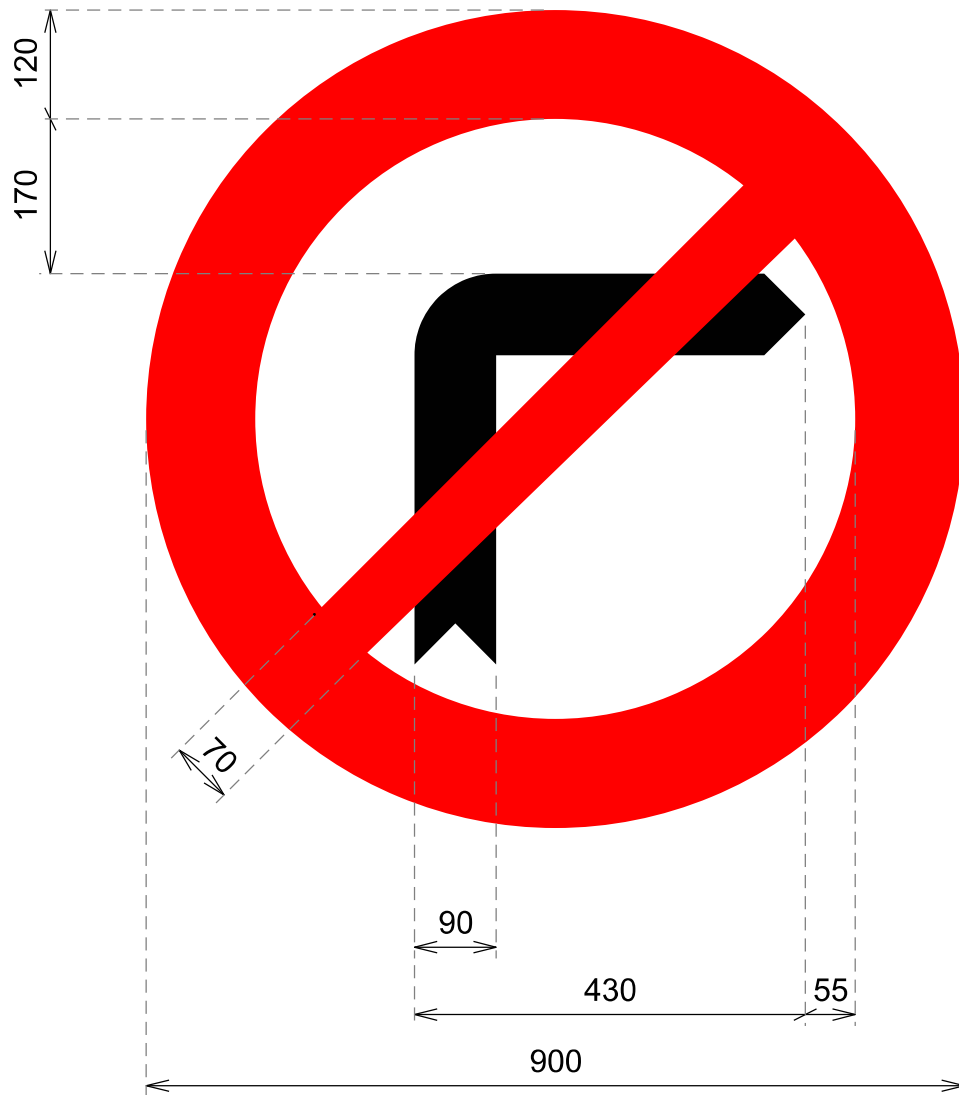

cotas en mm

Giro a la derecha prohibido

**R-302**



# SEÑALES DE REGLAMENTACIÓN

## OTRAS SEÑALES DE PROHIBICIÓN O RESTRICCIÓN

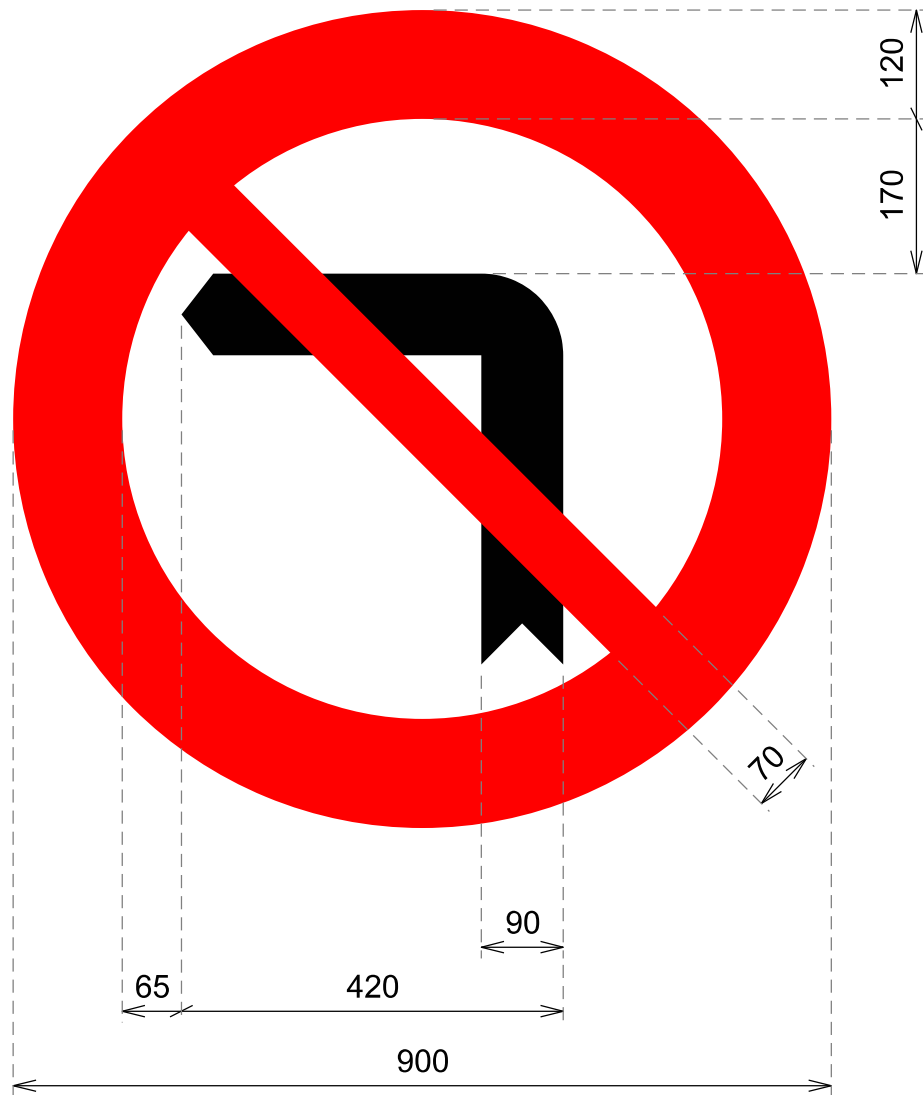

cotas en mm

Giro a la izquierda prohibido

**R-303**

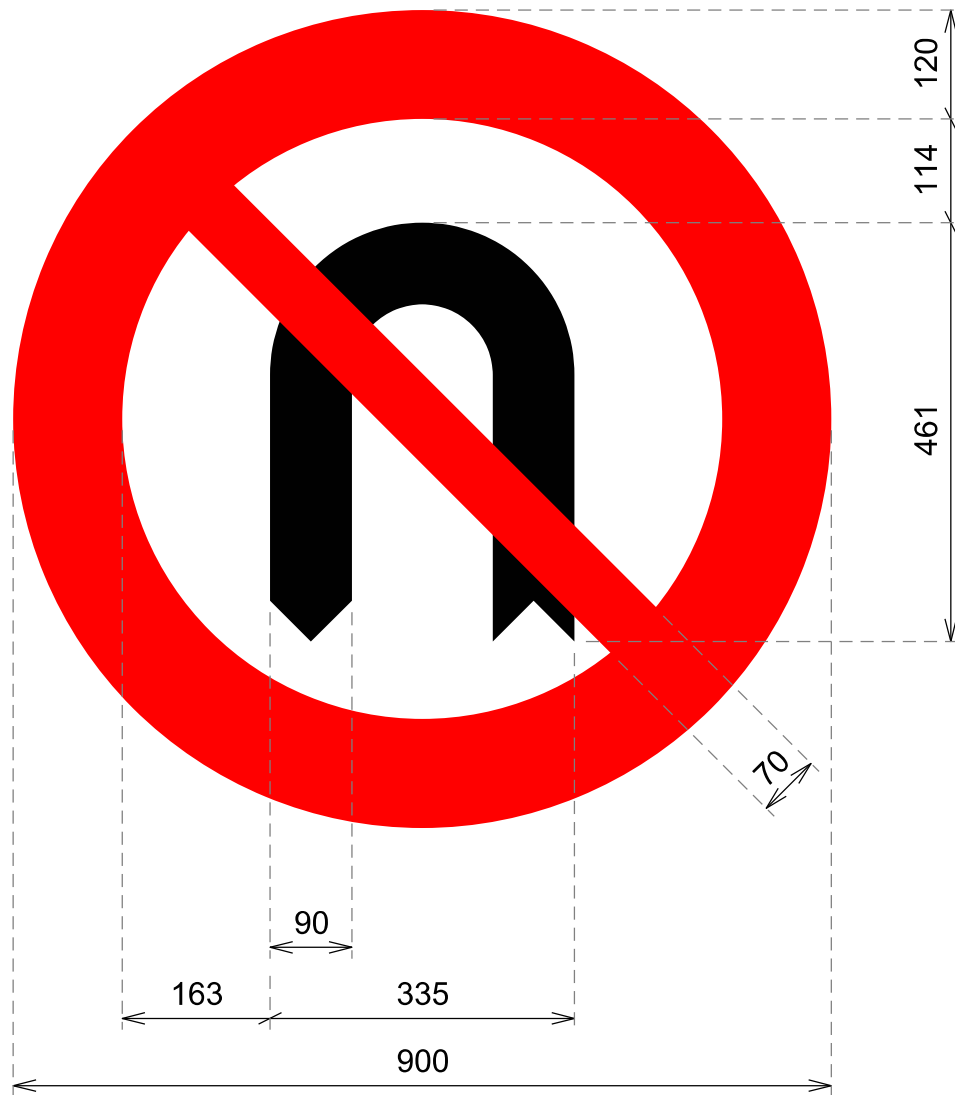

cotas en mm

Cambio de sentido prohibido

**R-304**



# SEÑALES DE REGLAMENTACIÓN

## OTRAS SEÑALES DE PROHIBICIÓN O RESTRICCIÓN

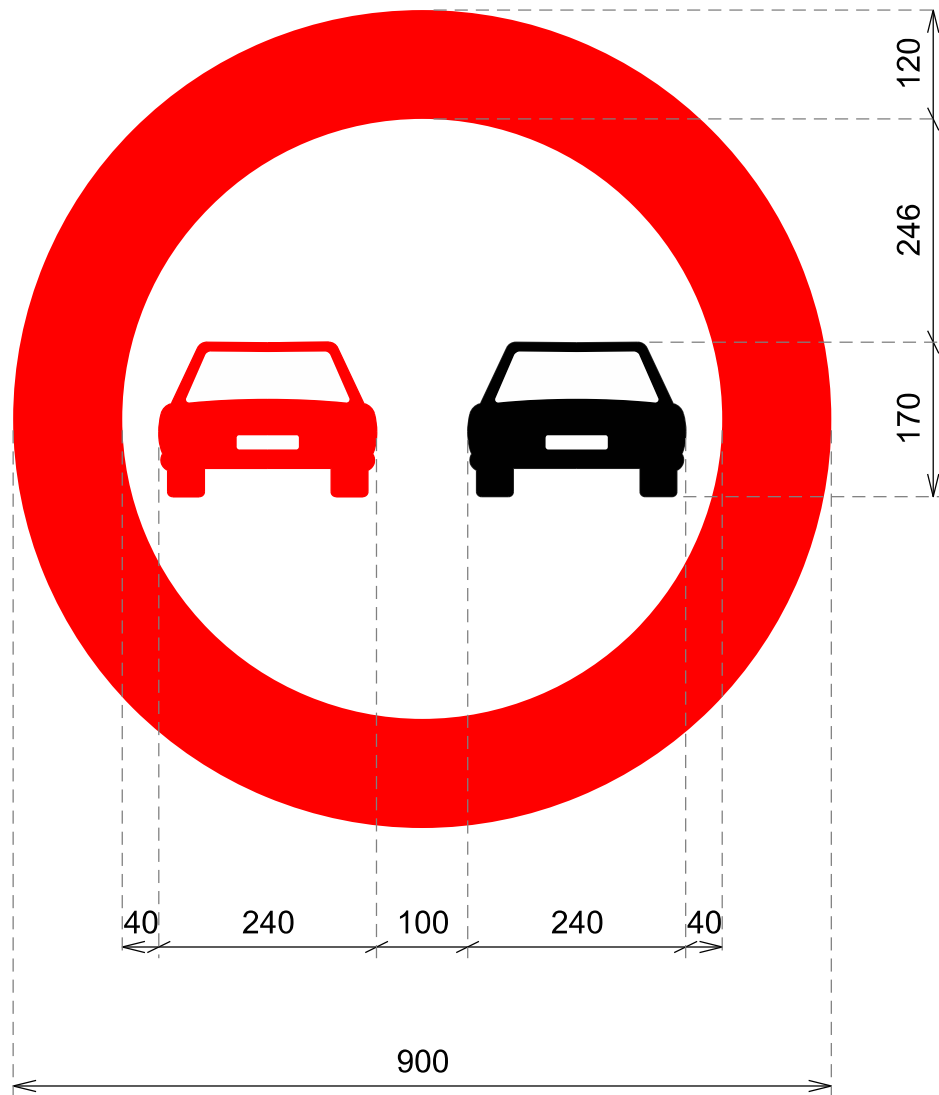

cotas en mm

Adelantamiento prohibido

**R-305**

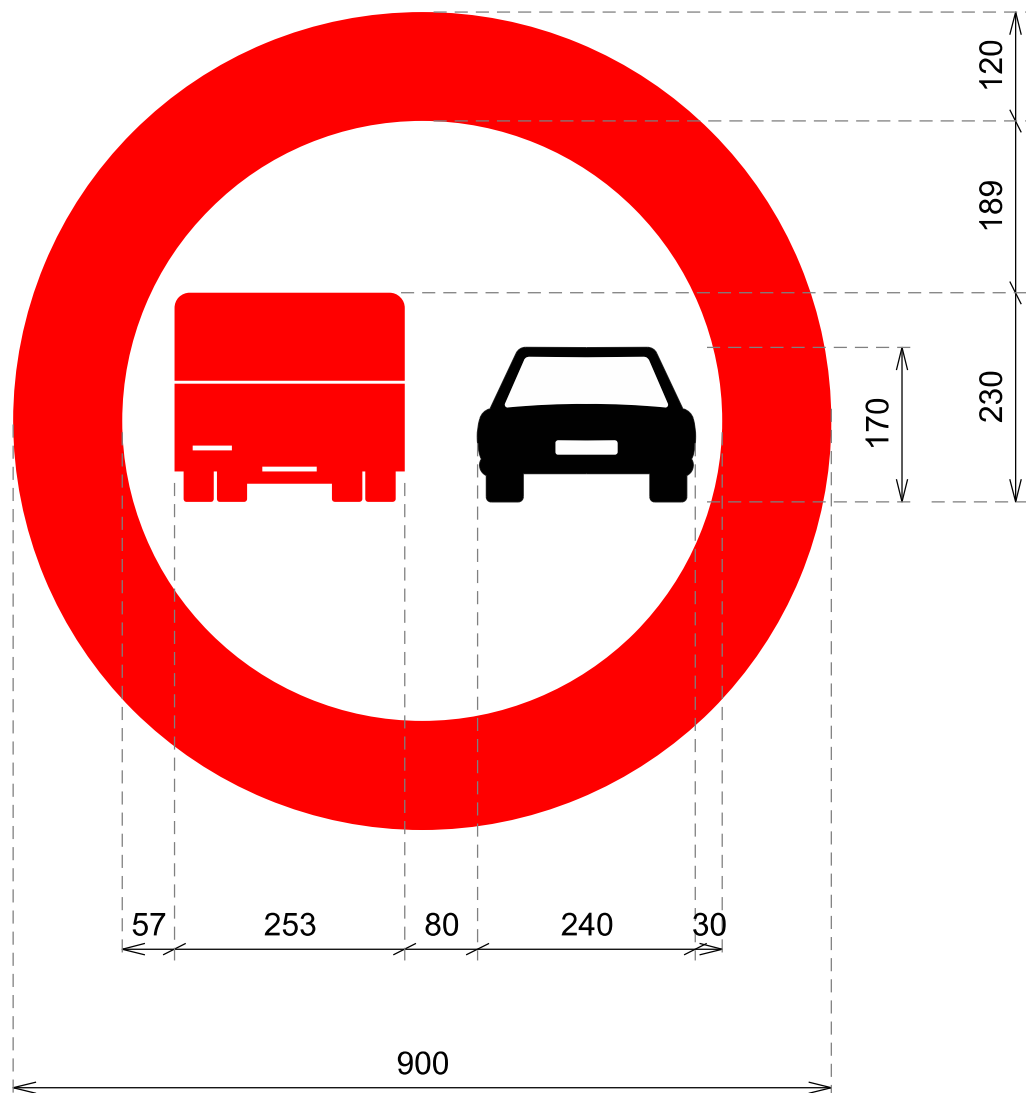

cotas en mm

Adelantamiento prohibido para camiones

**R-306**

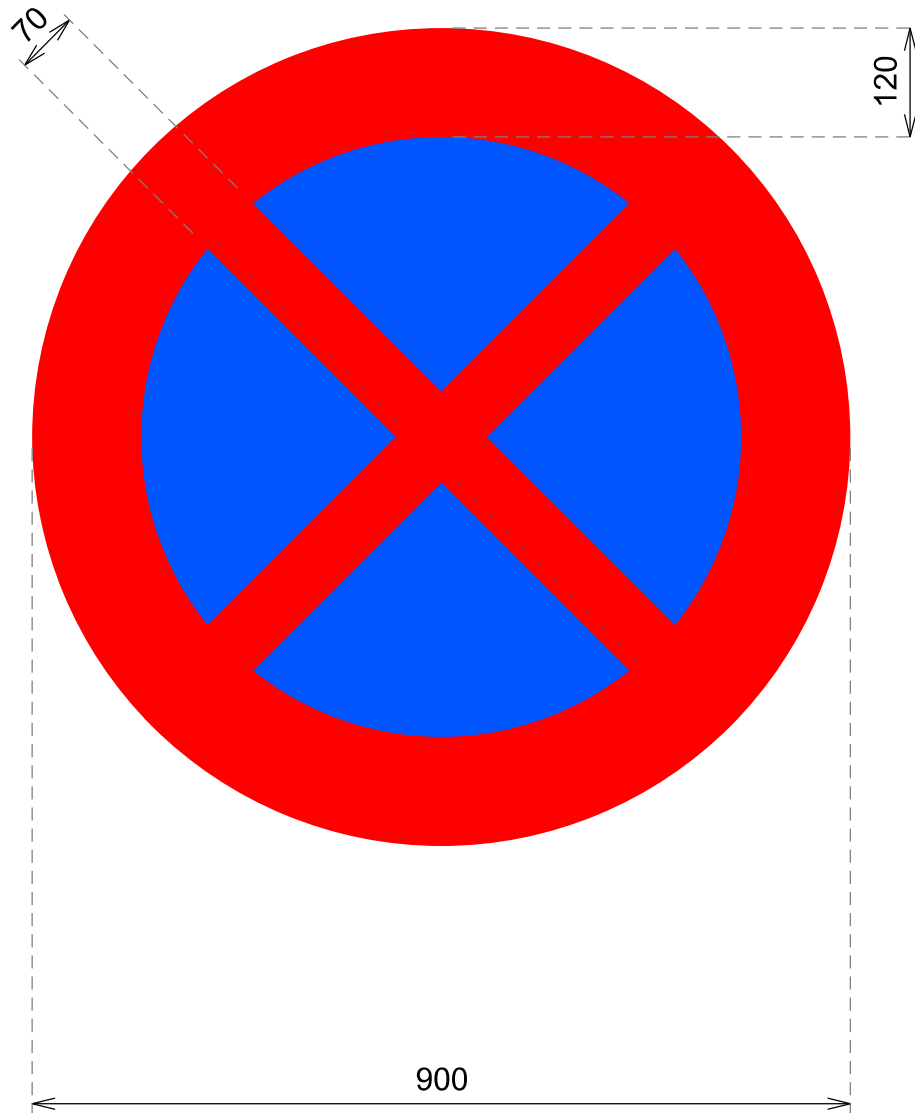

cotas en mm

Parada y estacionamiento prohibido

**R-307**



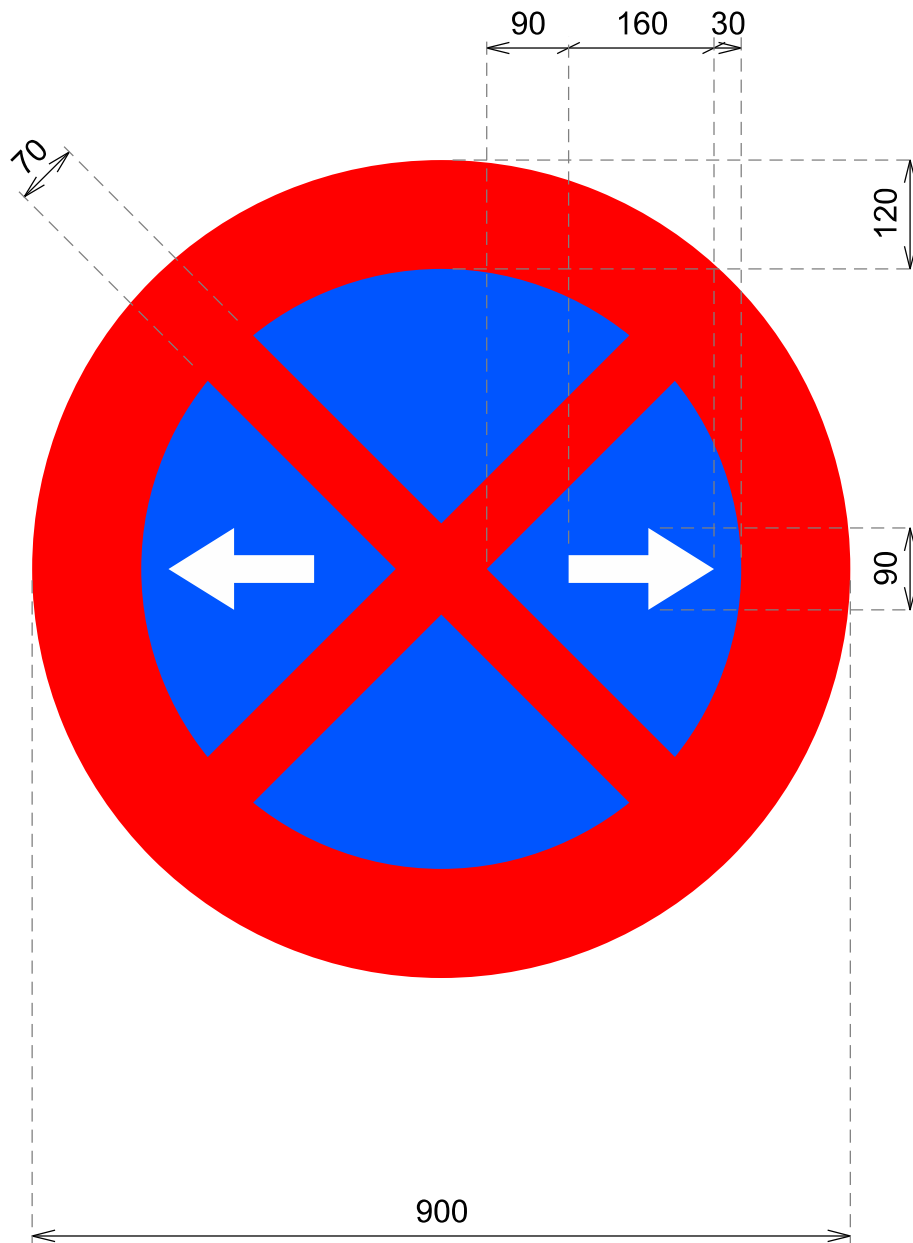

cotas en mm

Parada y estacionamiento prohibido hacia  
ambos lados de la señal

**R-307a**

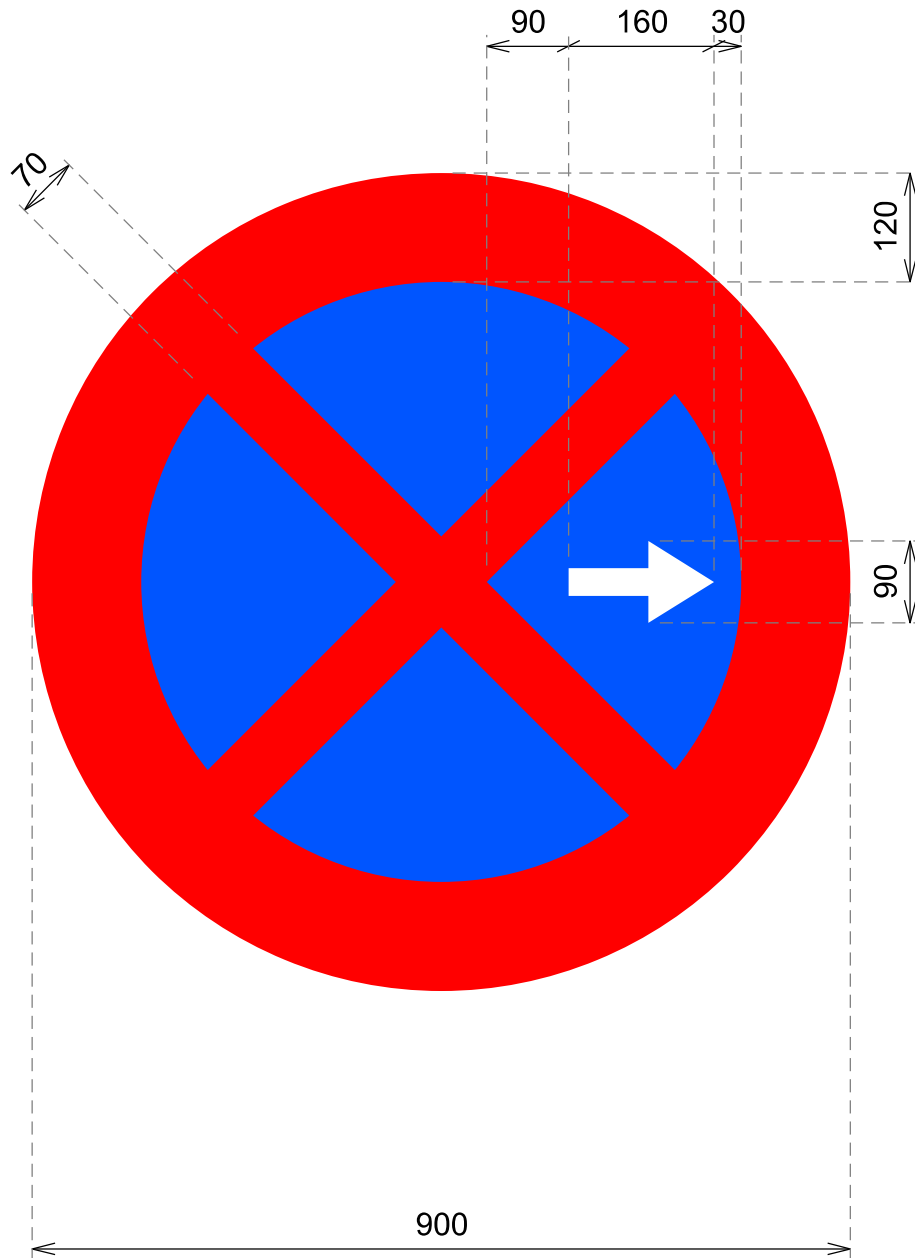

cotas en mm

Parada y estacionamiento prohibido hacia el lado de la señal indicado por la flecha

R-307b

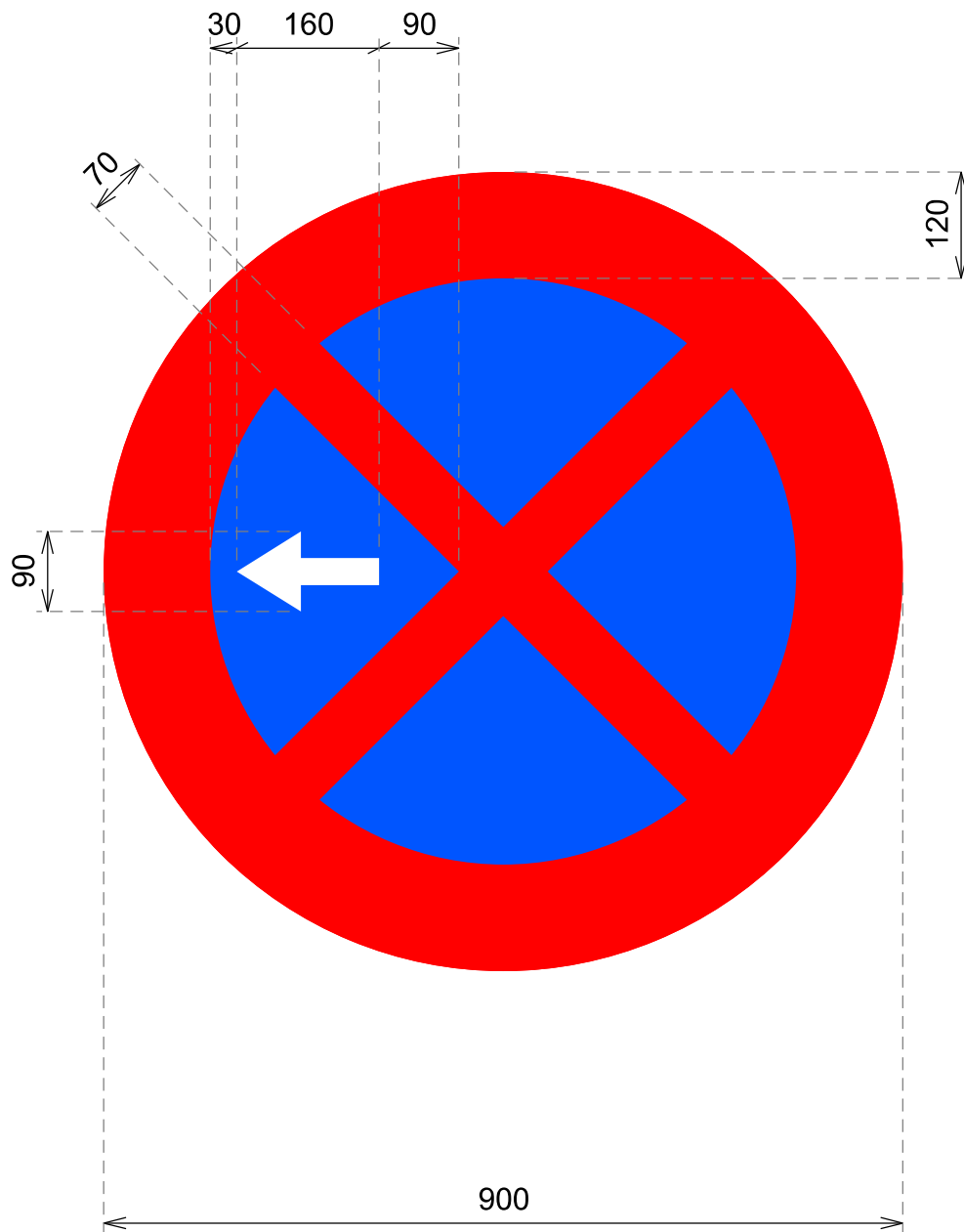

cotas en mm

Parada y estacionamiento prohibido hacia el lado de la señal indicado por la flecha

**R-307c**

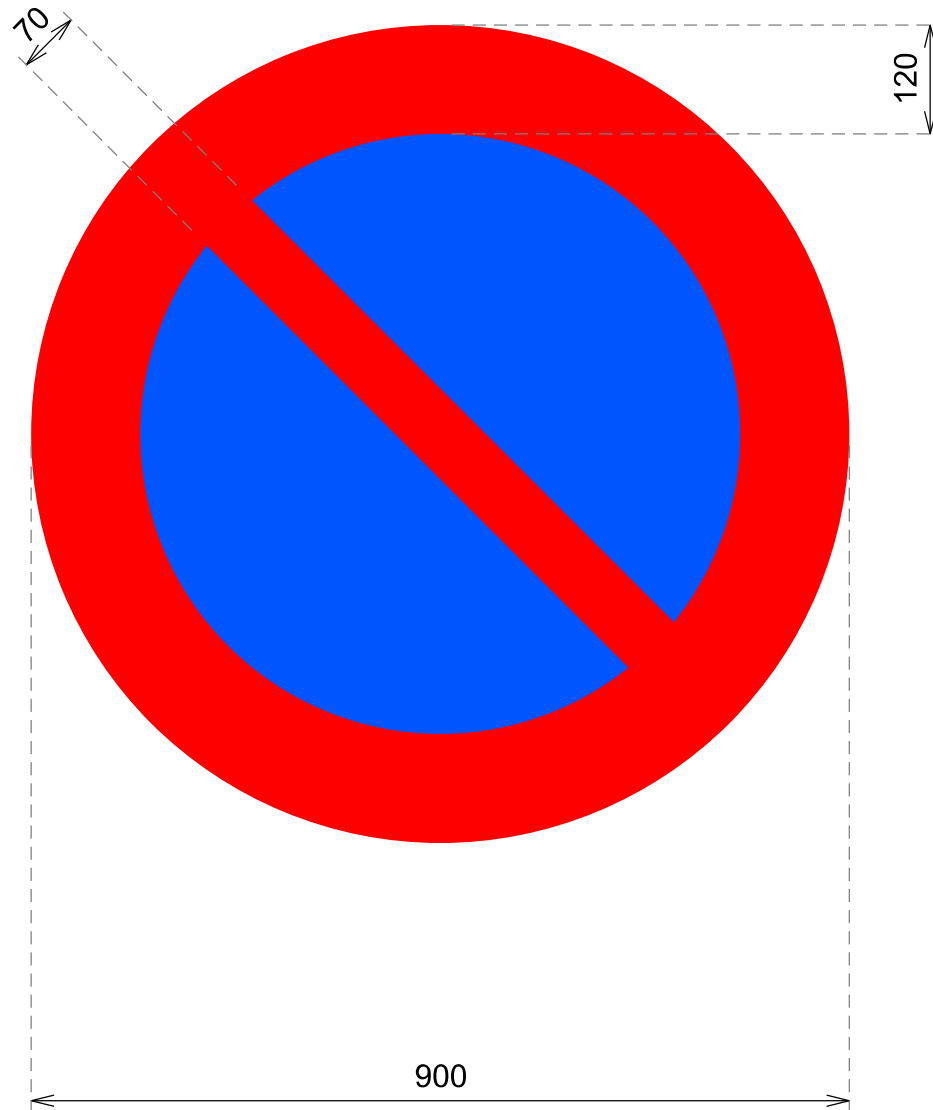

cotas en mm

Estacionamiento prohibido

**R-308**

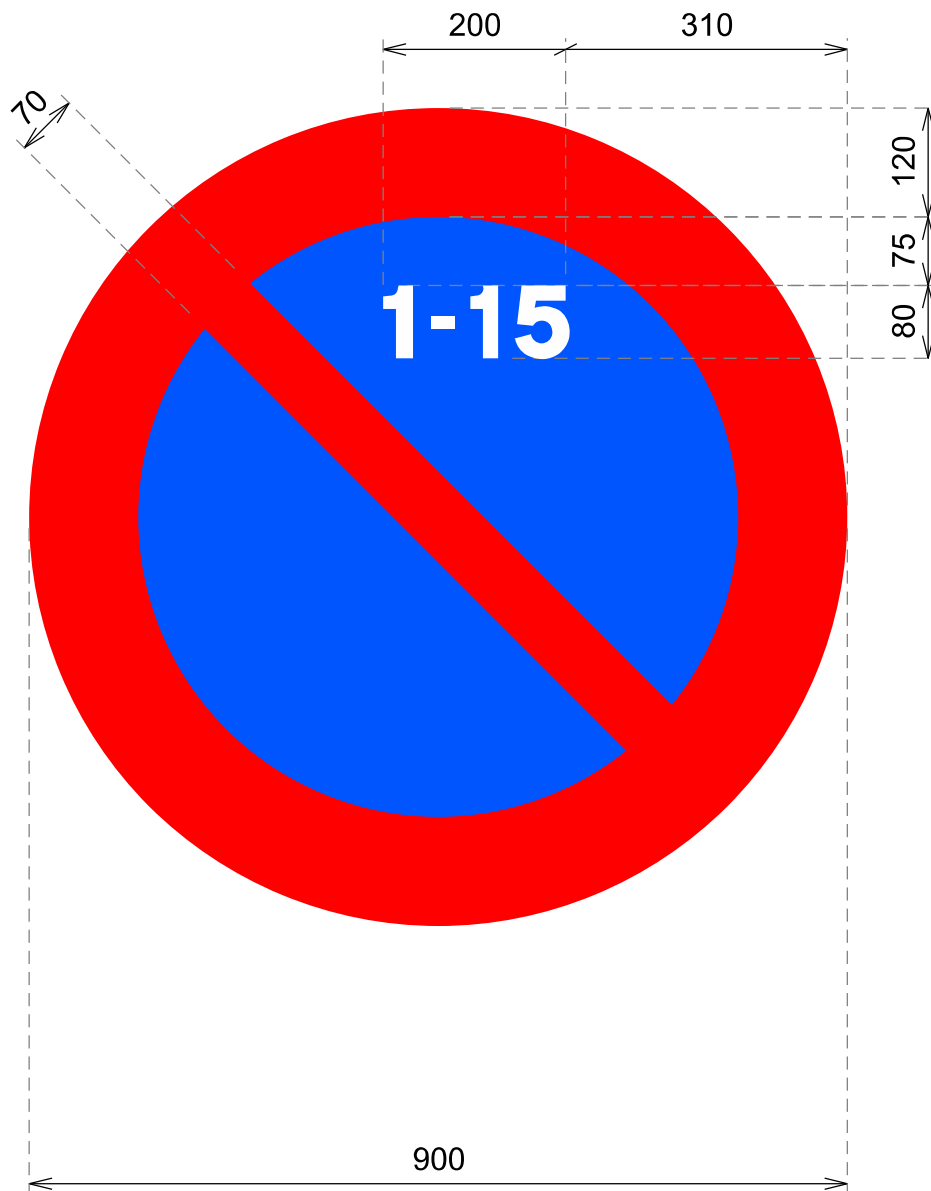

cotas en mm

Estacionamiento prohibido la primera quincena

**R-308c**

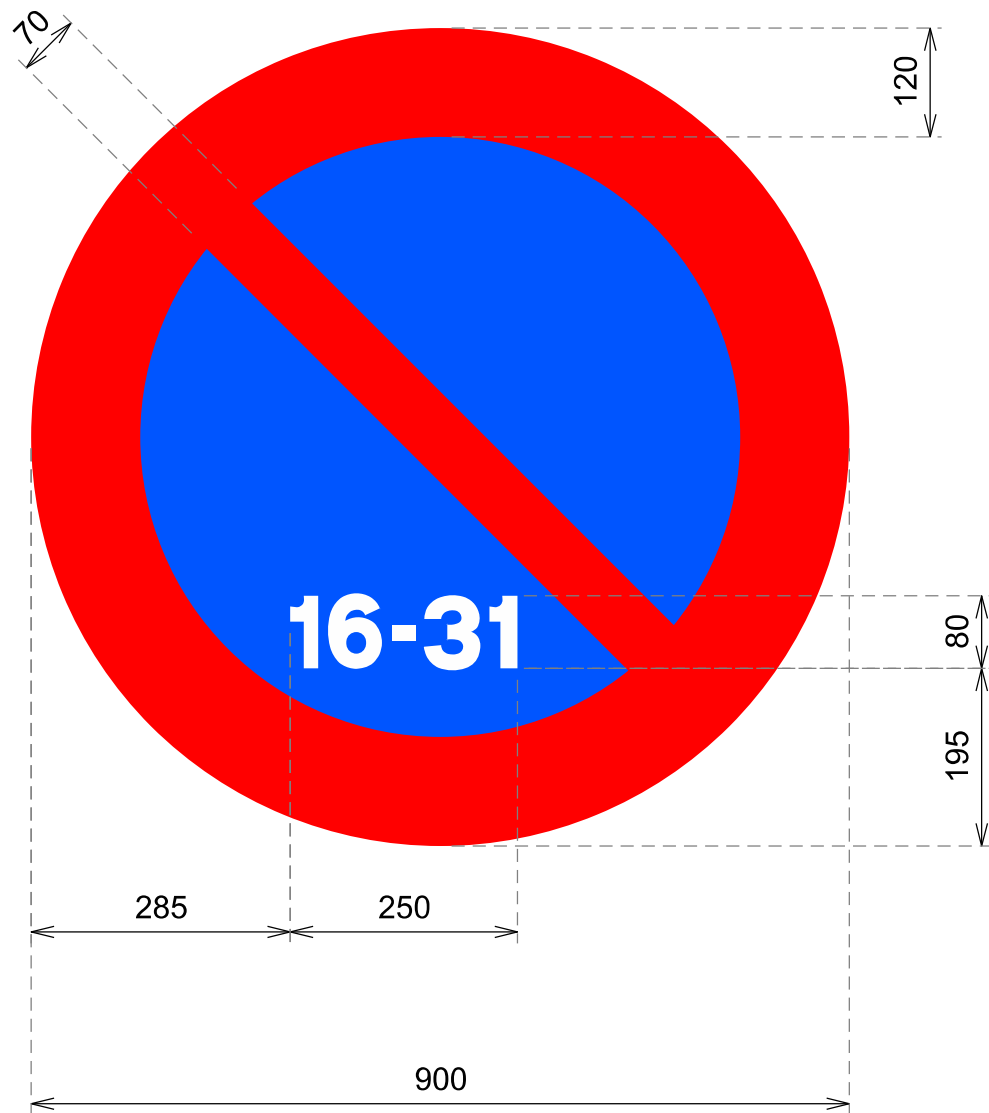

cotas en mm

Estacionamiento prohibido la segunda quincena

**R-308d**

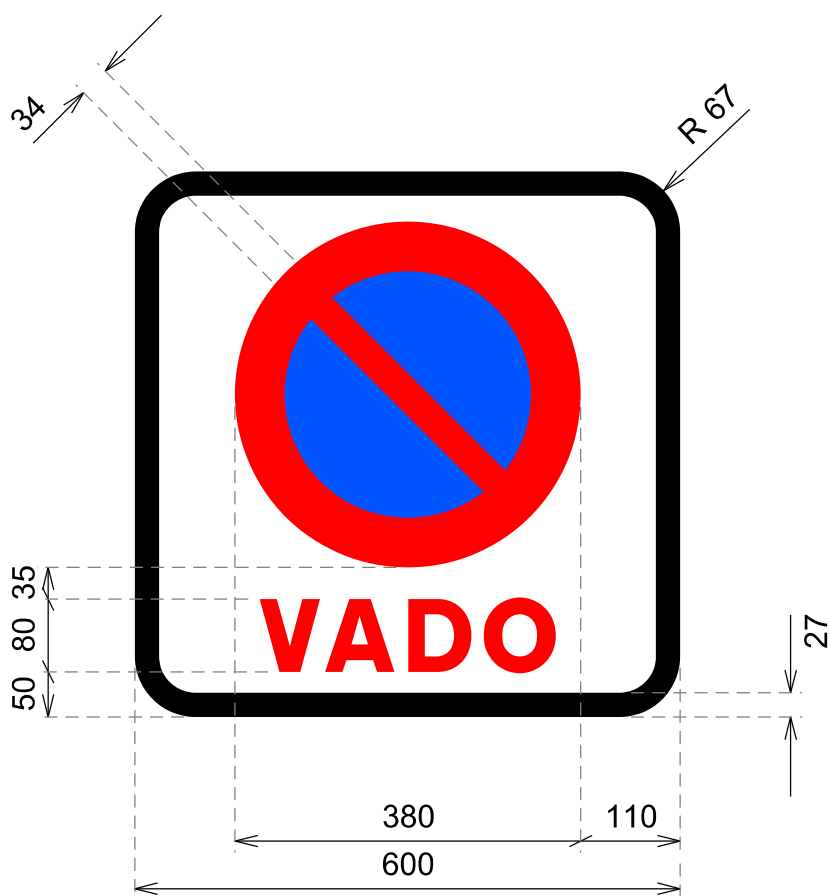

las dimensiones podrán variarse respetando las proporciones

cotas en mm

Estacionamiento prohibido en vado

R-308e



# SEÑALES DE REGLAMENTACIÓN

## OTRAS SEÑALES DE PROHIBICIÓN O RESTRICCIÓN

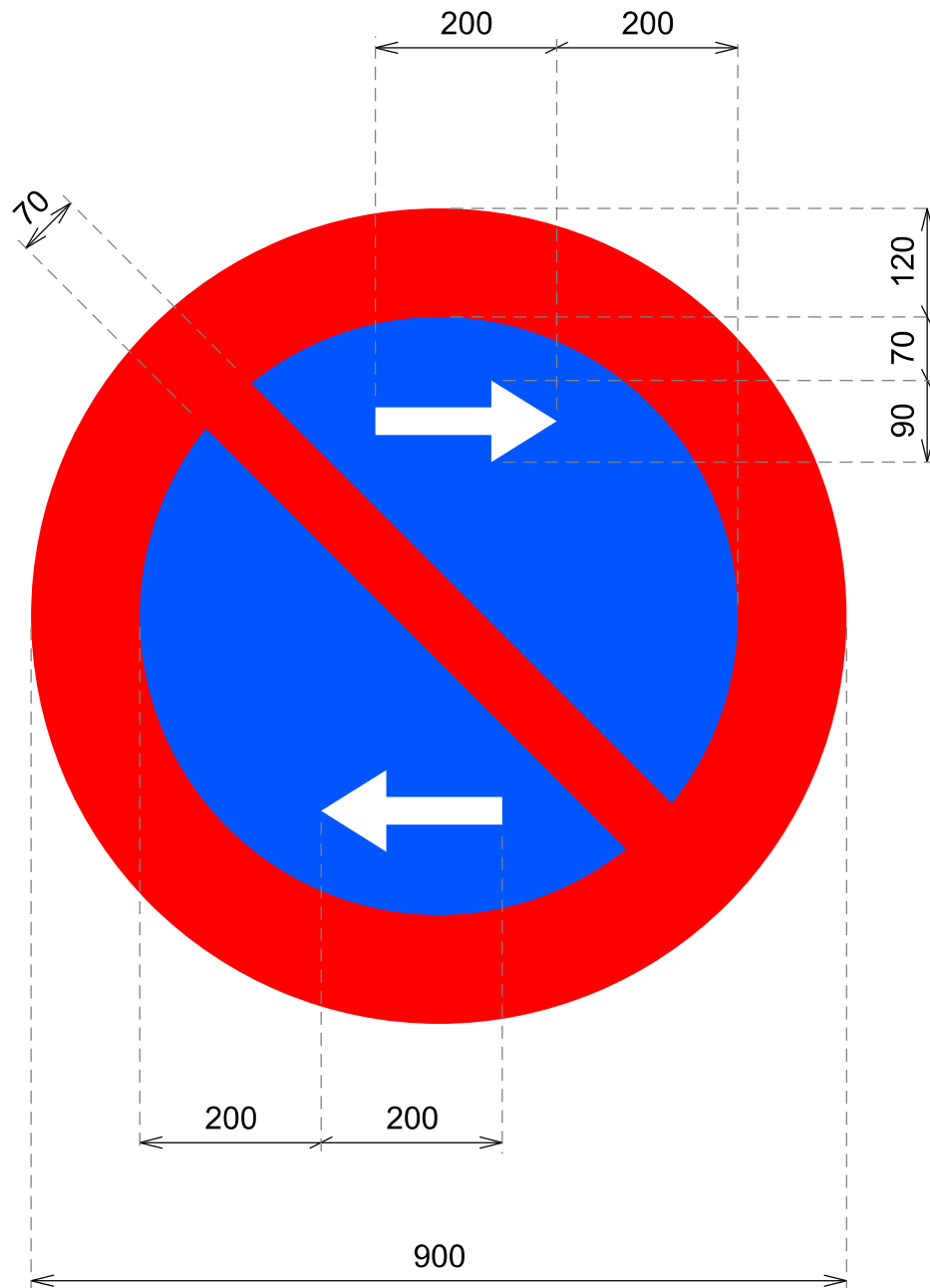

cotas en mm

Estacionamiento prohibido hacia ambos lados de la señal

**R-308f**



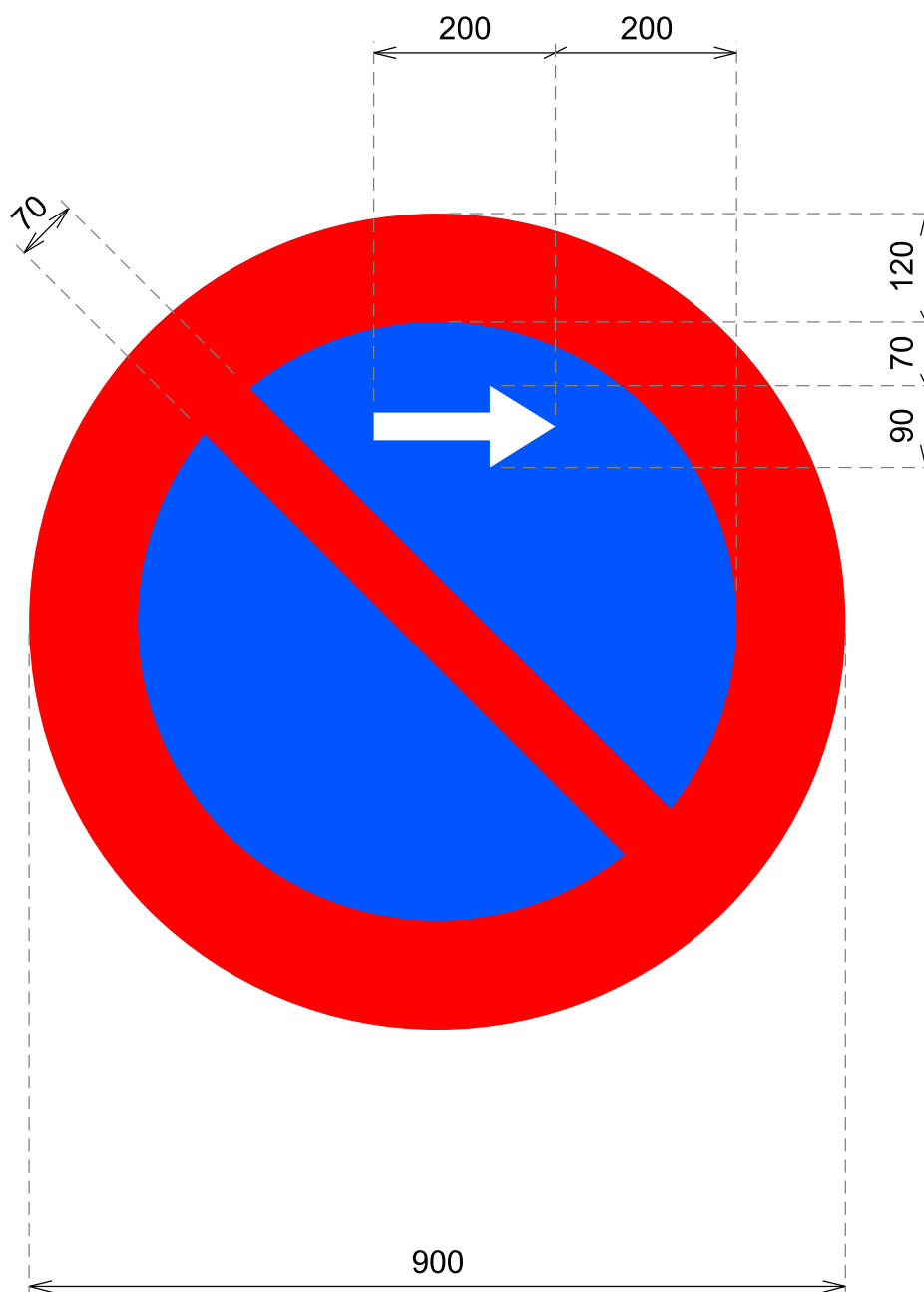

cotas en mm

Estacionamiento prohibido hacia el lado  
de la señal indicado por la flecha

**R-308g**

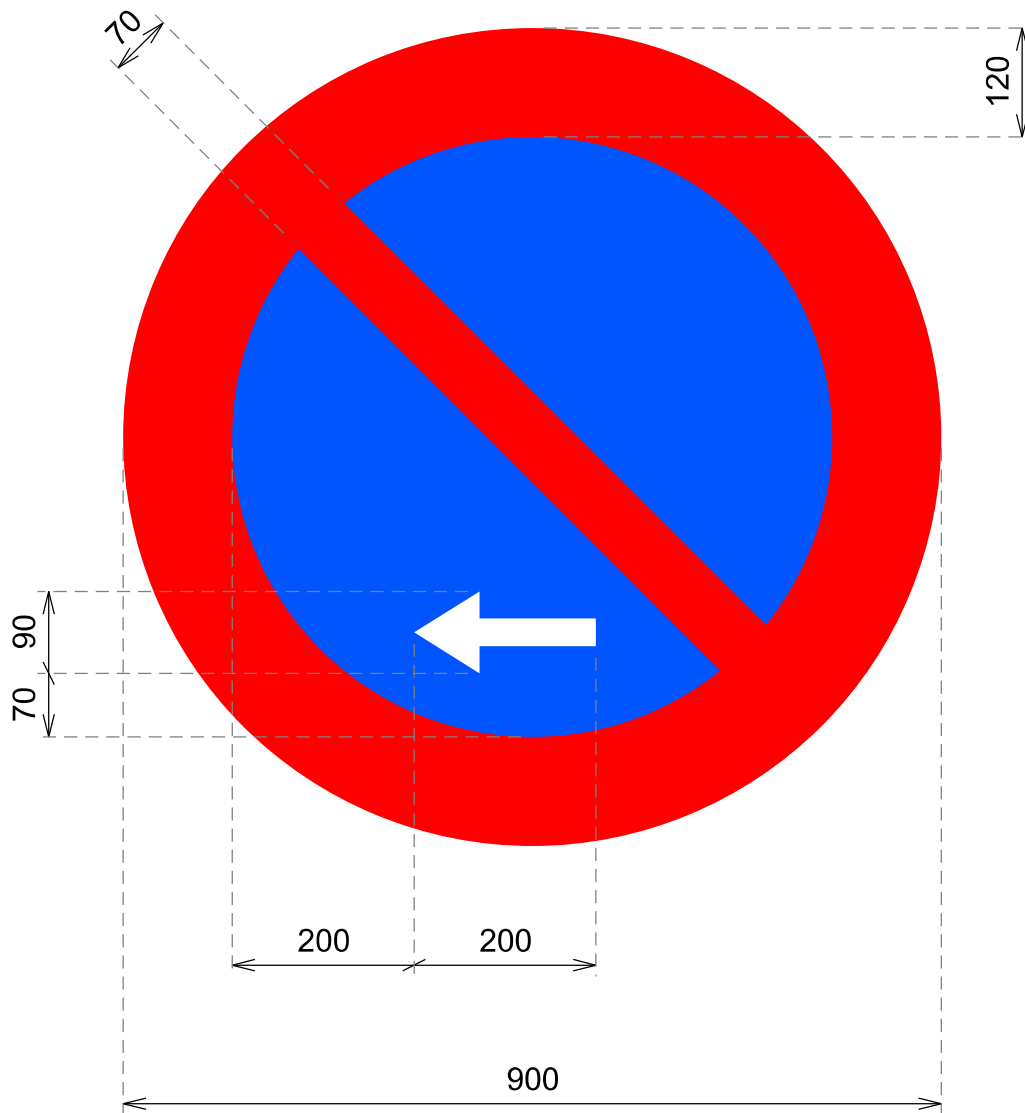

cotas en mm

Estacionamiento prohibido hacia el lado  
de la señal indicado por la flecha

**R-308h**

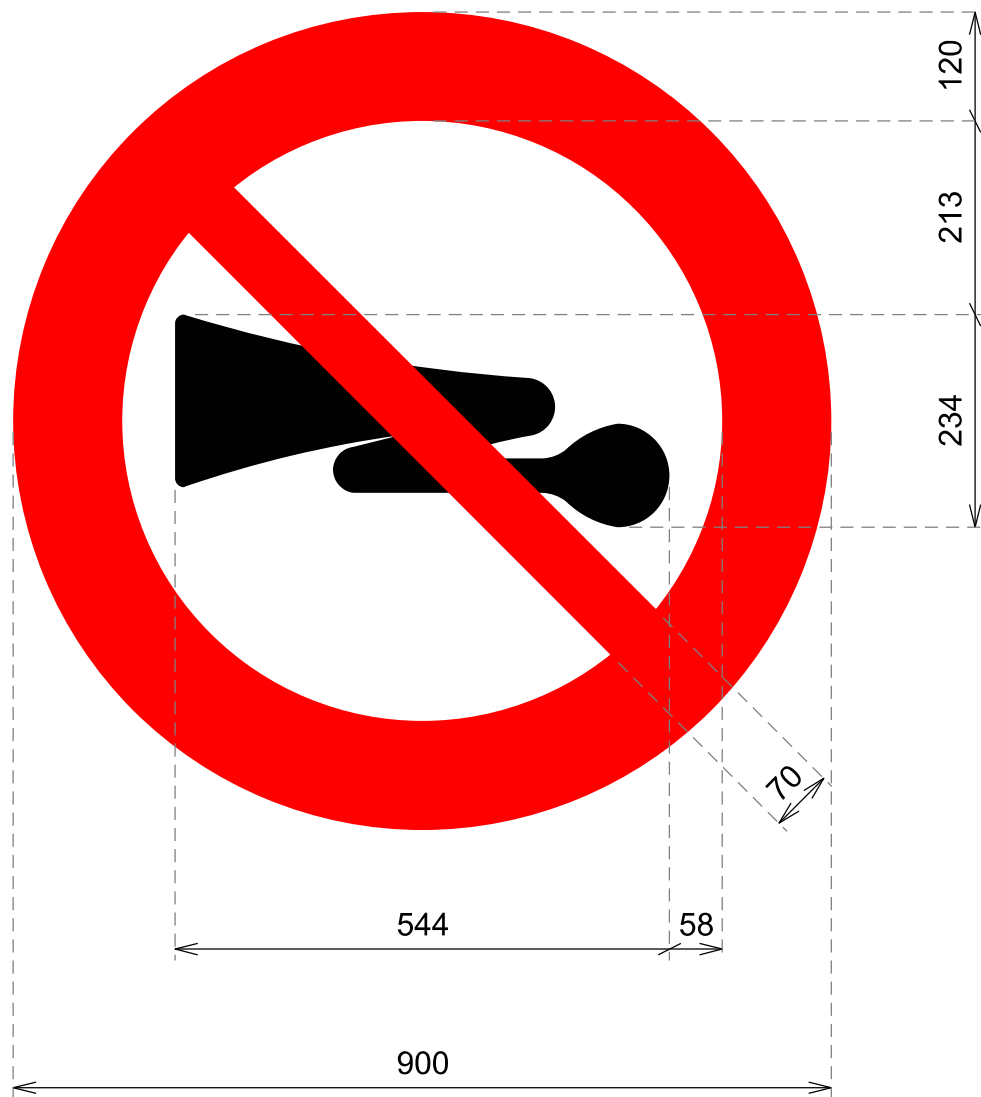

cotas en mm

Advertencias acústicas prohibidas

**R-310**

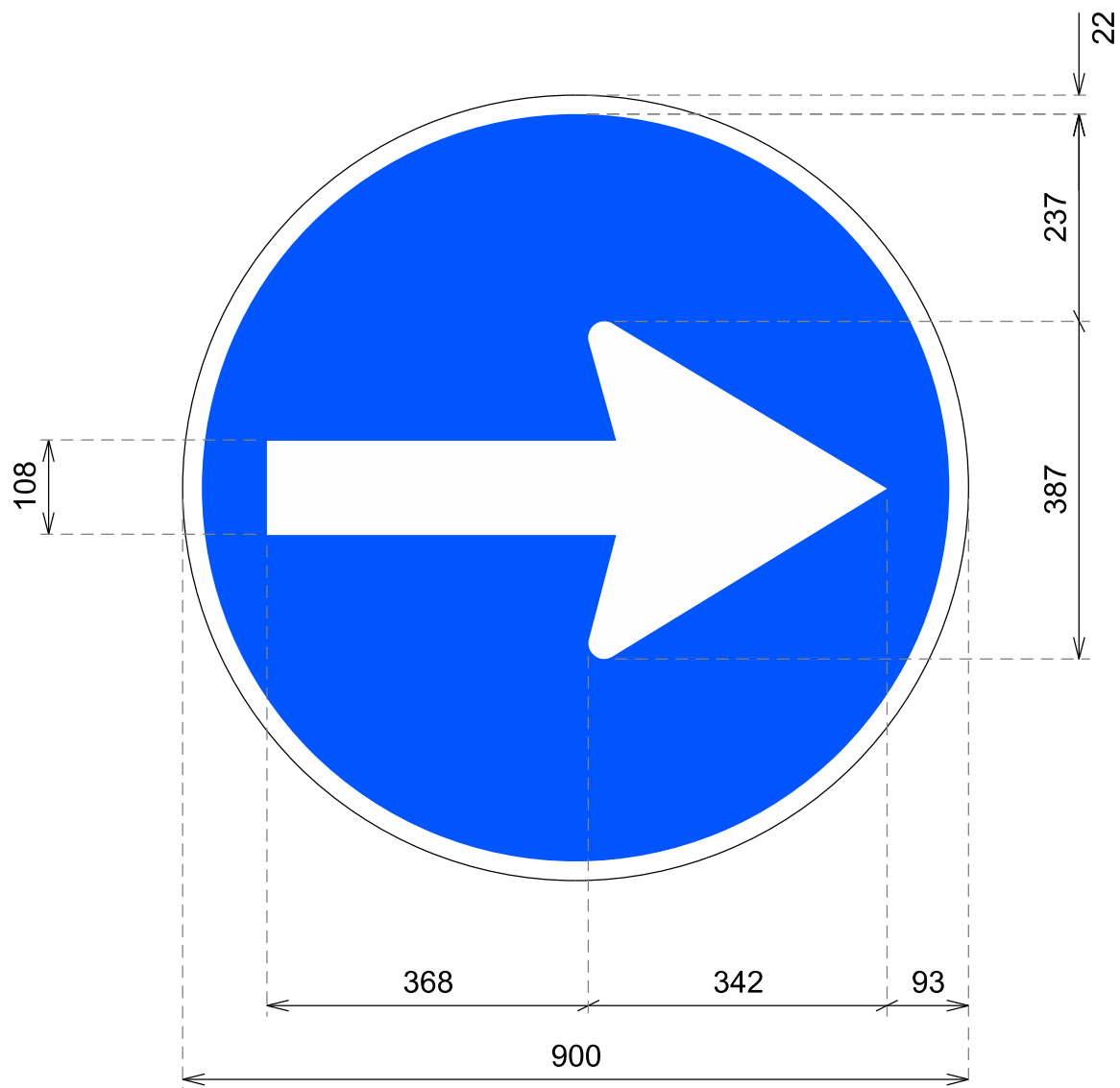

cotas en mm

Sentido obligatorio

R-400a

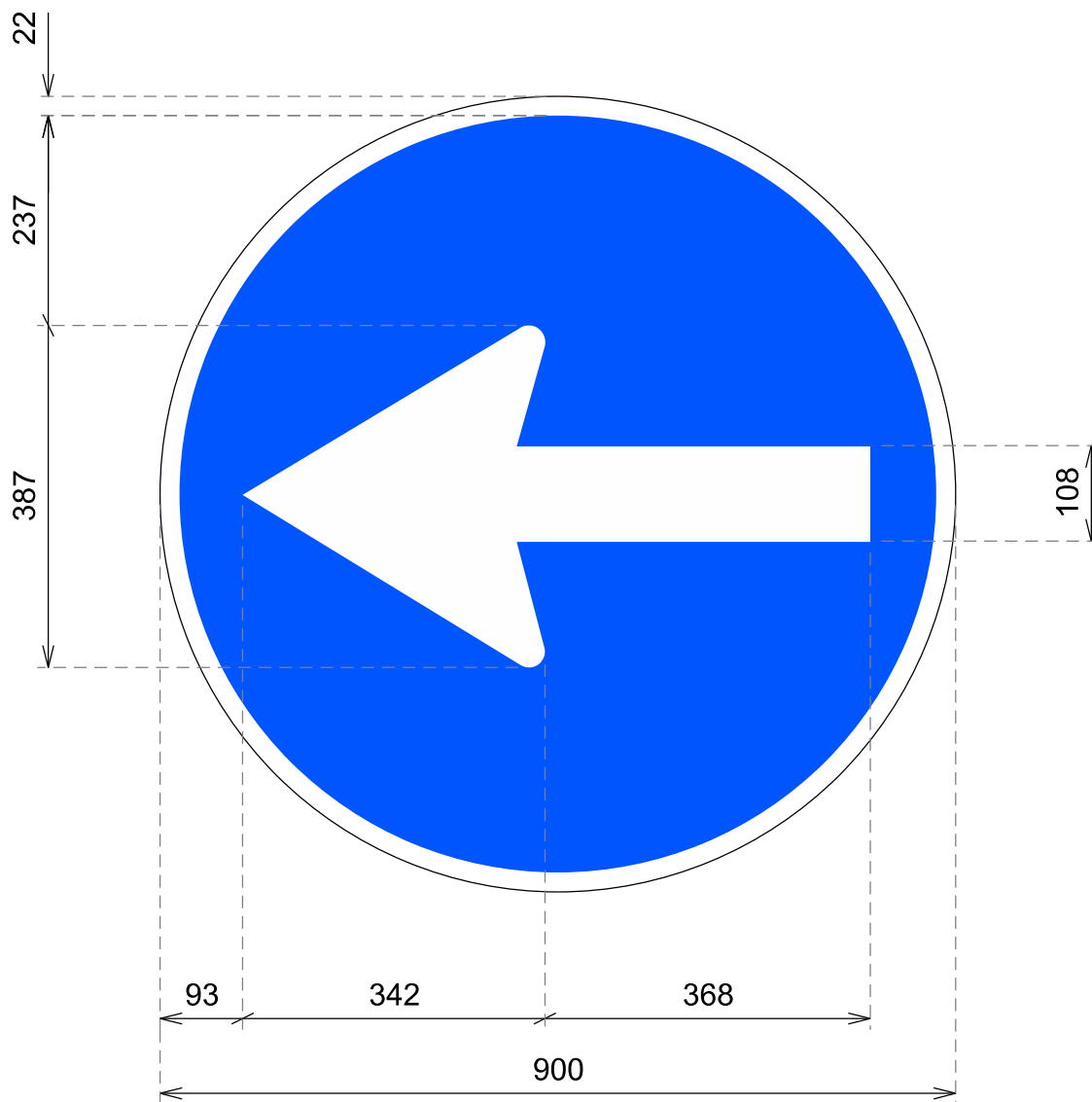

cotas en mm

Sentido obligatorio

R-400b

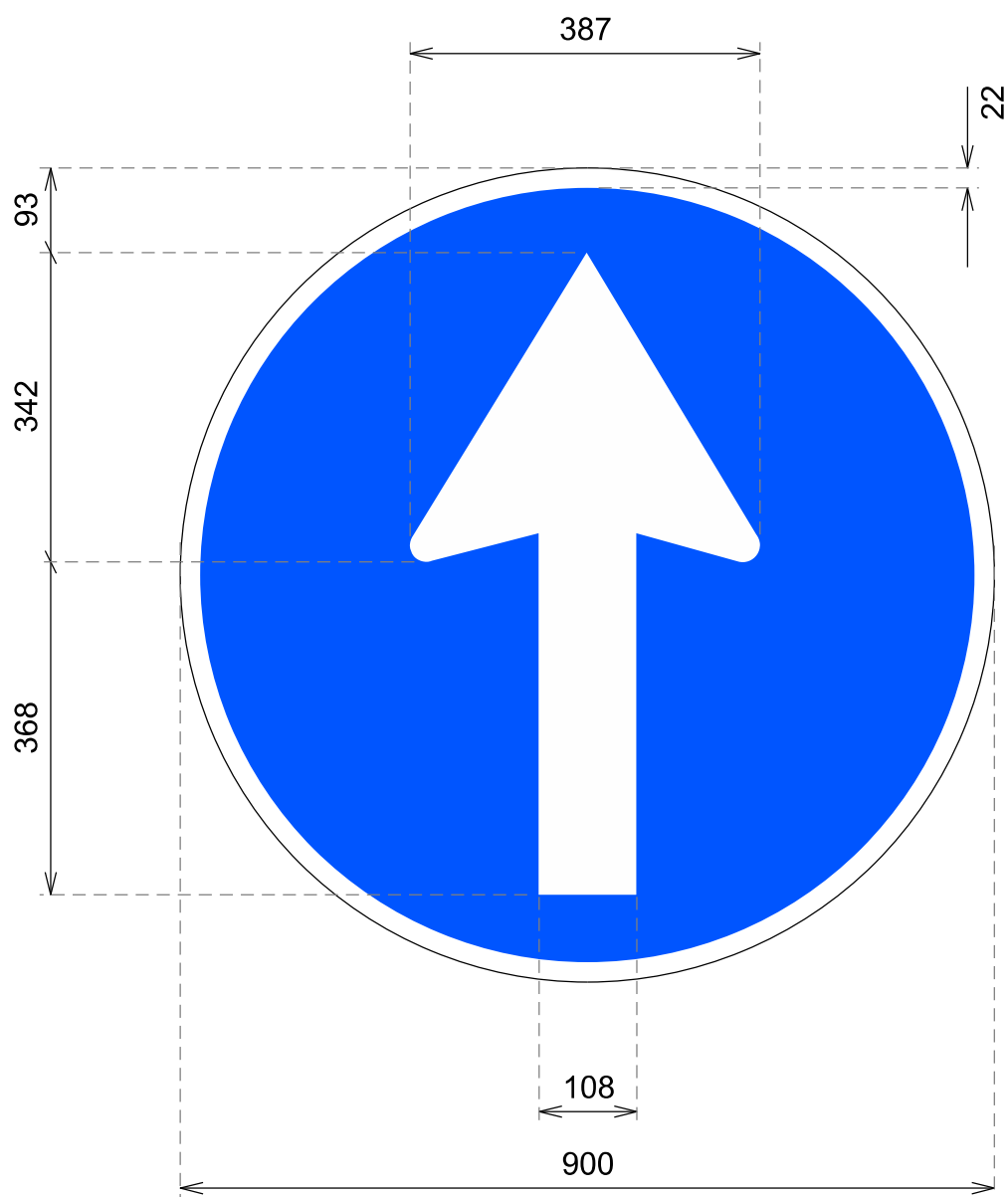

cotas en mm

Sentido obligatorio

R-400c

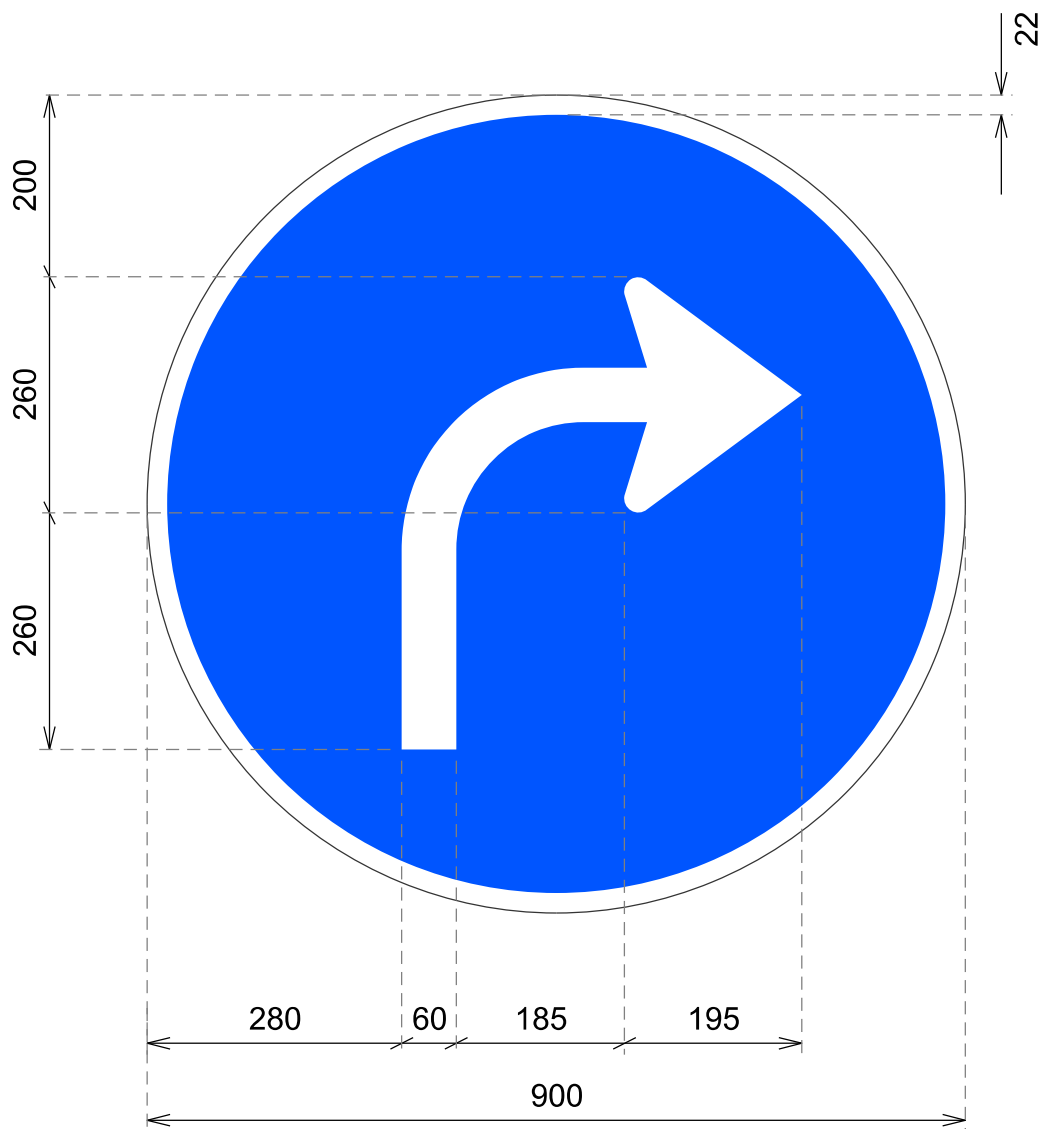

cotas en mm

Sentido obligatorio

R-400d

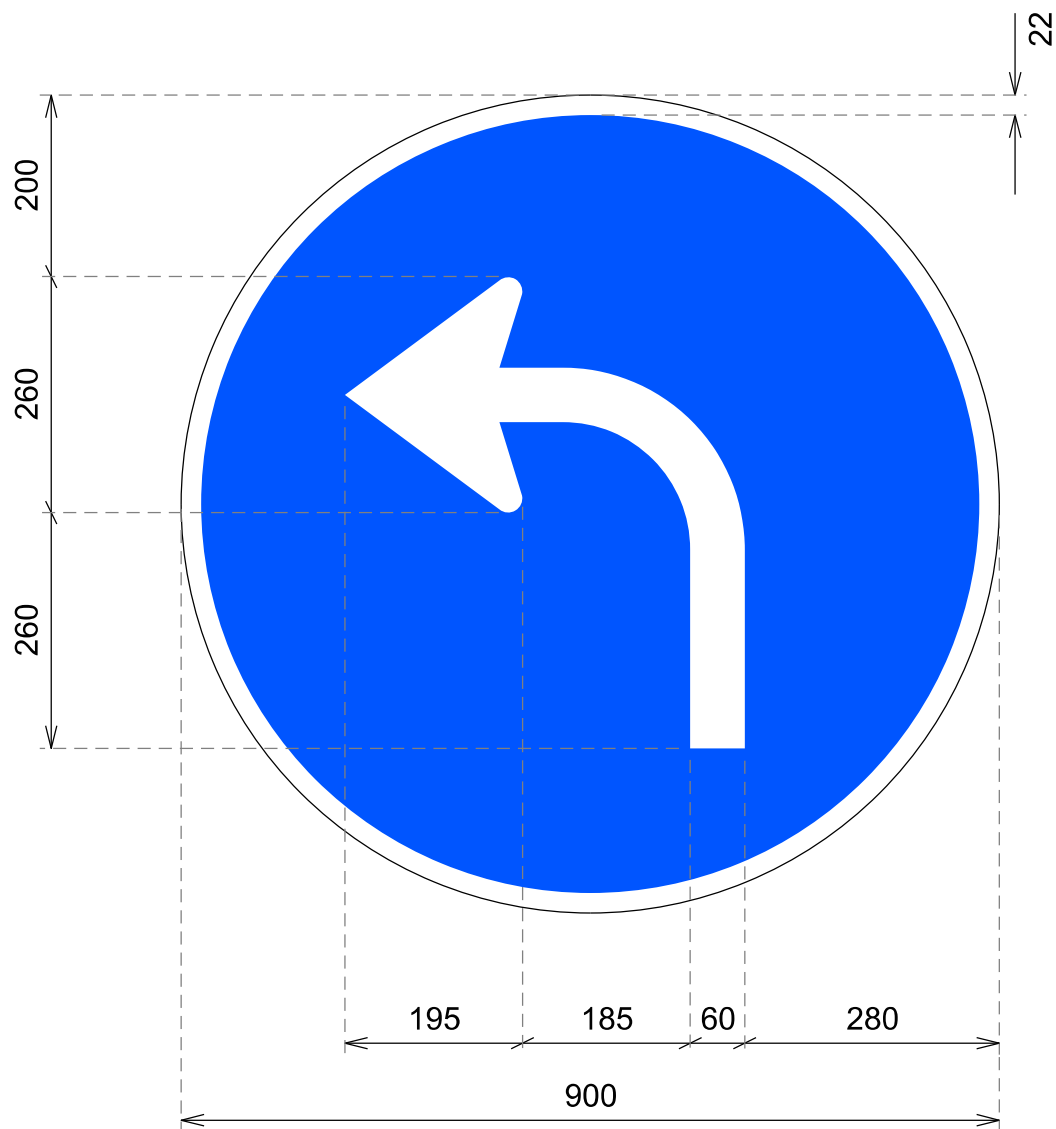

cotas en mm

Sentido obligatorio

R-400e



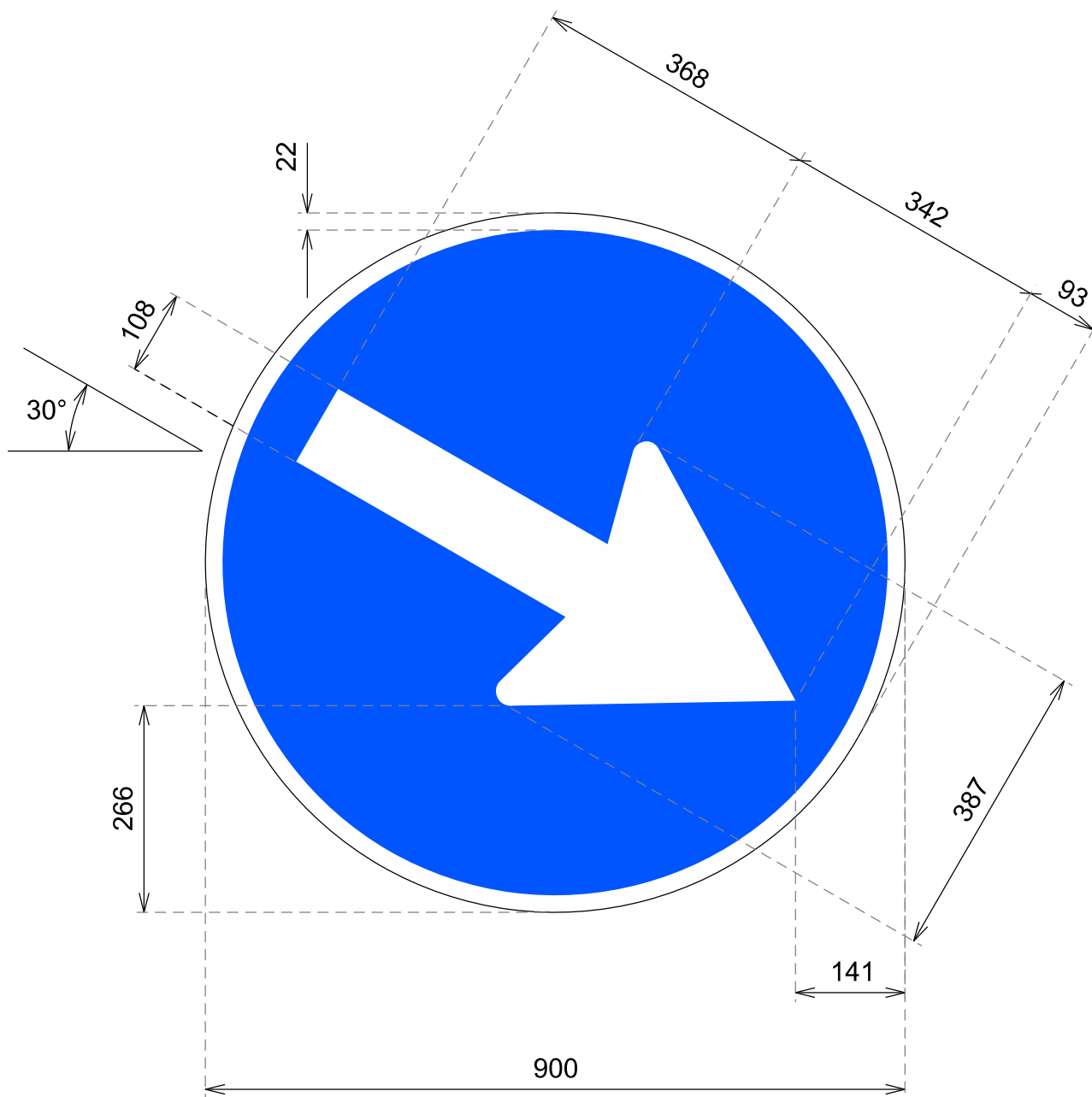

cotas en mm

Paso obligatorio

R-401a

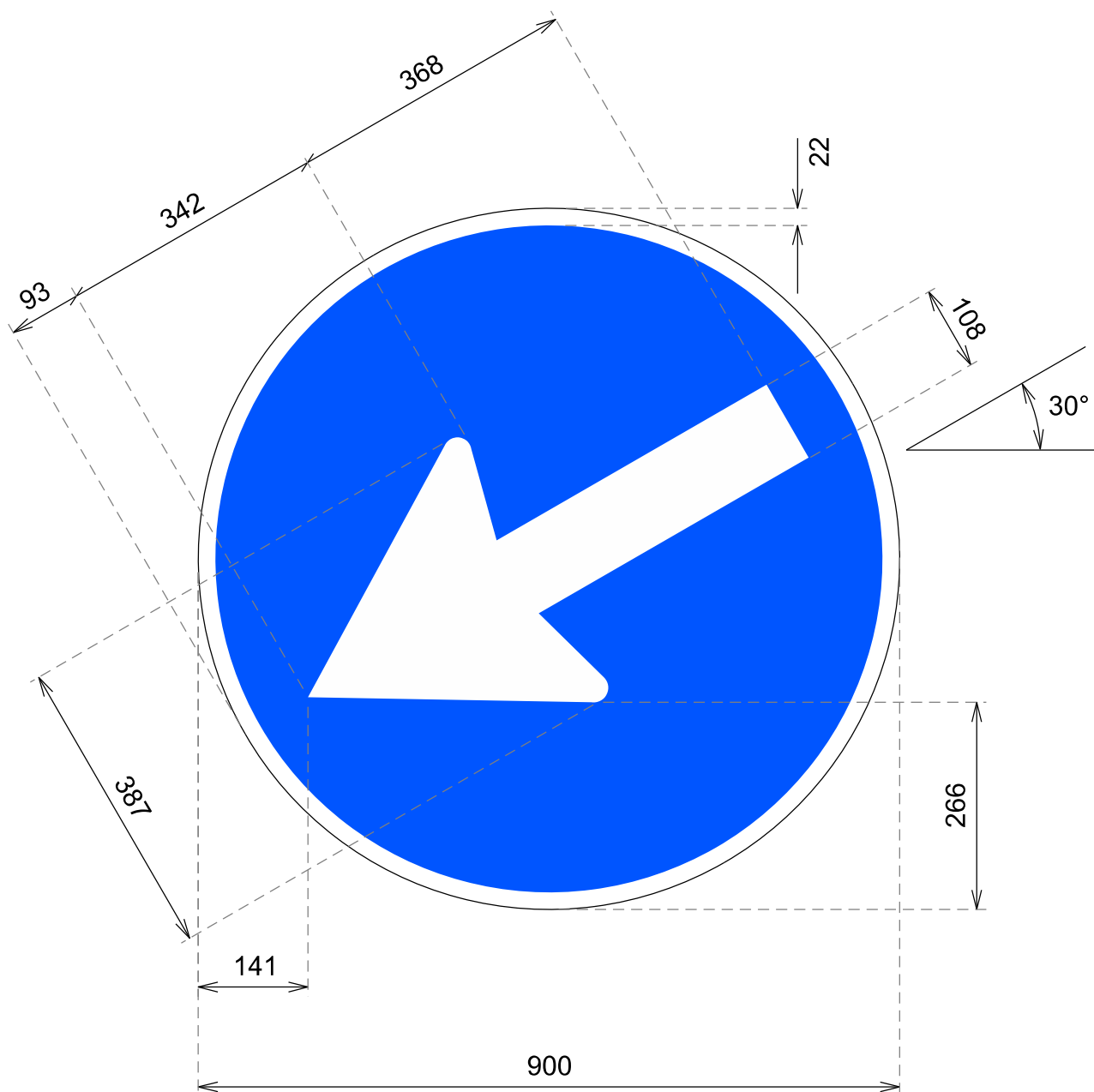

cotas en mm

Paso obligatorio

R-401b

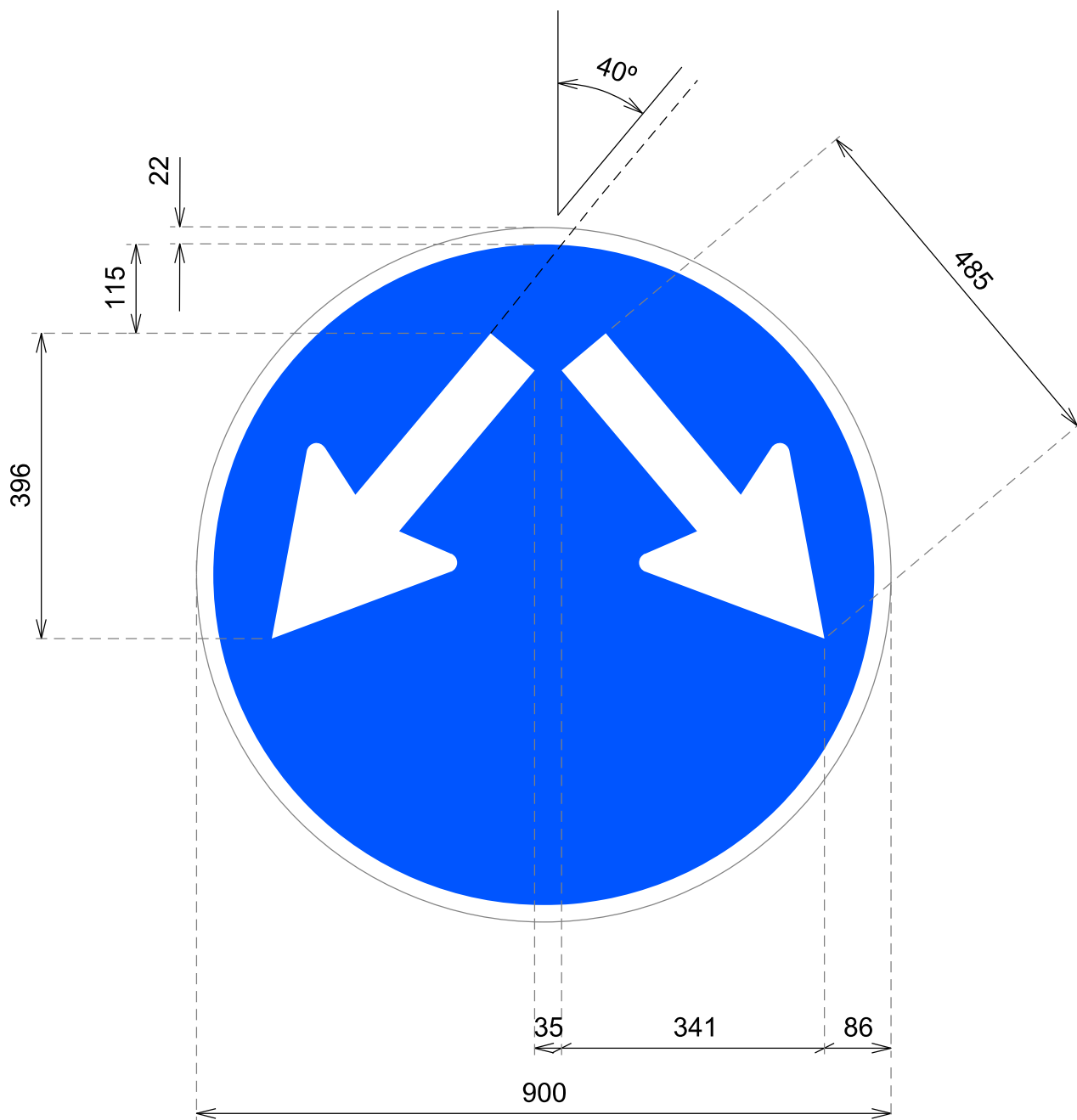

cotas en mm

Paso obligatorio

R-401c

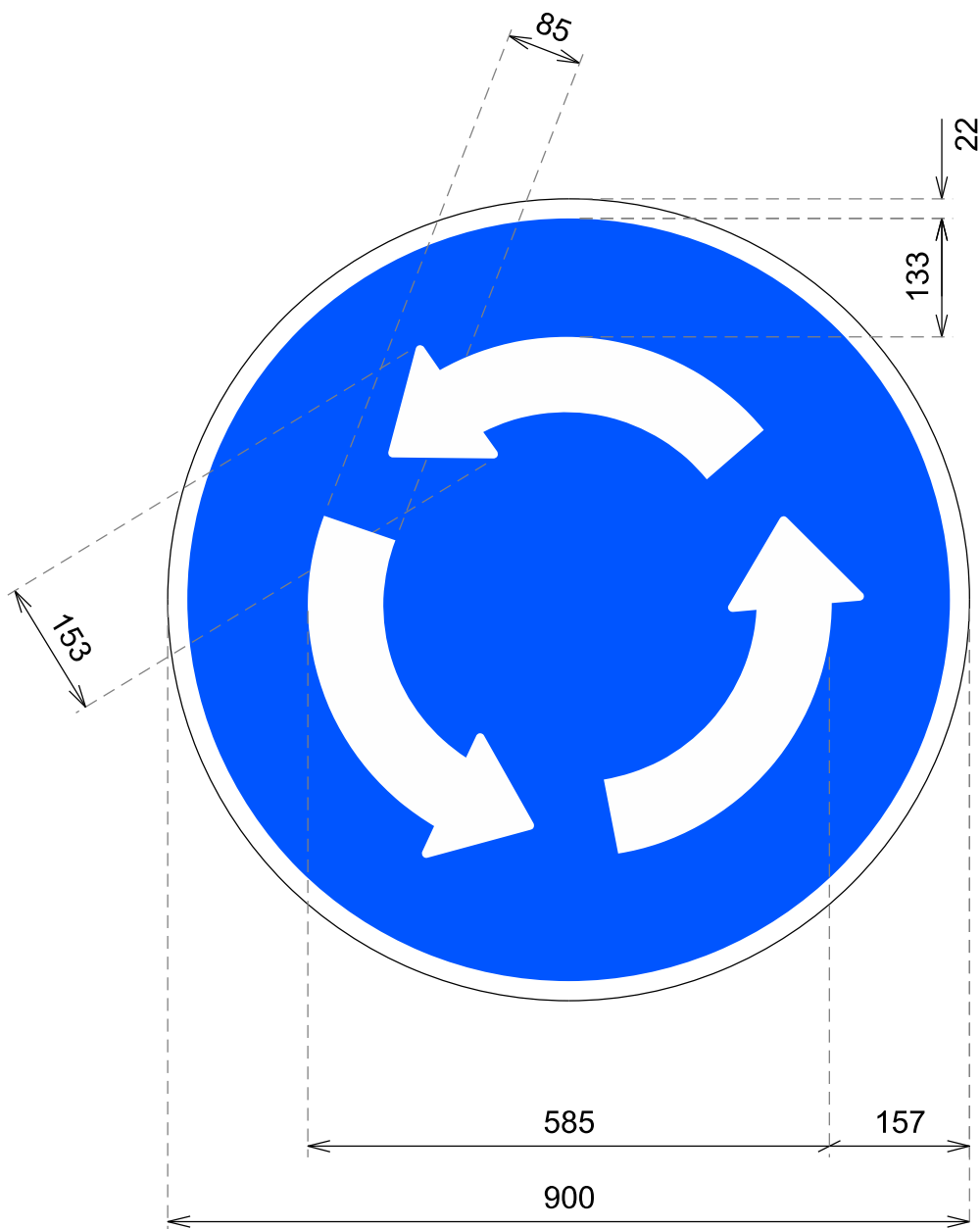

cotas en mm

Sentido obligatorio en glorieta

**R-402**

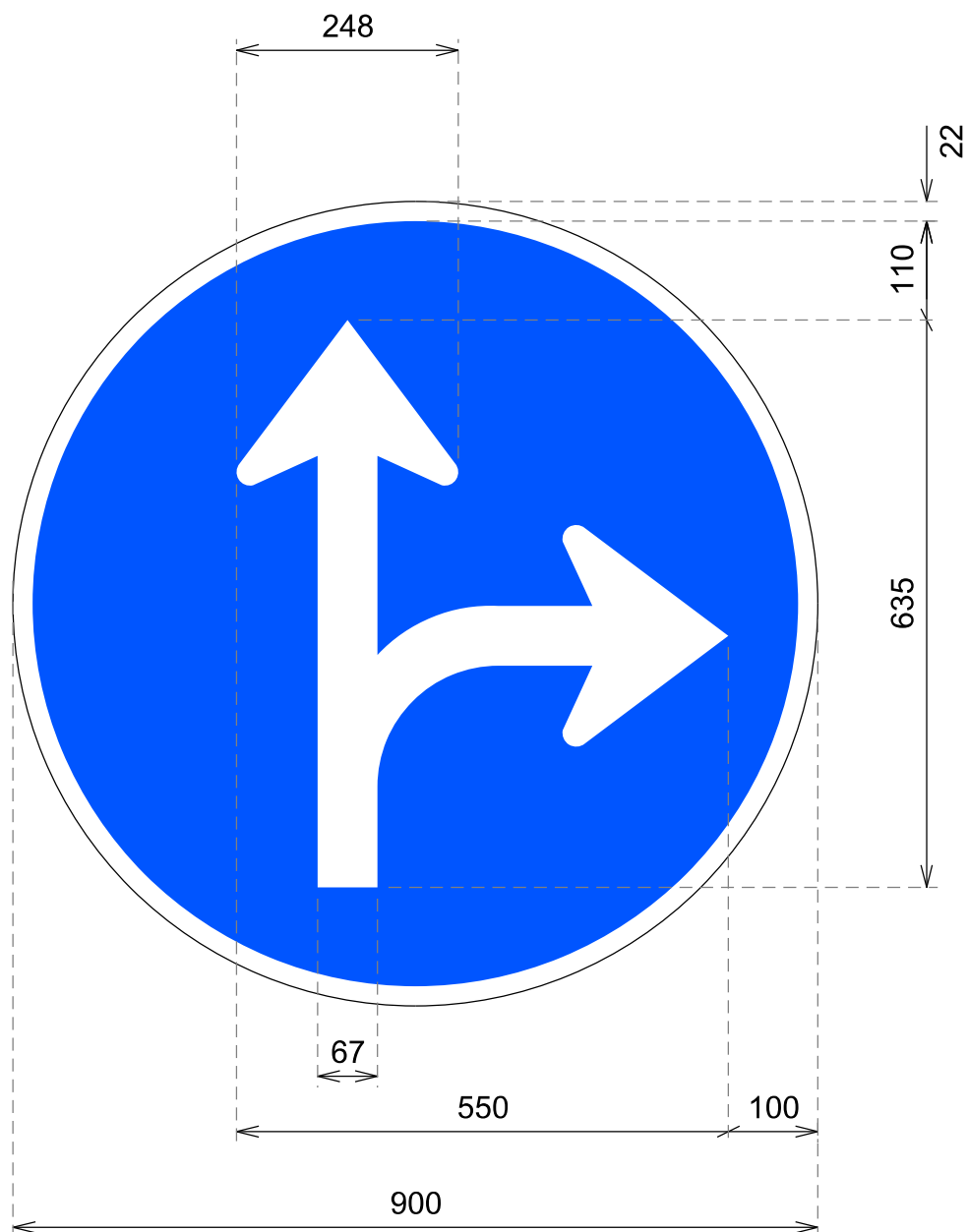

cotas en mm

Únicas direcciones y sentidos permitidos

R-403a

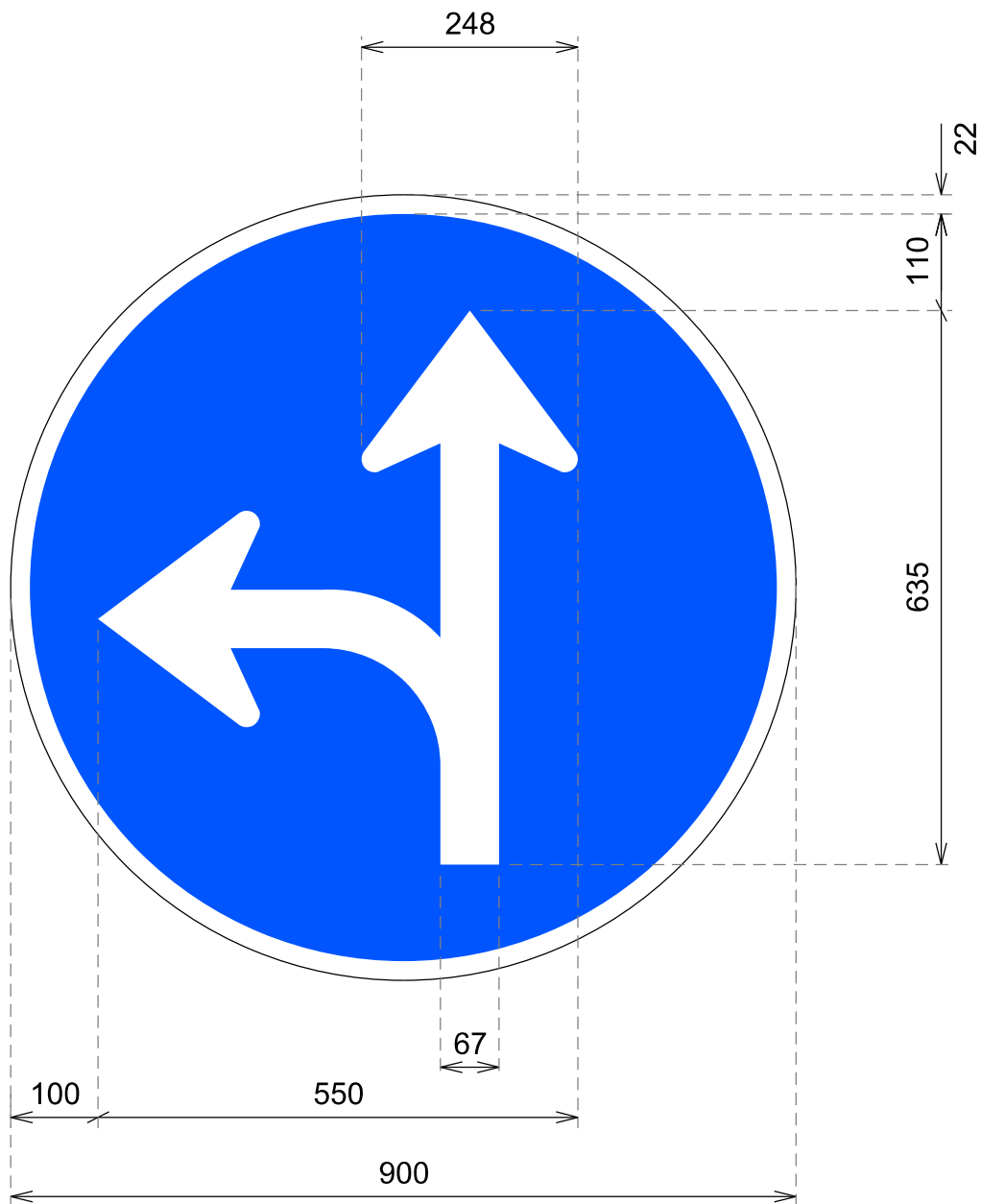

cotas en mm

Únicas direcciones y sentidos permitidos

R-403b

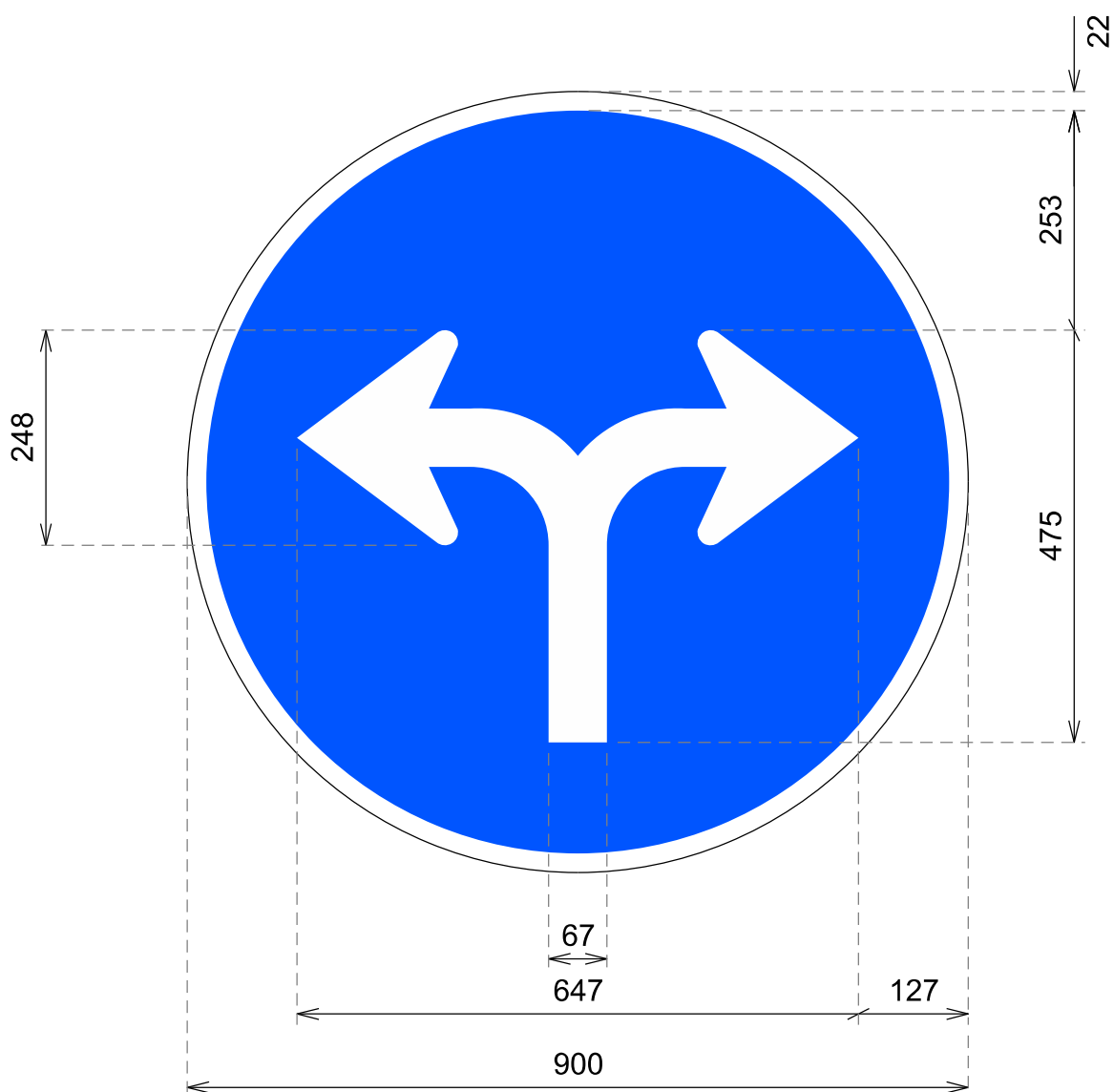

cotas en mm

Única dirección y sentidos permitidos

R-403c

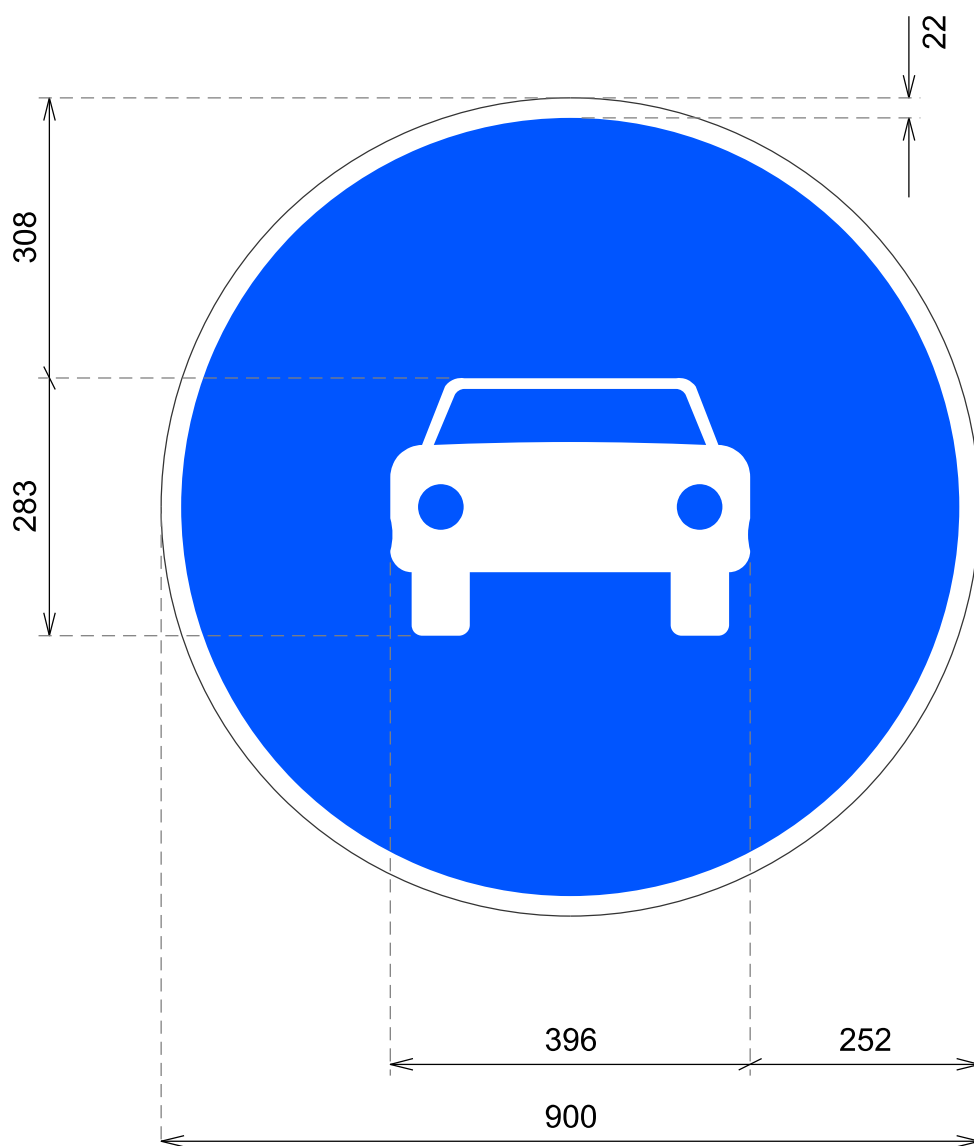

cotas en mm

Calzada obligatoria para automóviles, excepto motocicletas de dos ruedas

**R-404**



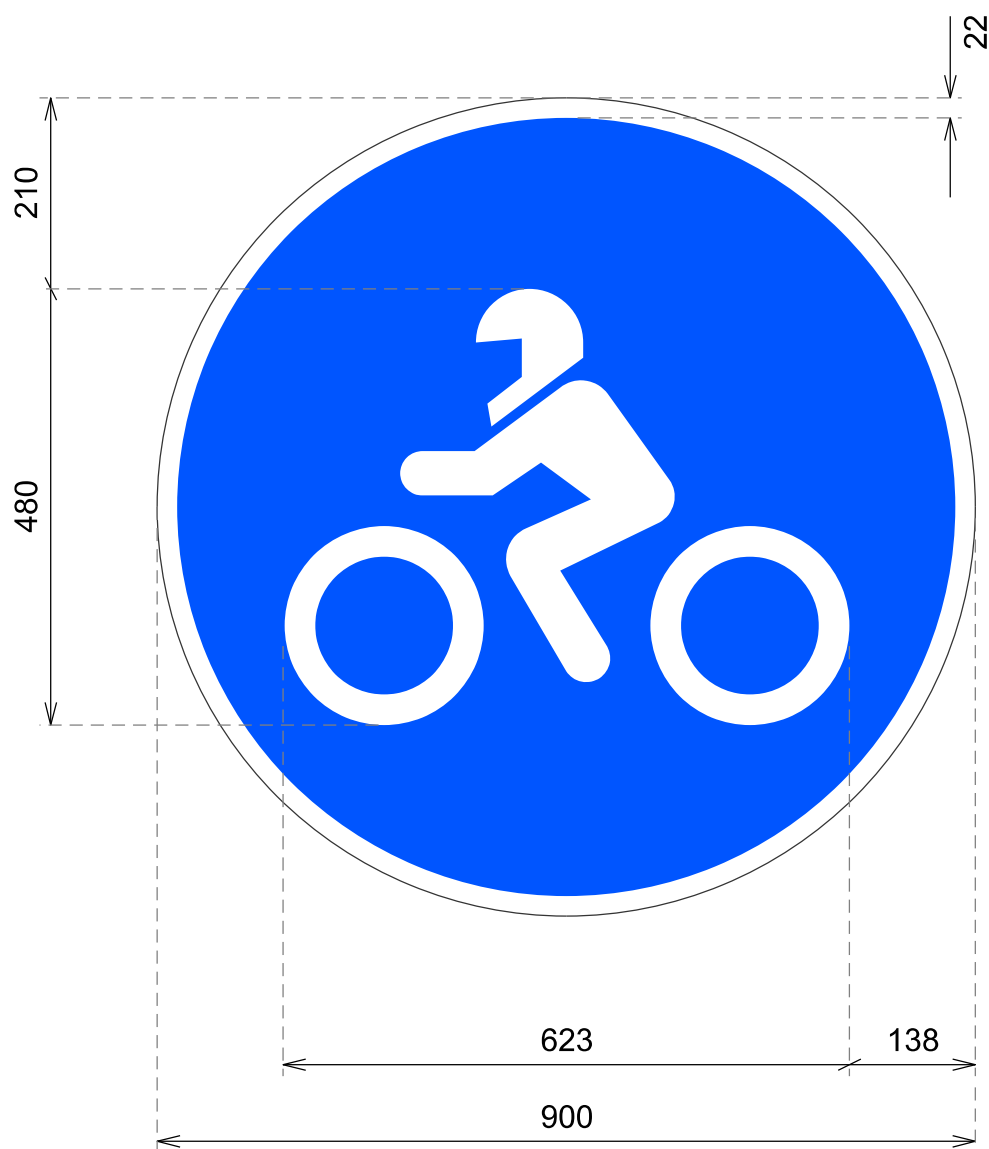

cotas en mm

Calzada obligatoria para motocicletas  
de dos ruedas

**R-405**

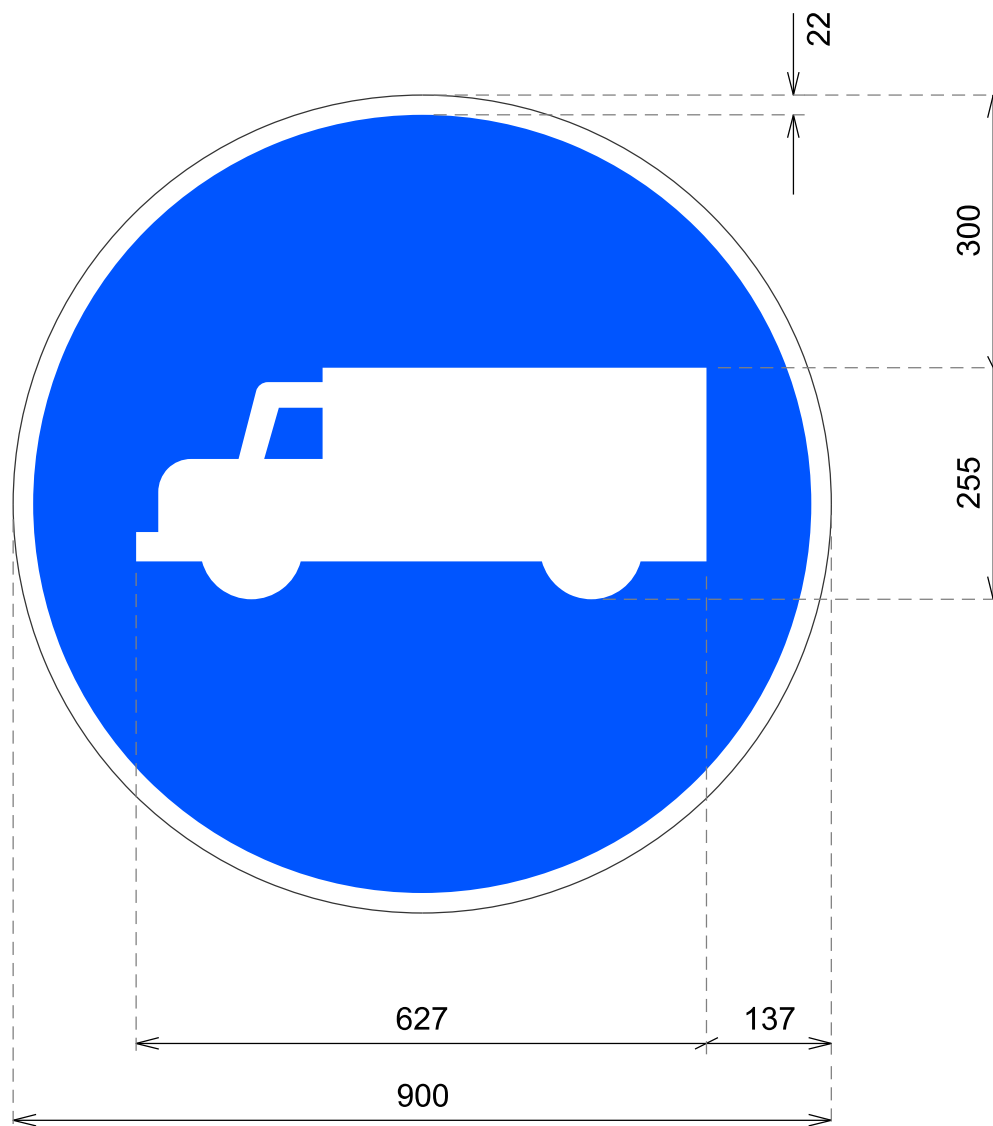

cotas en mm

Calzada obligatoria para camiones, tractocamiones  
y furgones o furgonetas

**R-406**

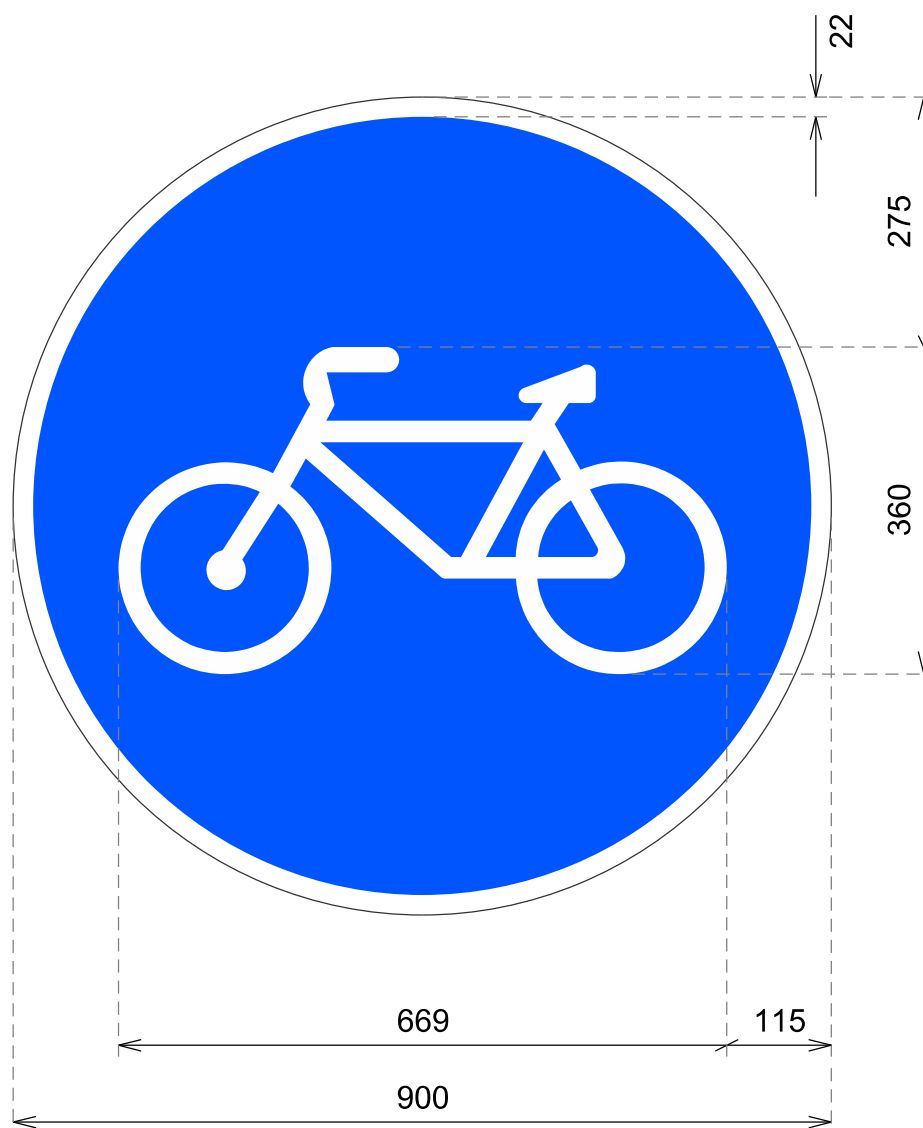

cotas en mm

Vía reservada y obligatoria para ciclos

**R-407a**

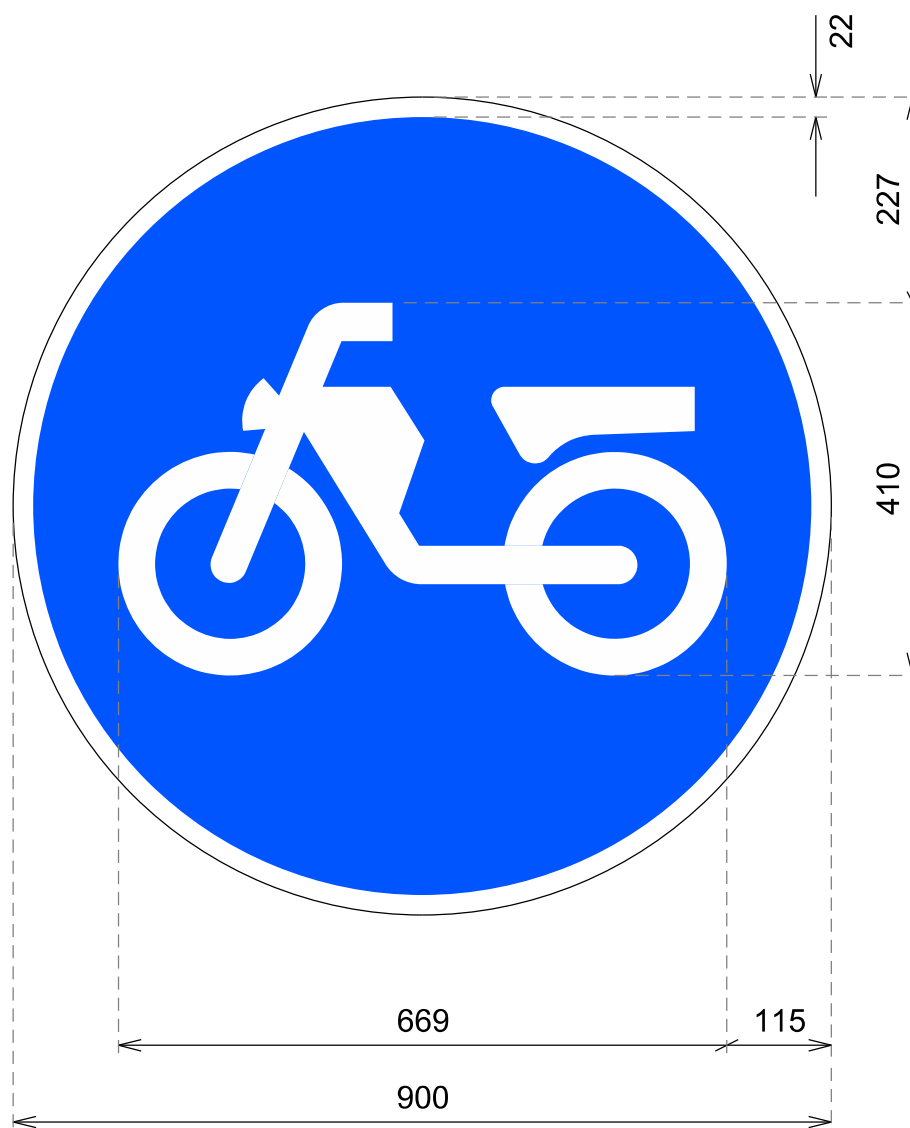

cotas en mm

Vía reservada y obligatoria para ciclomotores

**R-407b**

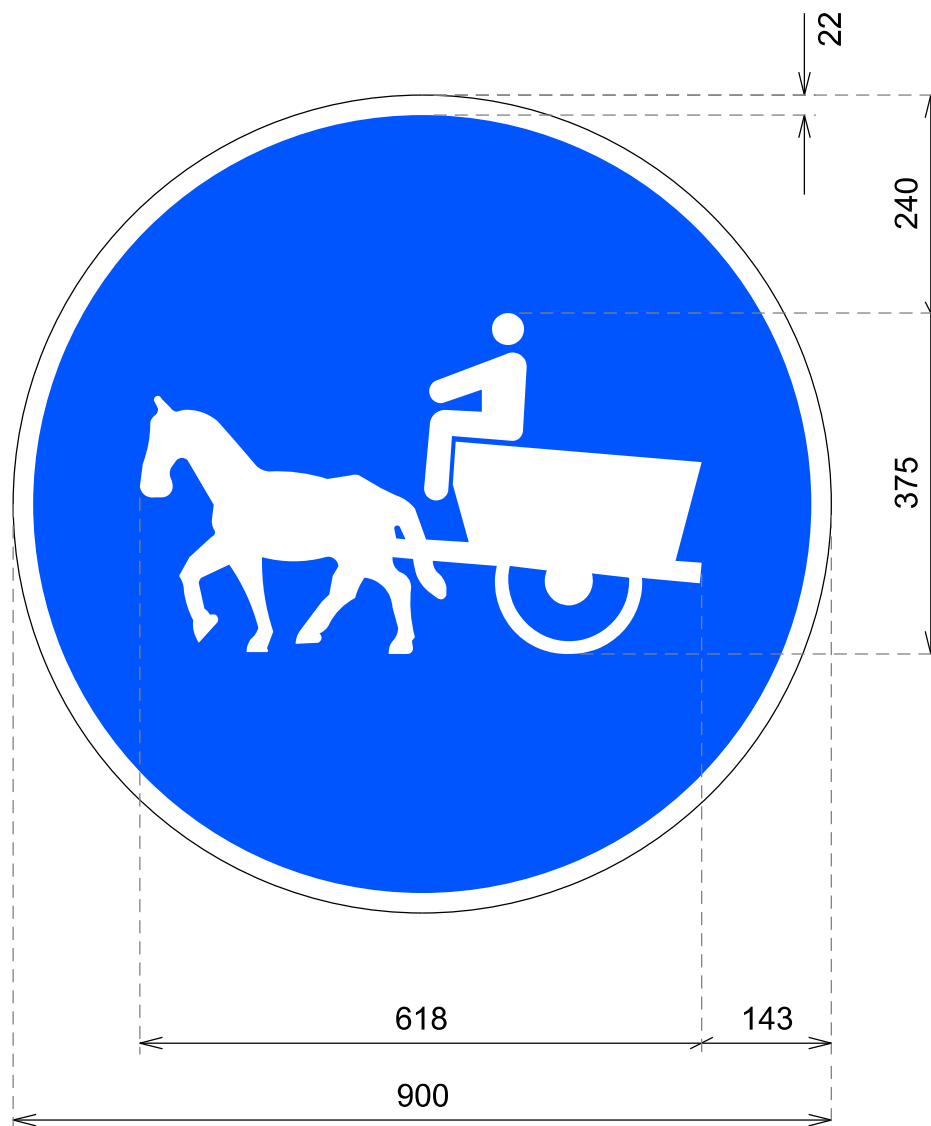

cotas en mm

Camino obligatorio para vehículos de tracción animal

**R-408**

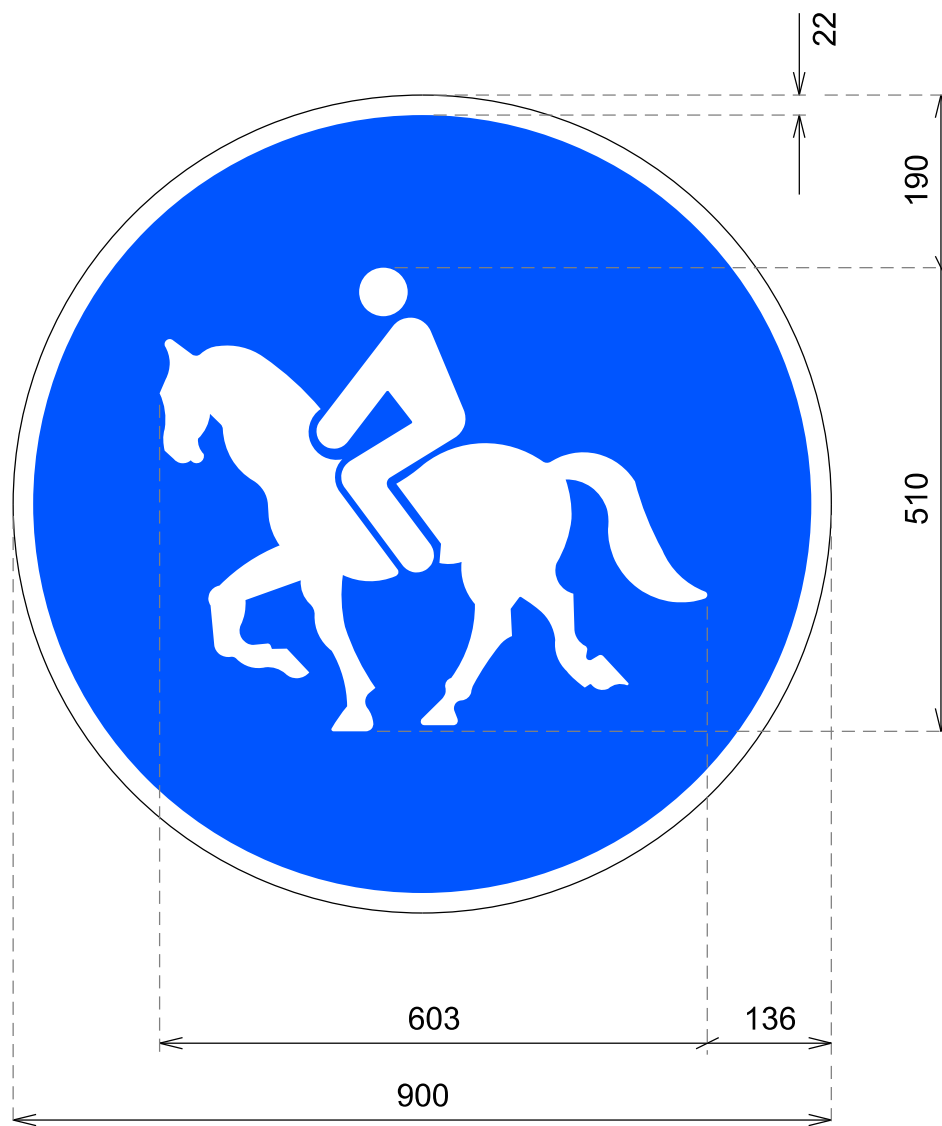

cotas en mm

Camino reservado y obligatorio para animales de montura

**R-409**

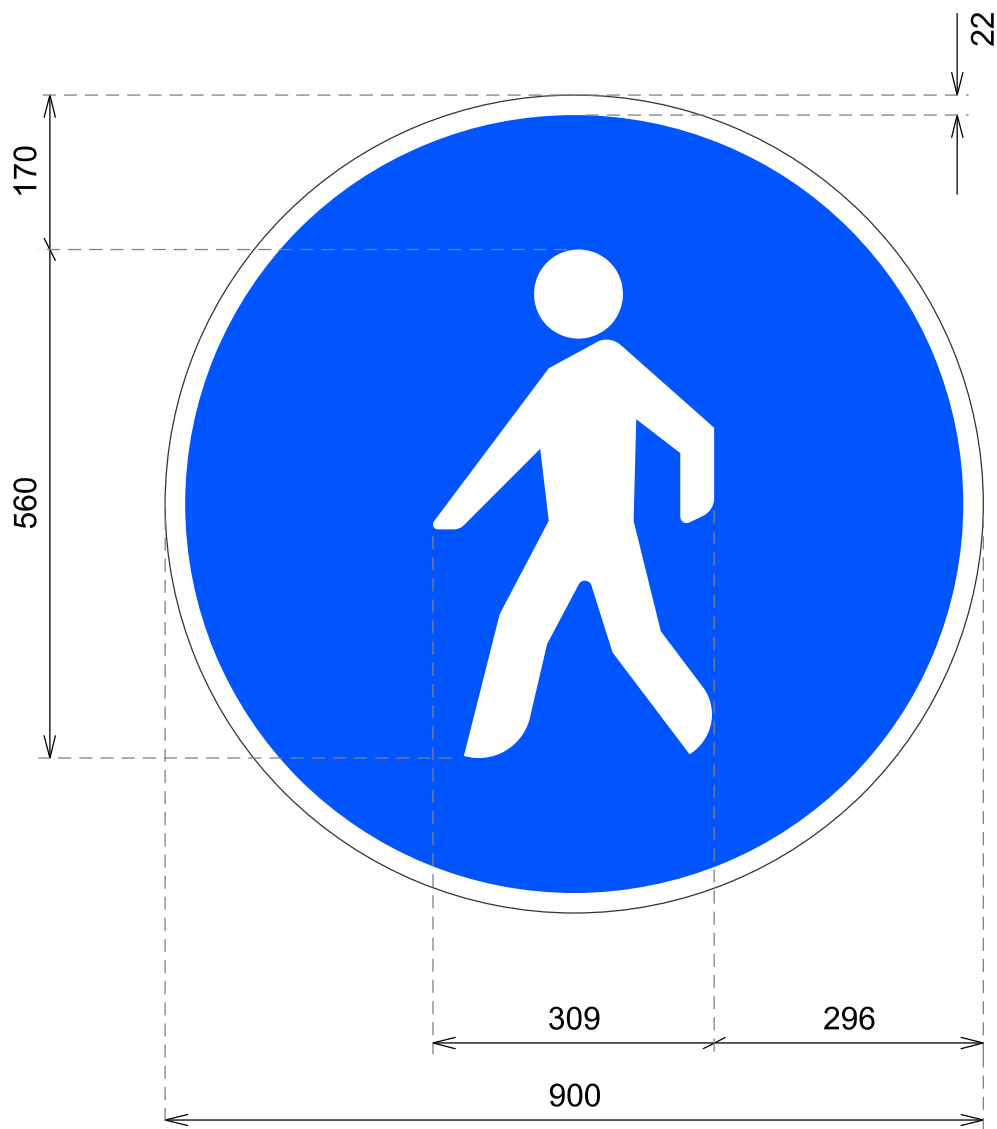

cotas en mm

Camino reservado y obligatorio para peatones

**R-410**

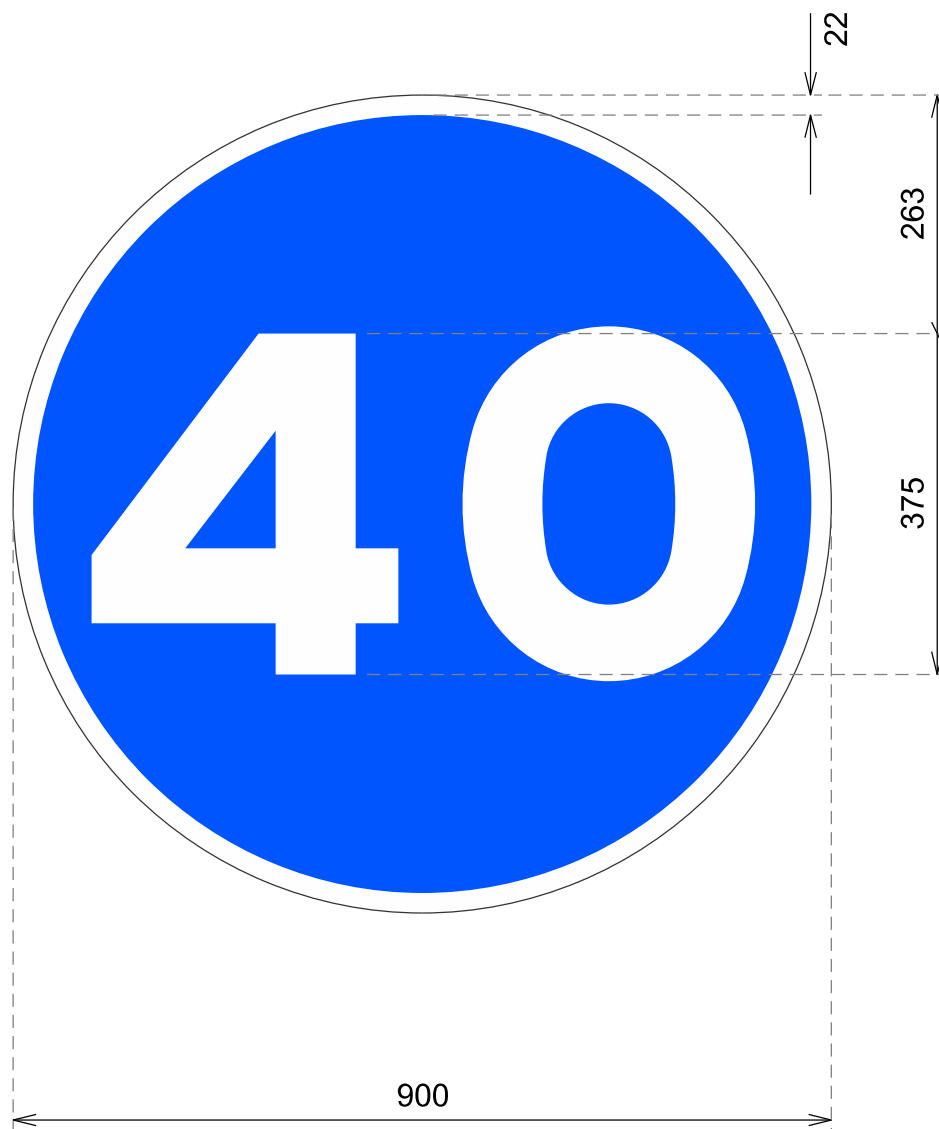

cotas en mm

Velocidad mínima

**R-411**



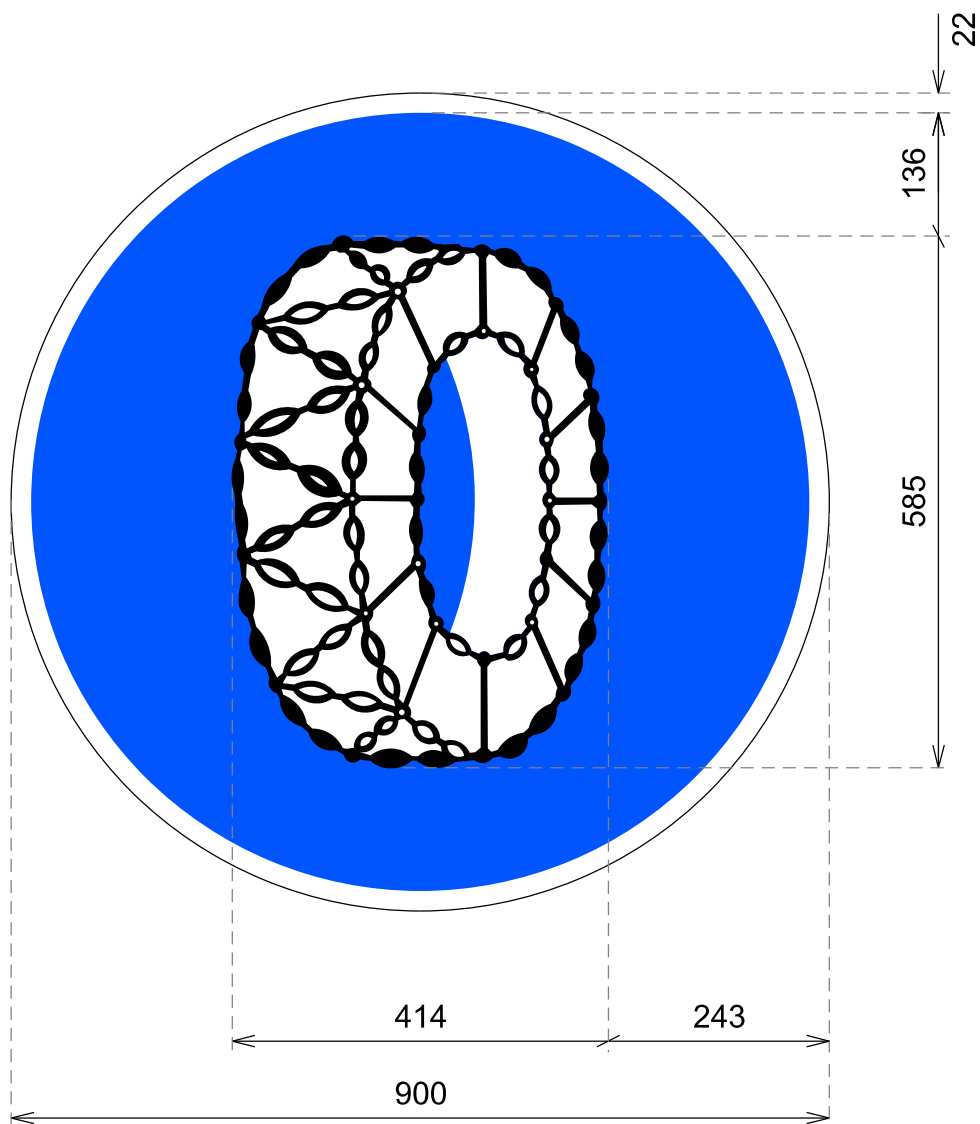

cotas en mm

Cadenas para nieve

**R-412**

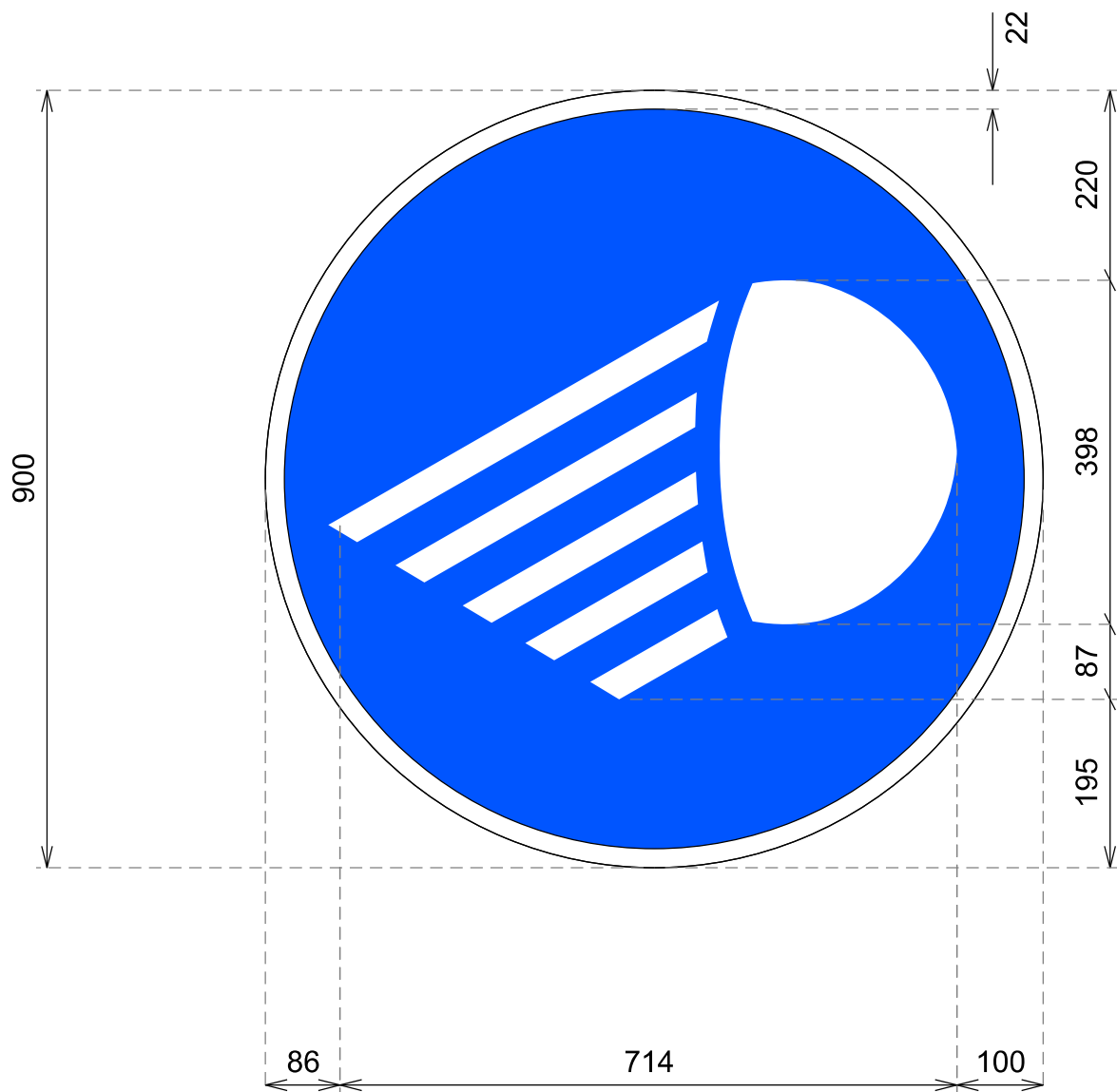

cotas en mm

Alumbrado de corto alcance

**R-413**

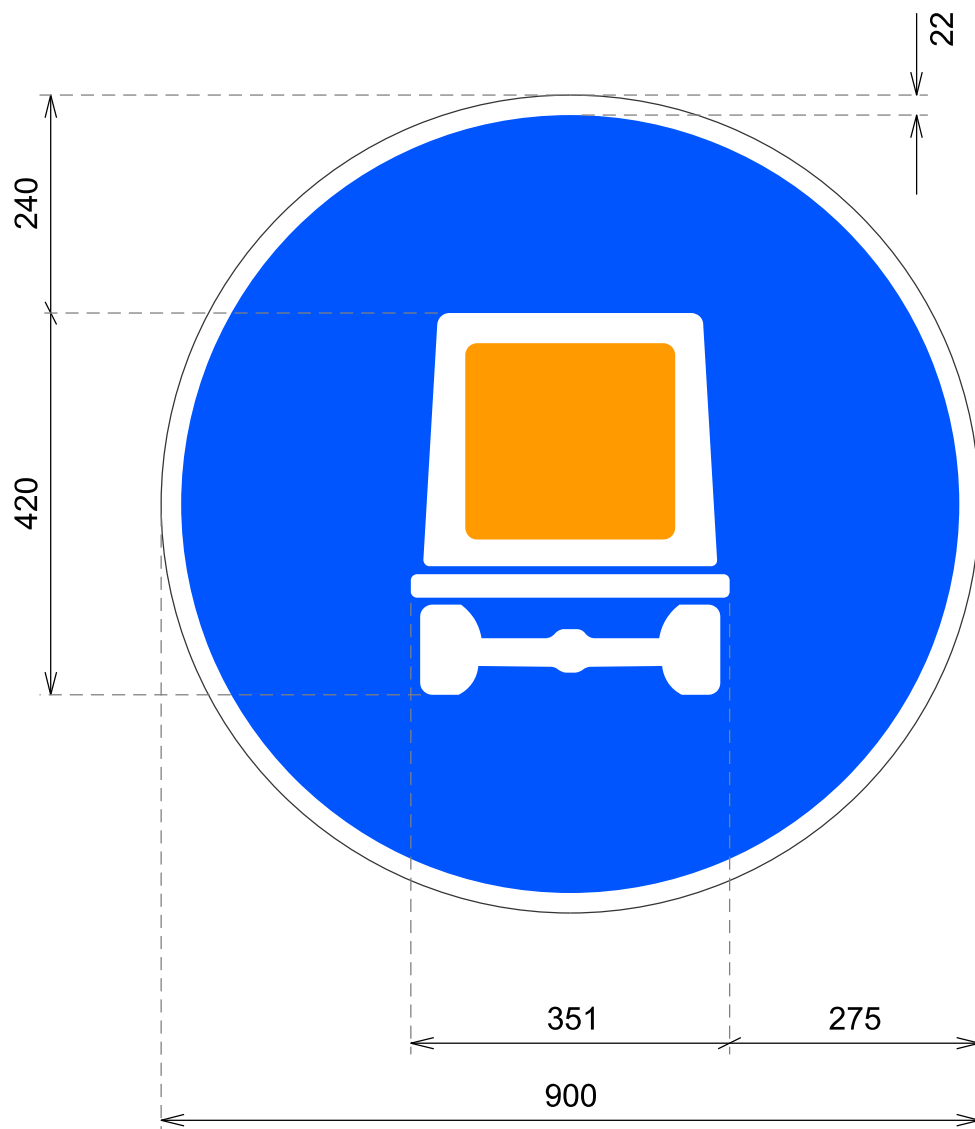

cotas en mm

Calzada obligatoria para vehículos que transporten mercancías peligrosas

**R-414**

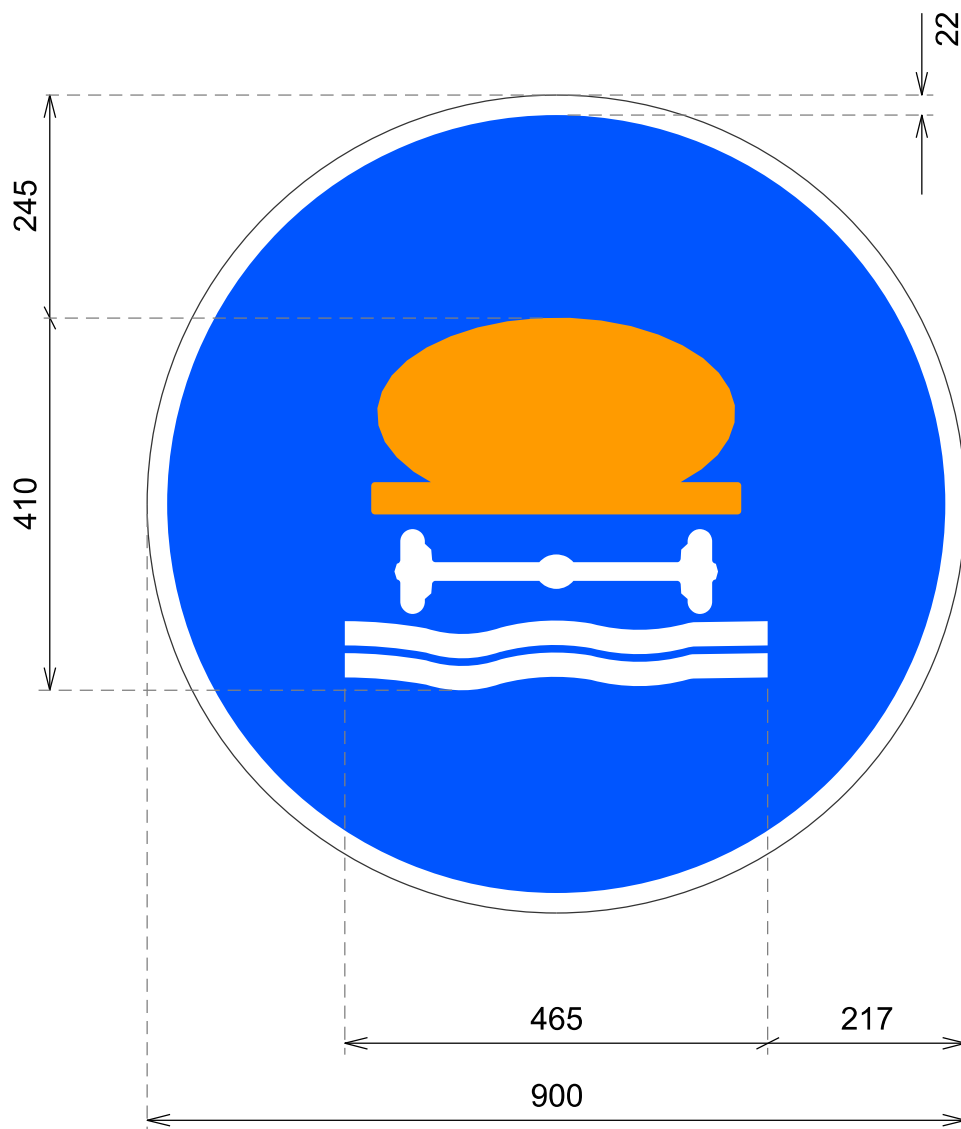

cotas en mm

Calzada obligatoria para vehículos que transporten  
productos contaminantes del agua

**R-415**

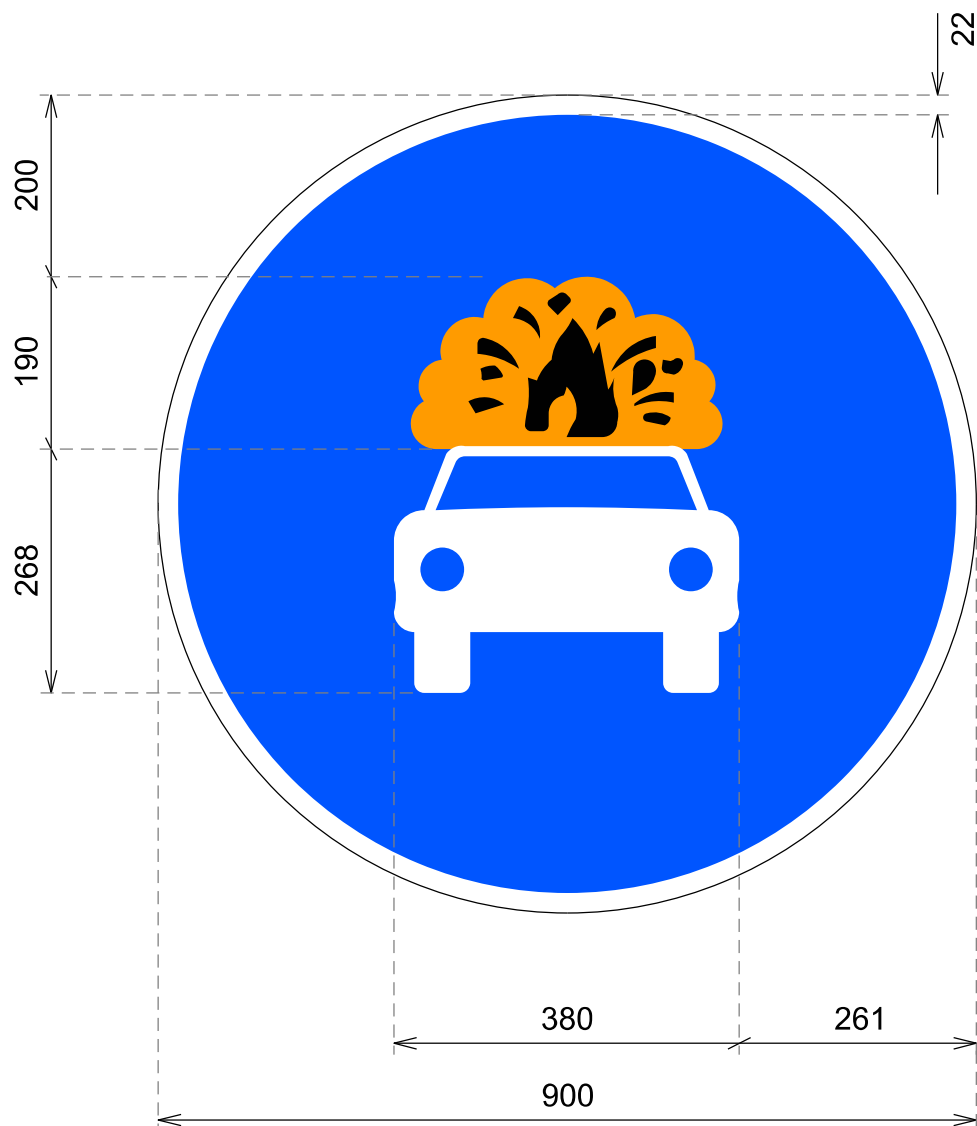

cotas en mm

Calzada obligatoria para vehículos que transporten mercancías explosivas o inflamables

**R-416**

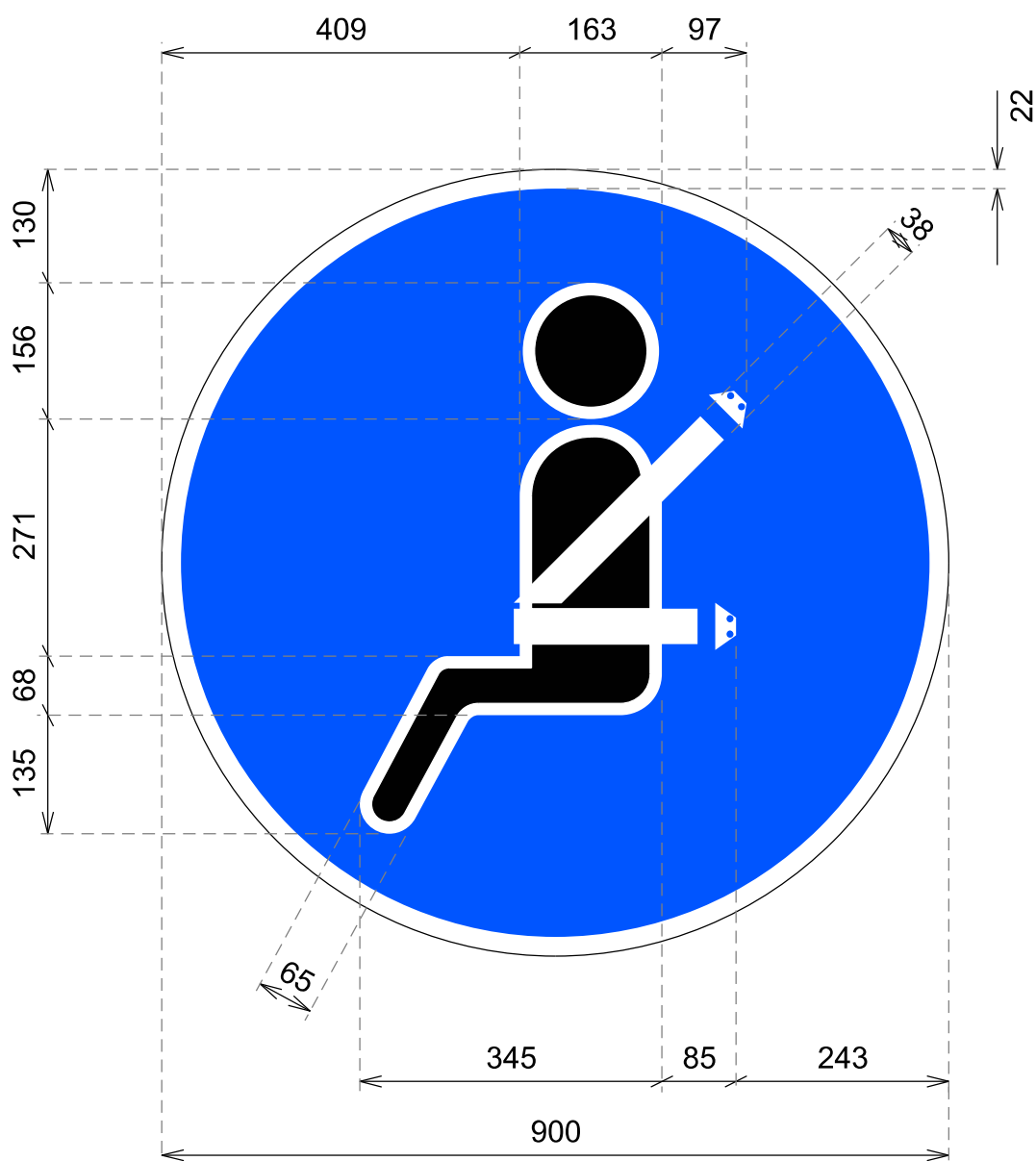

cotas en mm

Uso obligatorio del cinturón de seguridad

**R-417**

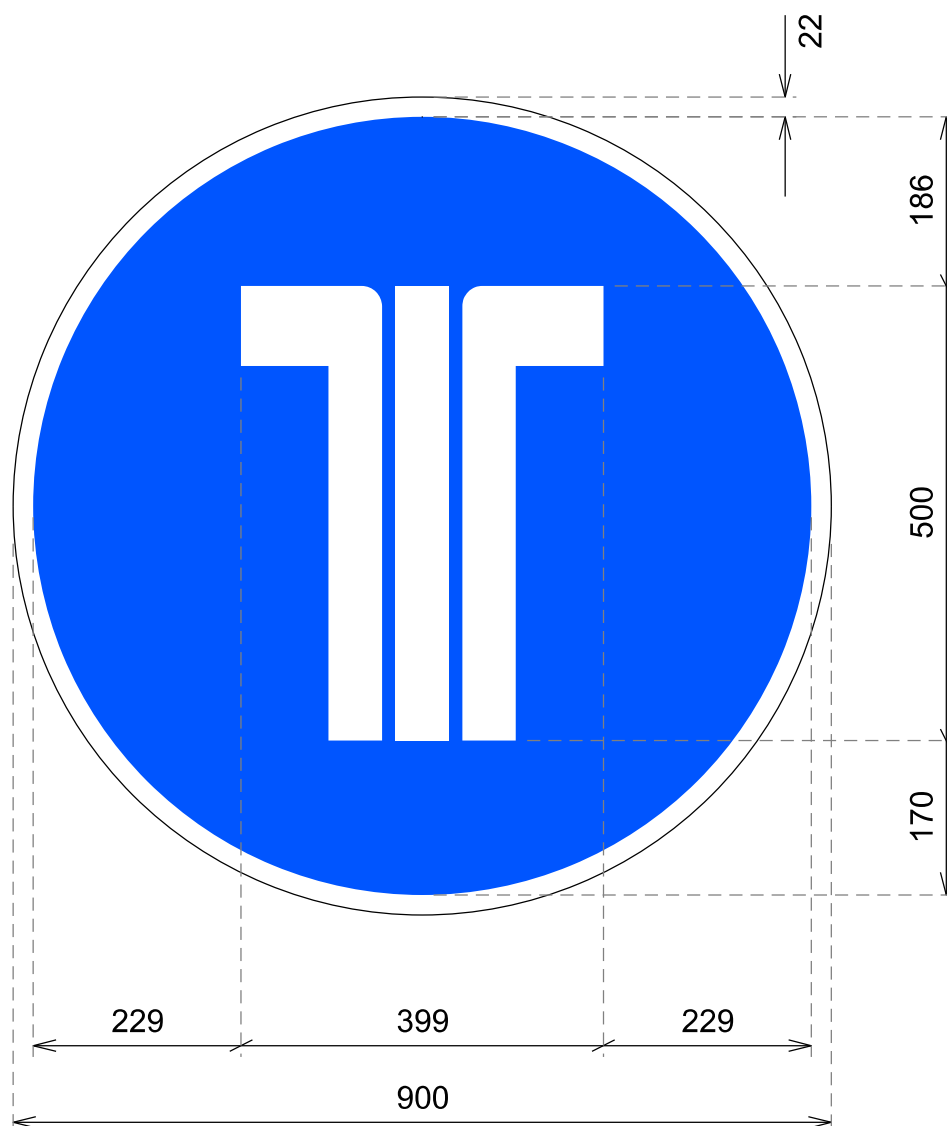

cotas en mm

Vía exclusiva para vehículos dotados de equipo  
de telepeaje operativo. Telepeaje obligatorio

**R-418**

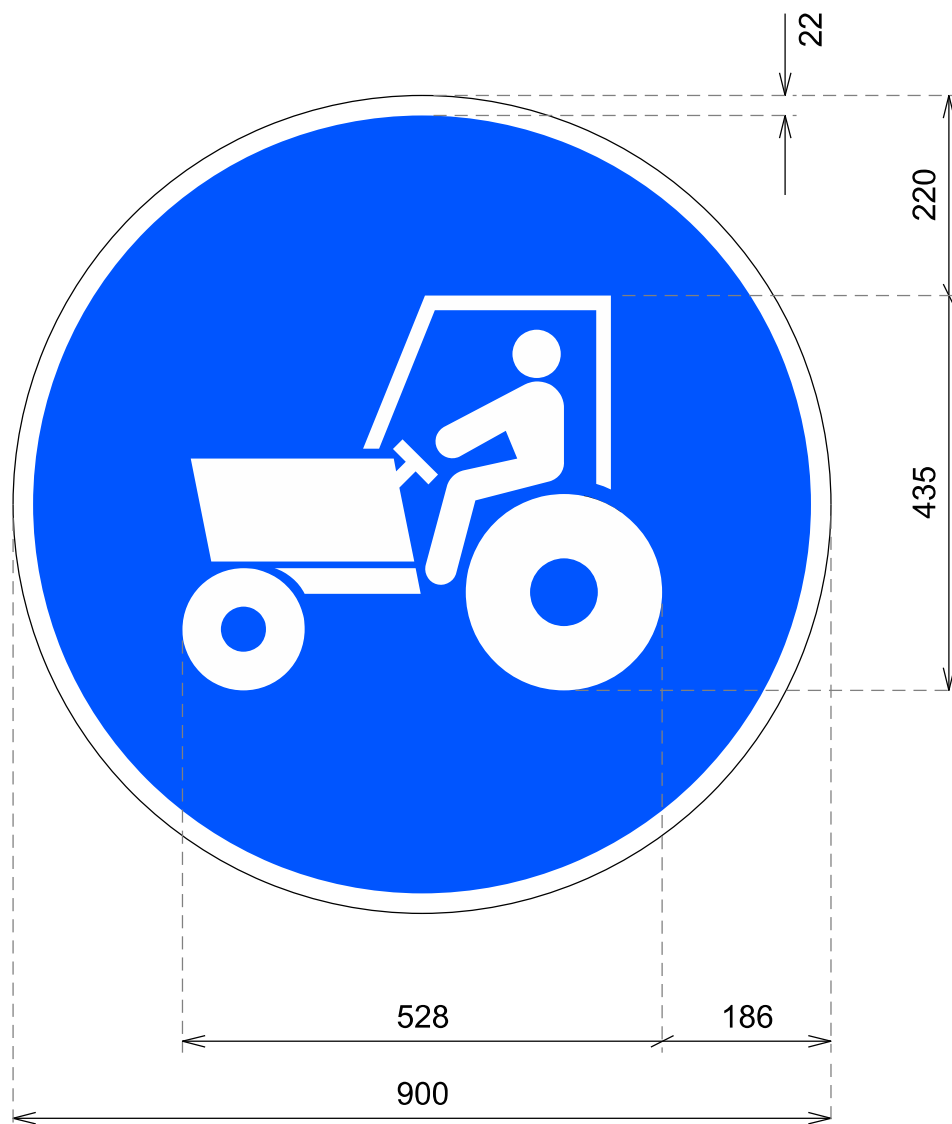

cotas en mm

Camino obligatorio para tractores

**R-419**



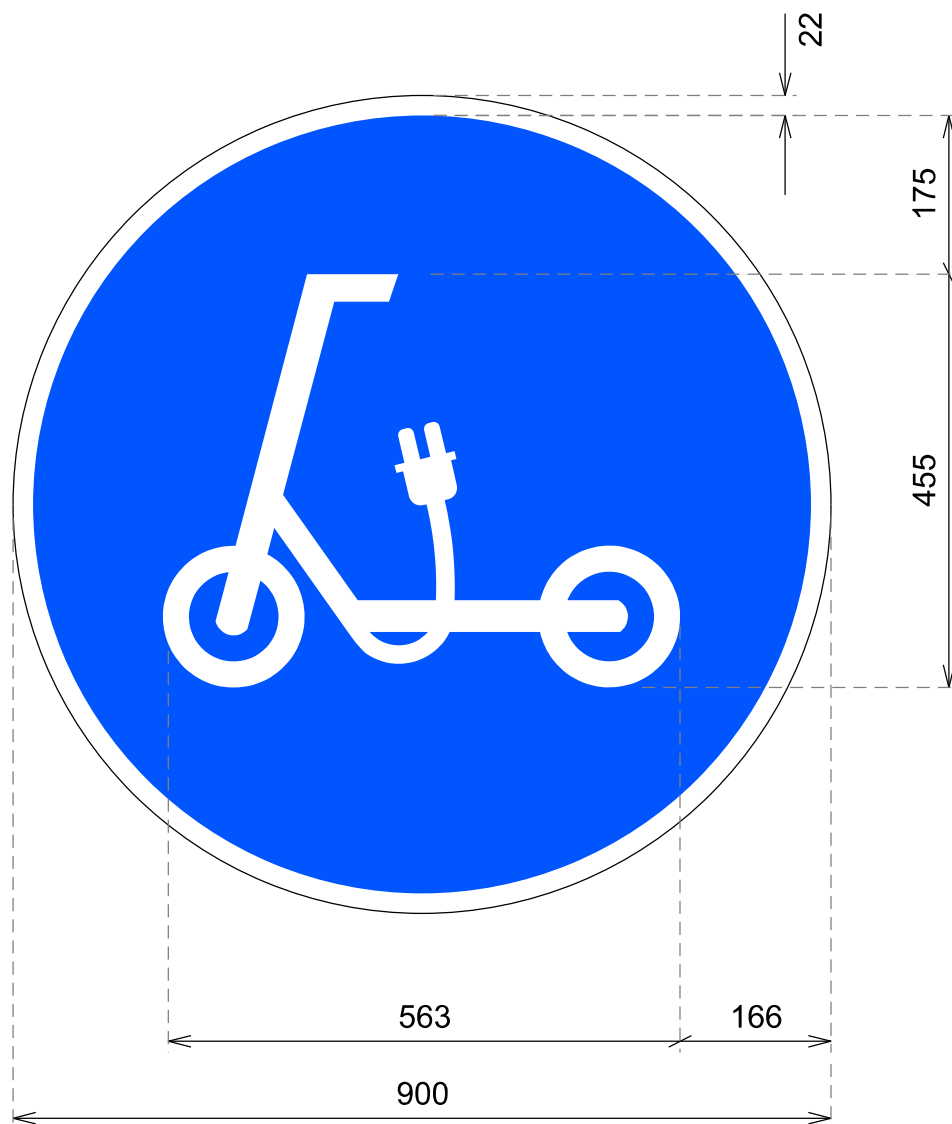

cotas en mm

Vía reservada y obligatoria para  
vehículos de movilidad personal

**R-420**

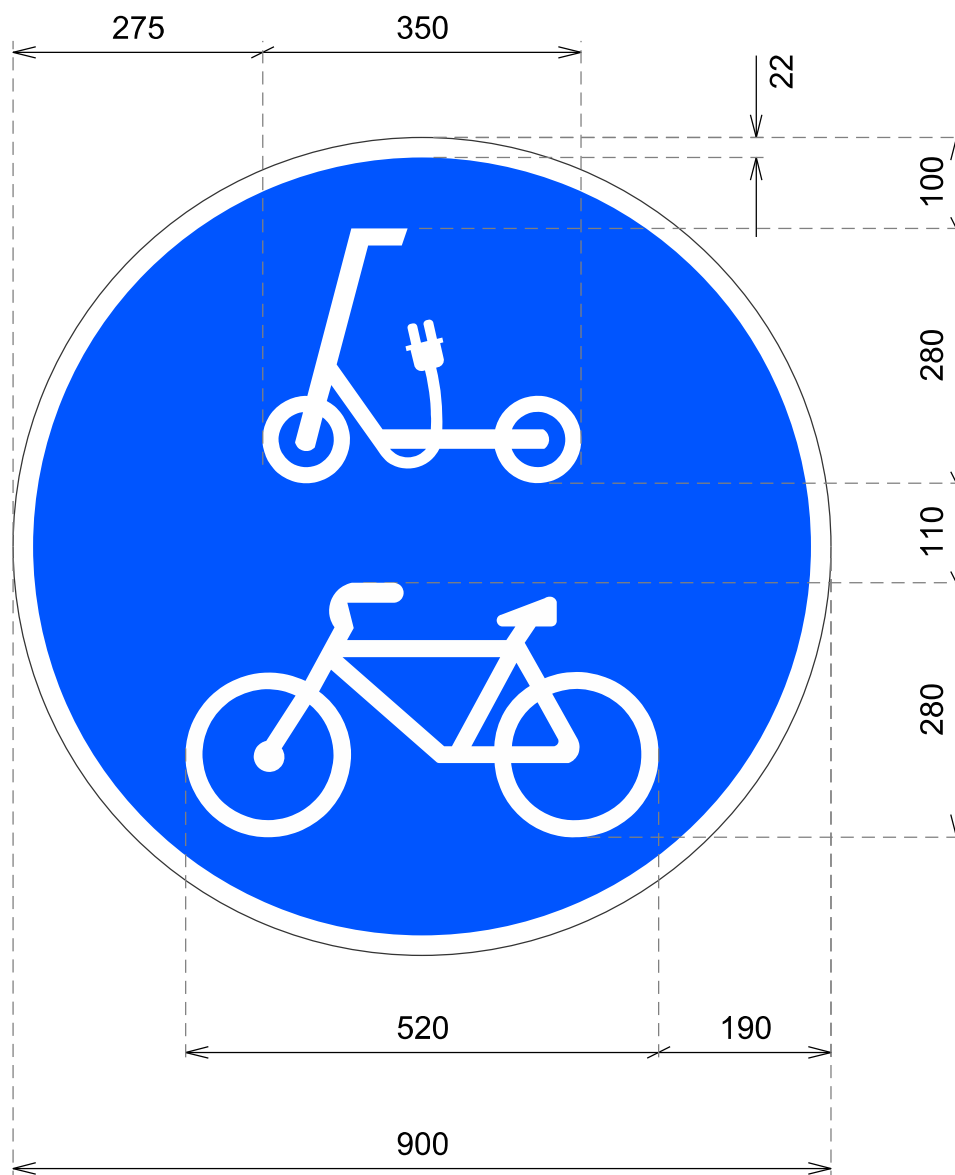

cotas en mm

Vía reservada y obligatoria para ciclos y para vehículos de movilidad personal

**R-421**

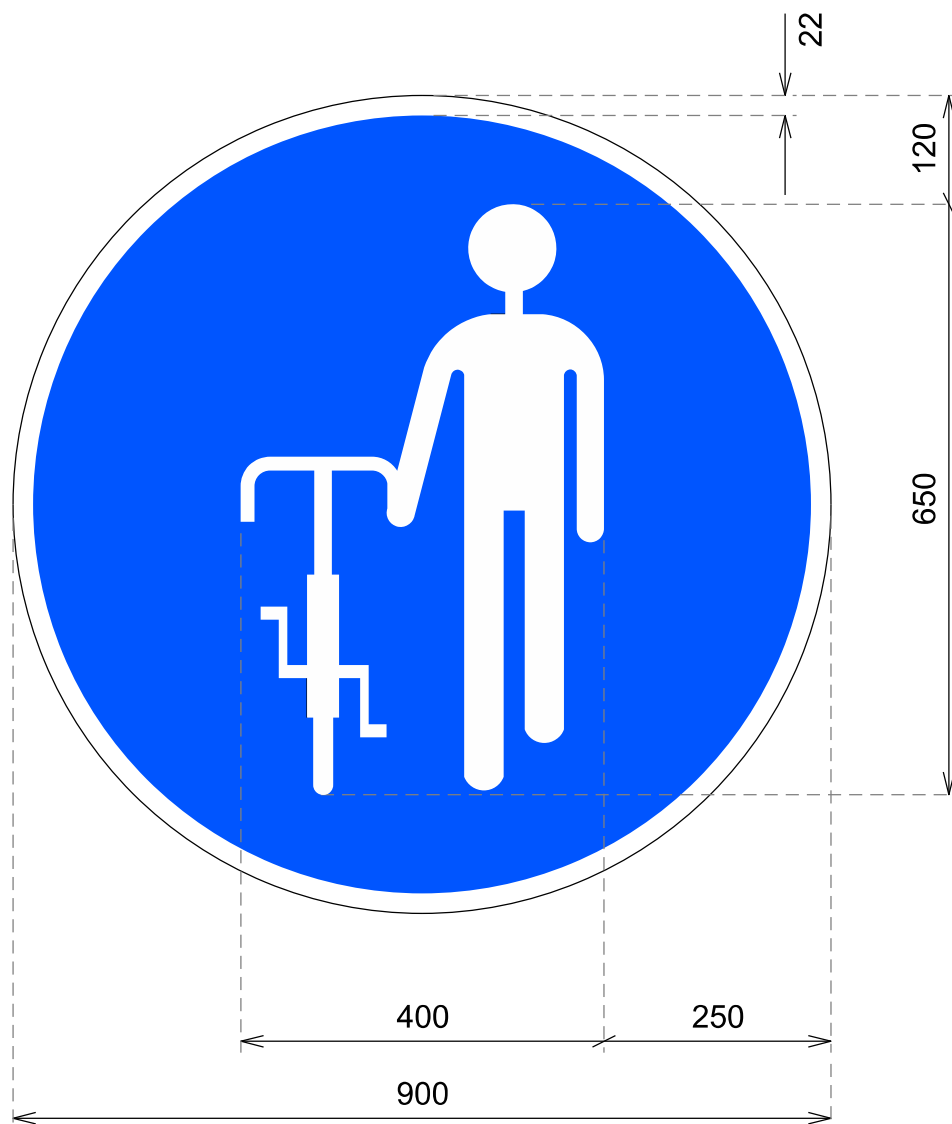

cotas en mm

Desmontar y continuar a pie

**R-422**

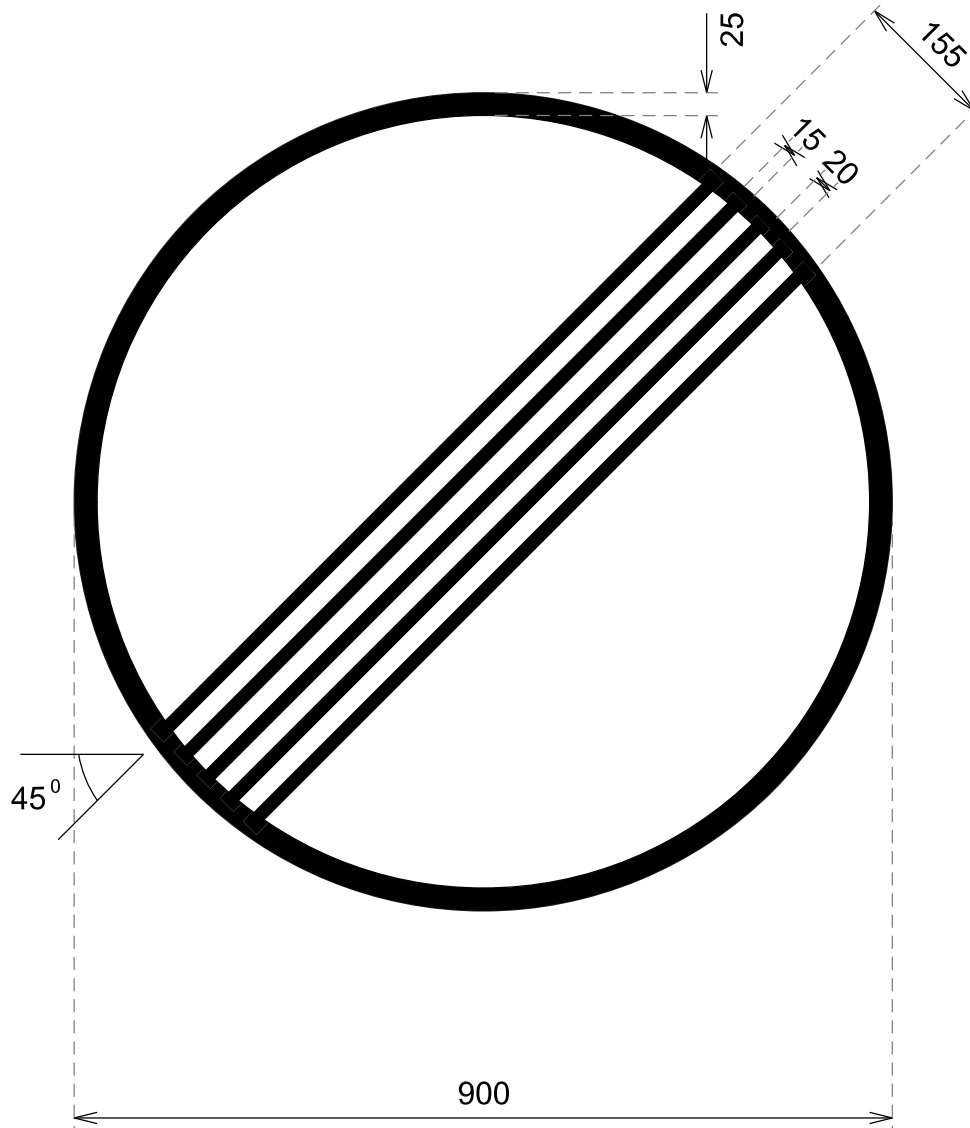

cotas en mm

Fin de prohibiciones

**R-500**



# SEÑALES DE REGLAMENTACIÓN

## FIN DE PROHIBICIÓN, RESTRICCIÓN U OBLIGACIÓN

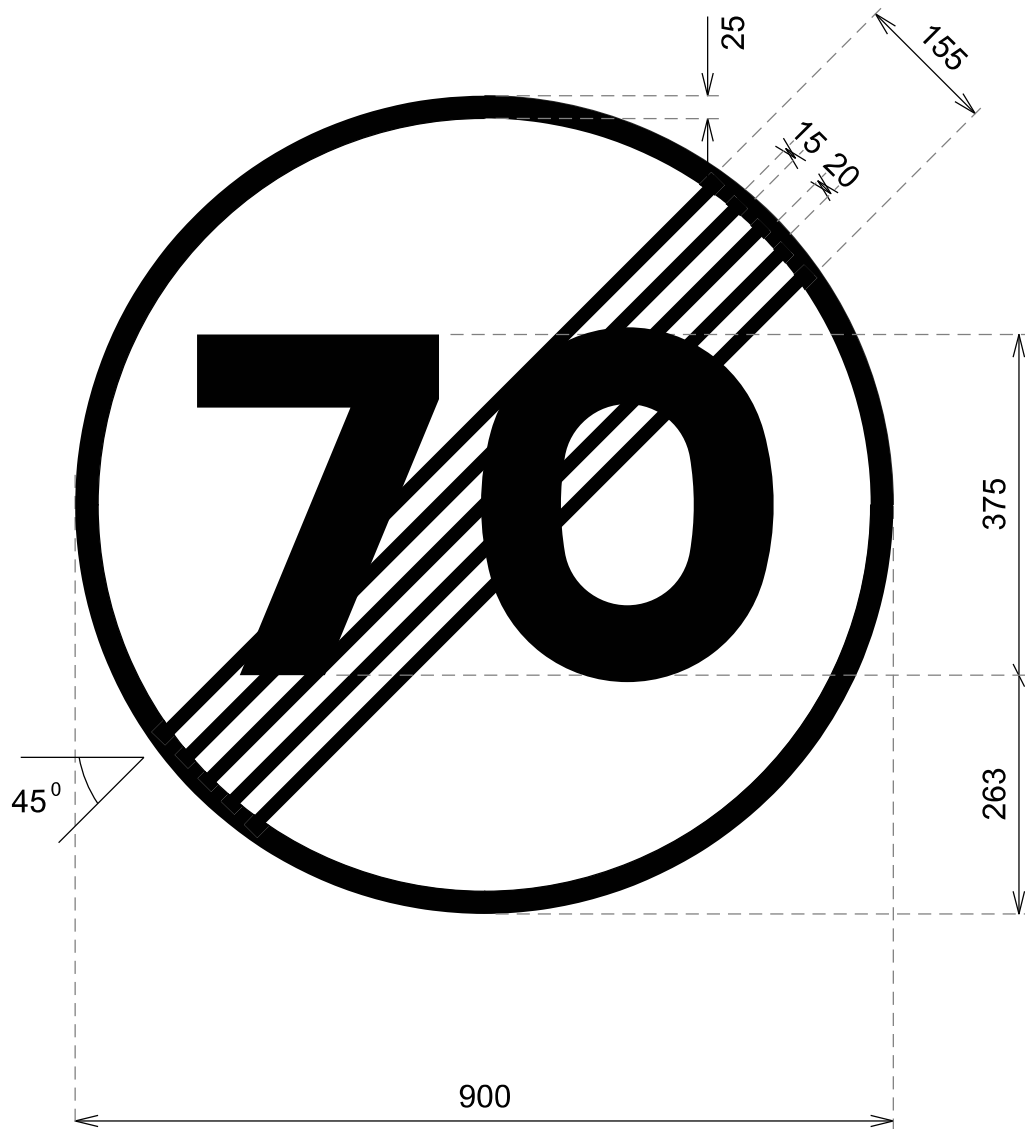

cotas en mm

Fin de la limitación de velocidad

**R-501**



# SEÑALES DE REGLAMENTACIÓN

## FIN DE PROHIBICIÓN, RESTRICCIÓN U OBLIGACIÓN

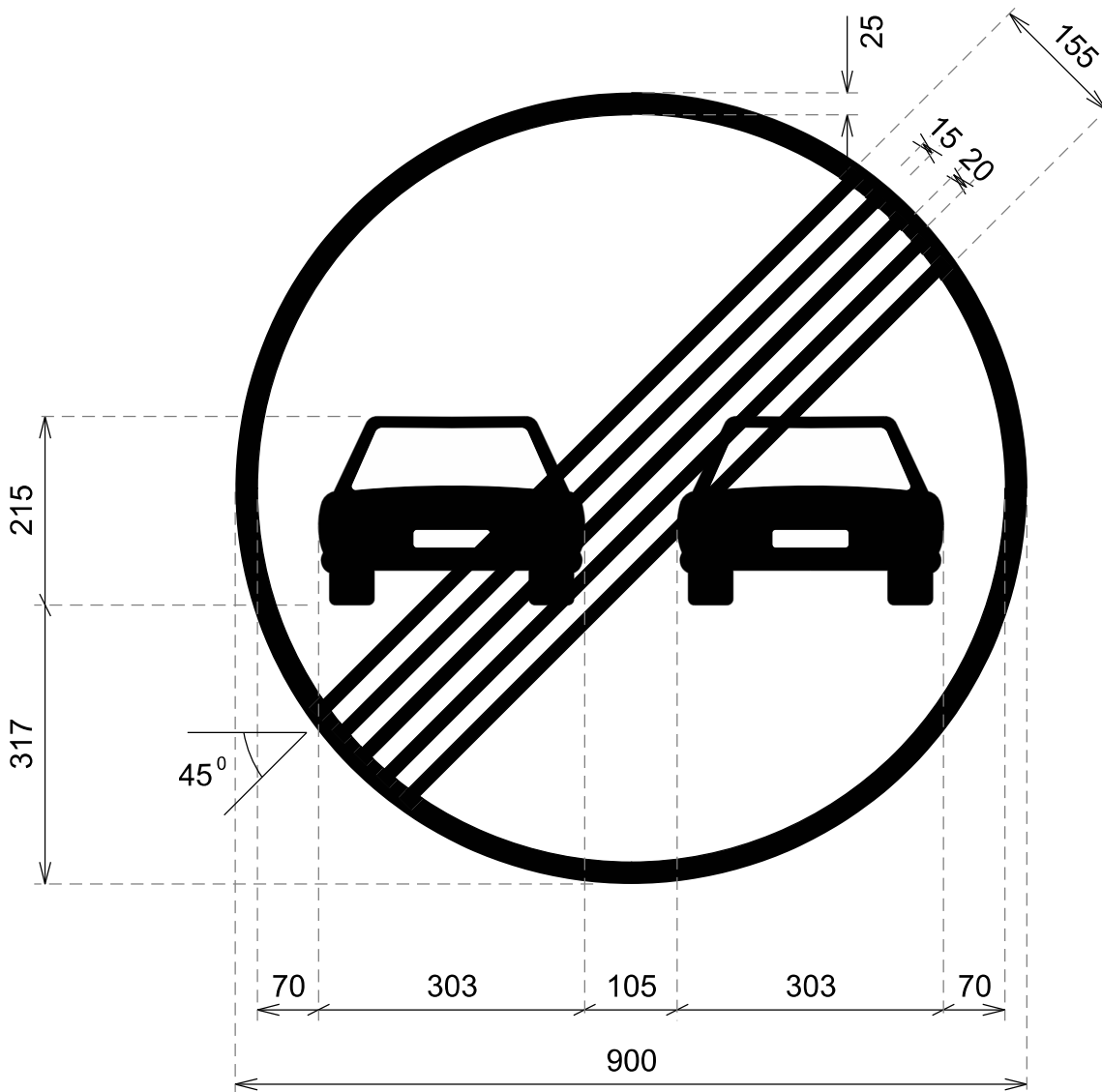

cotas en mm

Fin de la prohibición de adelantamiento

**R-502**



# SEÑALES DE REGLAMENTACIÓN

## FIN DE PROHIBICIÓN, RESTRICCIÓN U OBLIGACIÓN

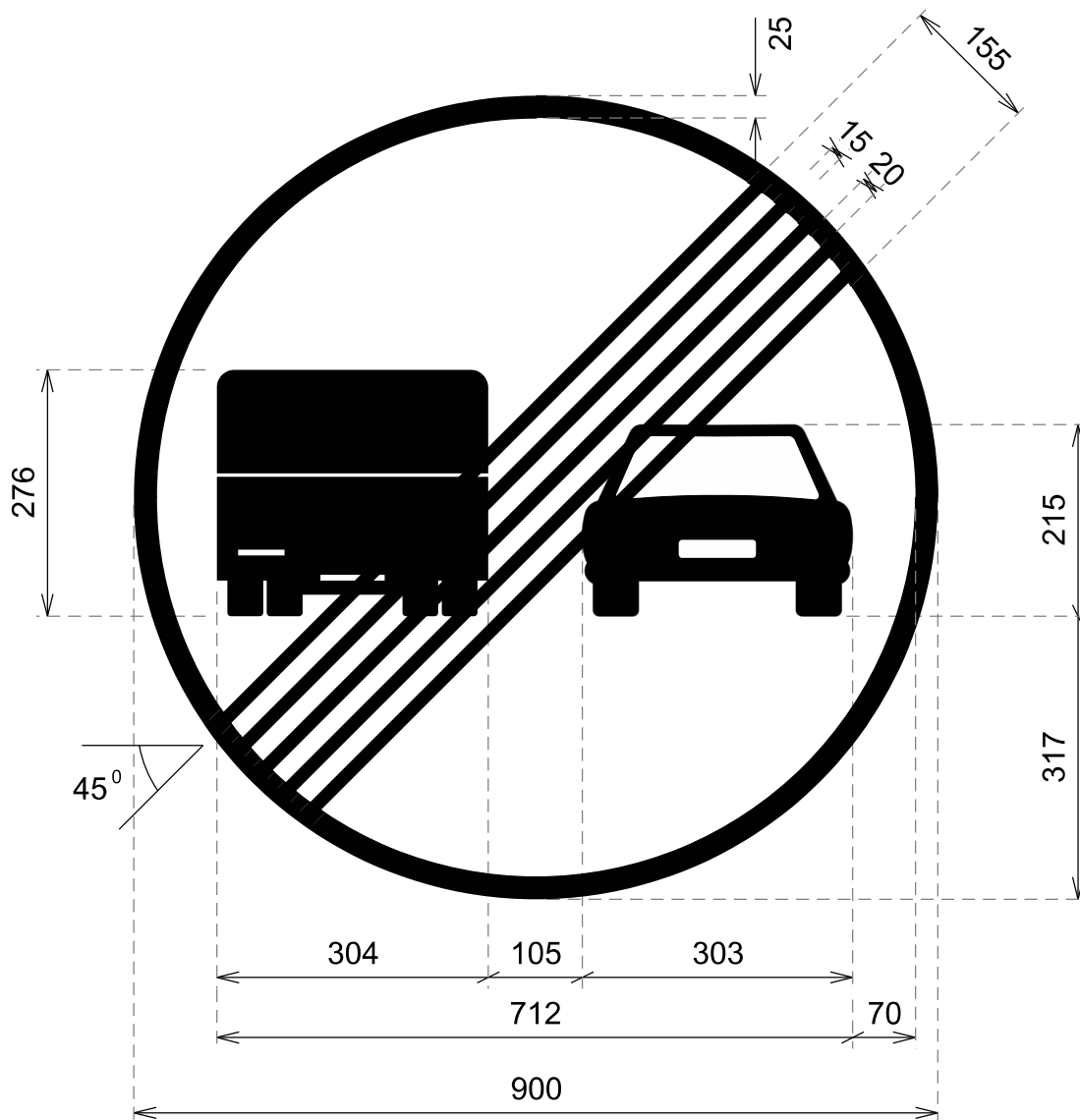

cotas en mm

Fin de la prohibición de adelantamiento para camiones

**R-503**

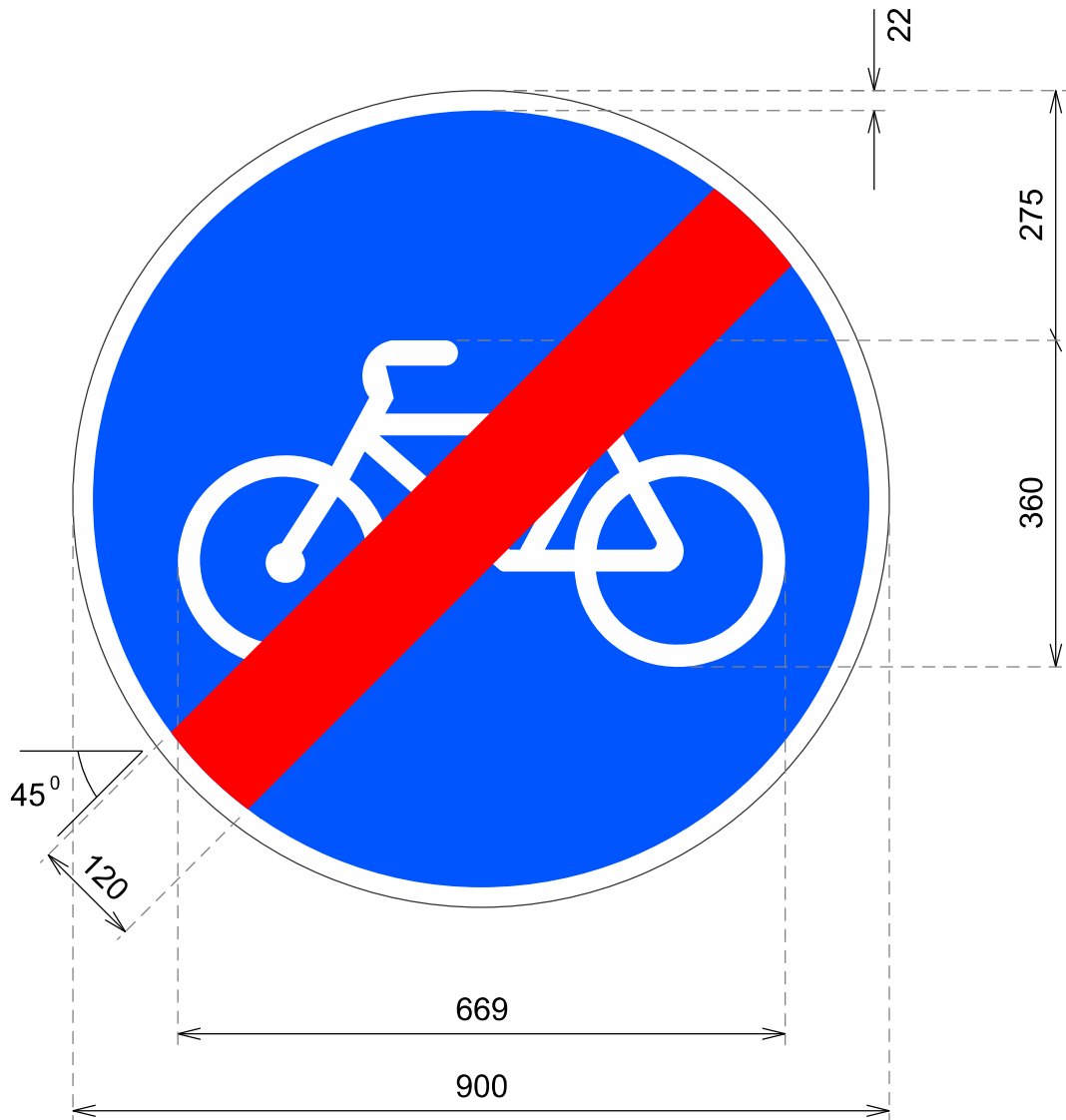

cotas en mm

Fin de vía reservada y obligatoria para ciclos

**R-505**



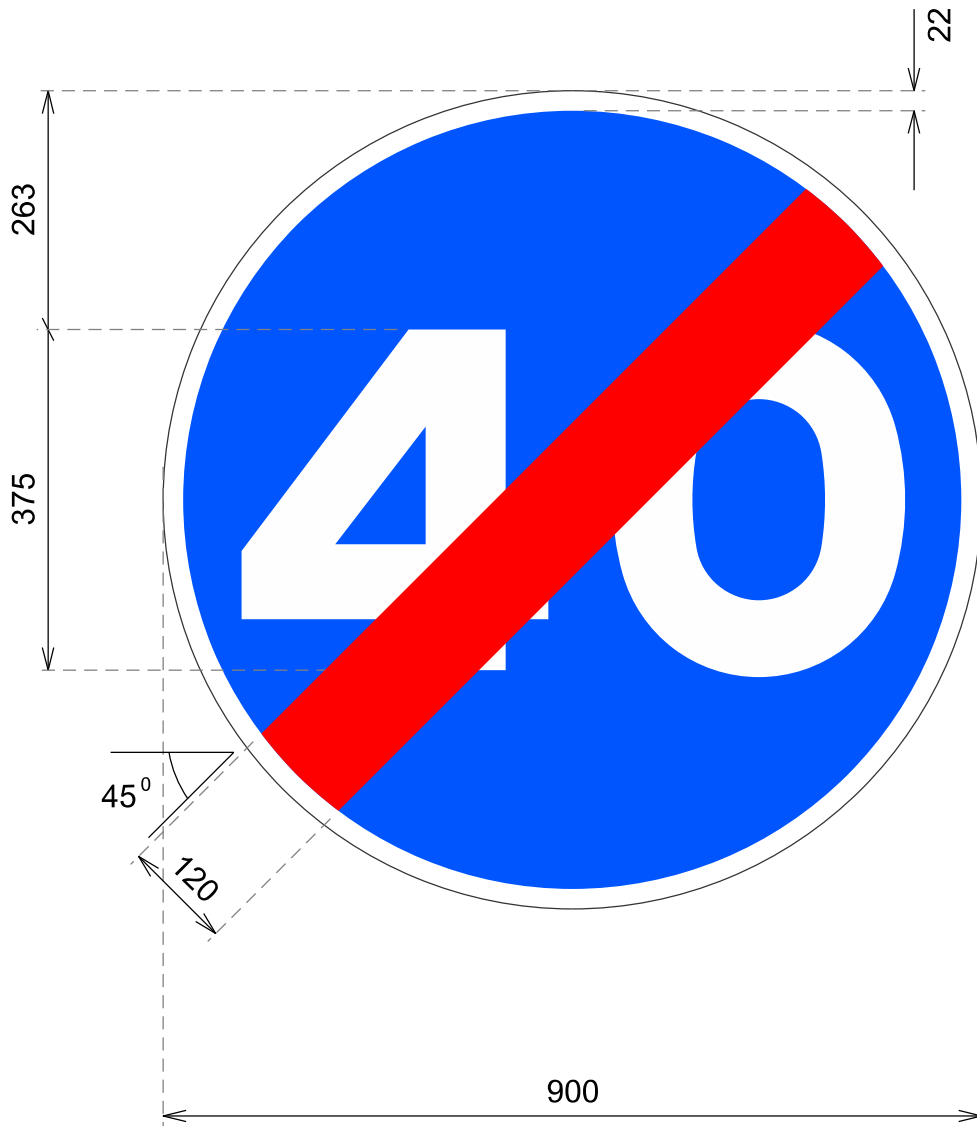

cotas en mm

Fin de velocidad mínima

**R-506**

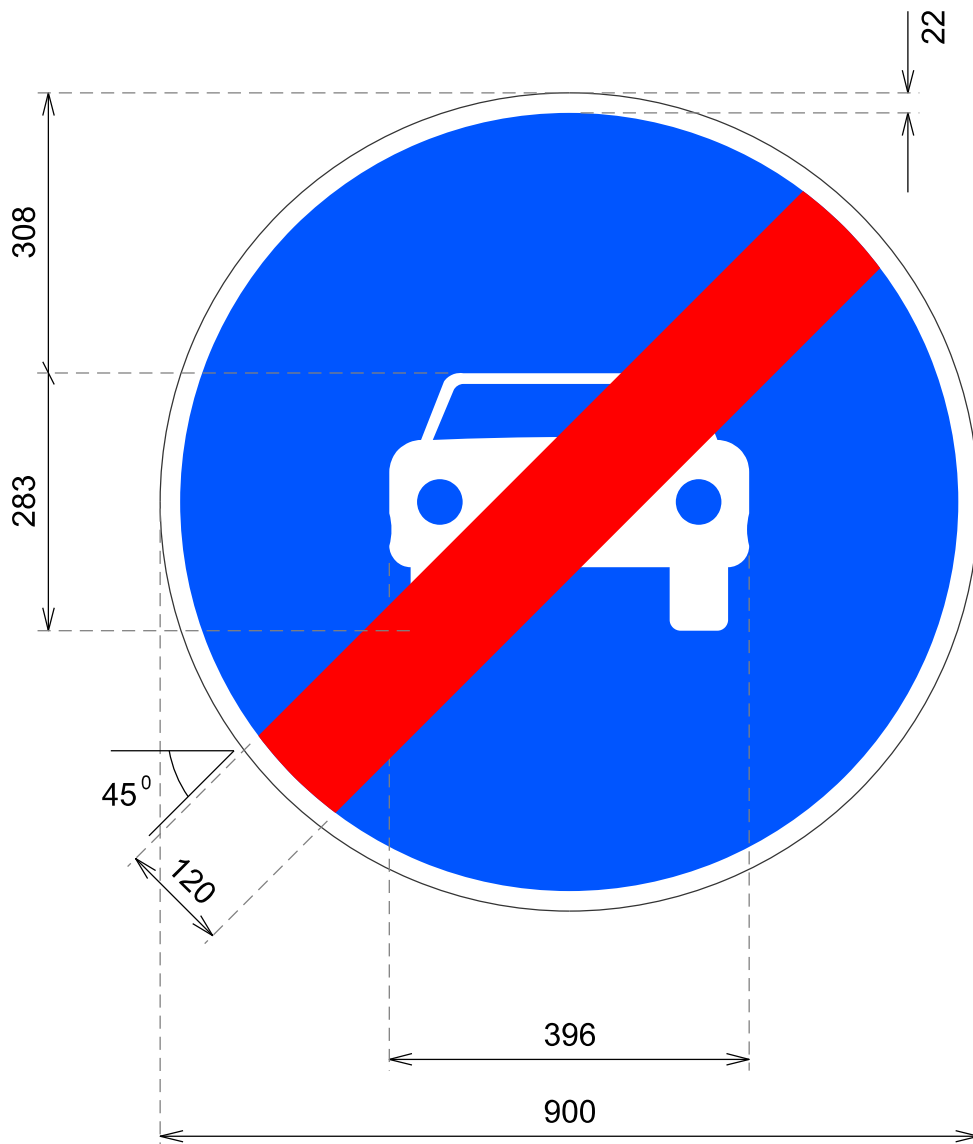

cotas en mm

Fin de calzada obligatoria para automóviles, excepto  
motocicletas de dos ruedas

**R-507**

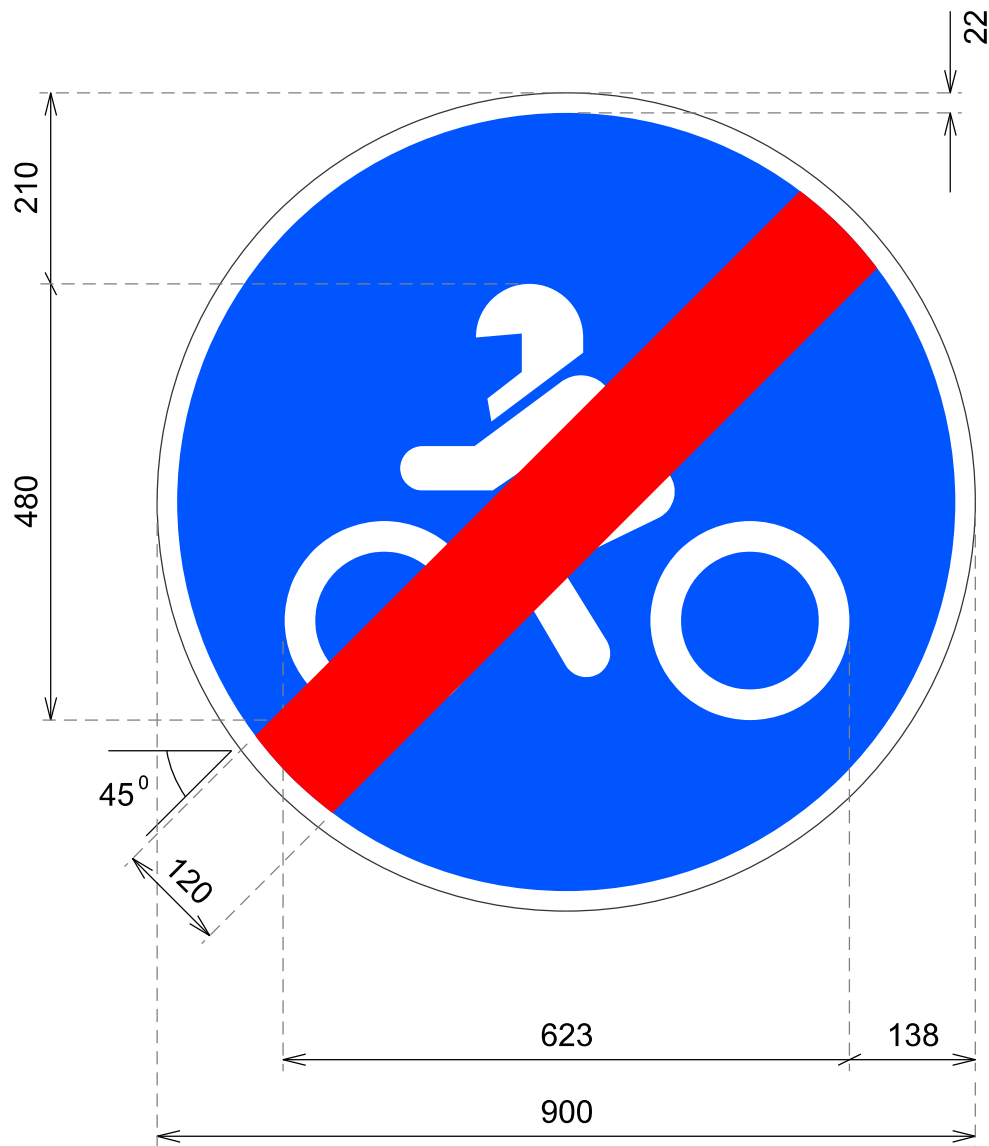

cotas en mm

Fin de calzada obligatoria para motocicletas de dos ruedas

**R-508**

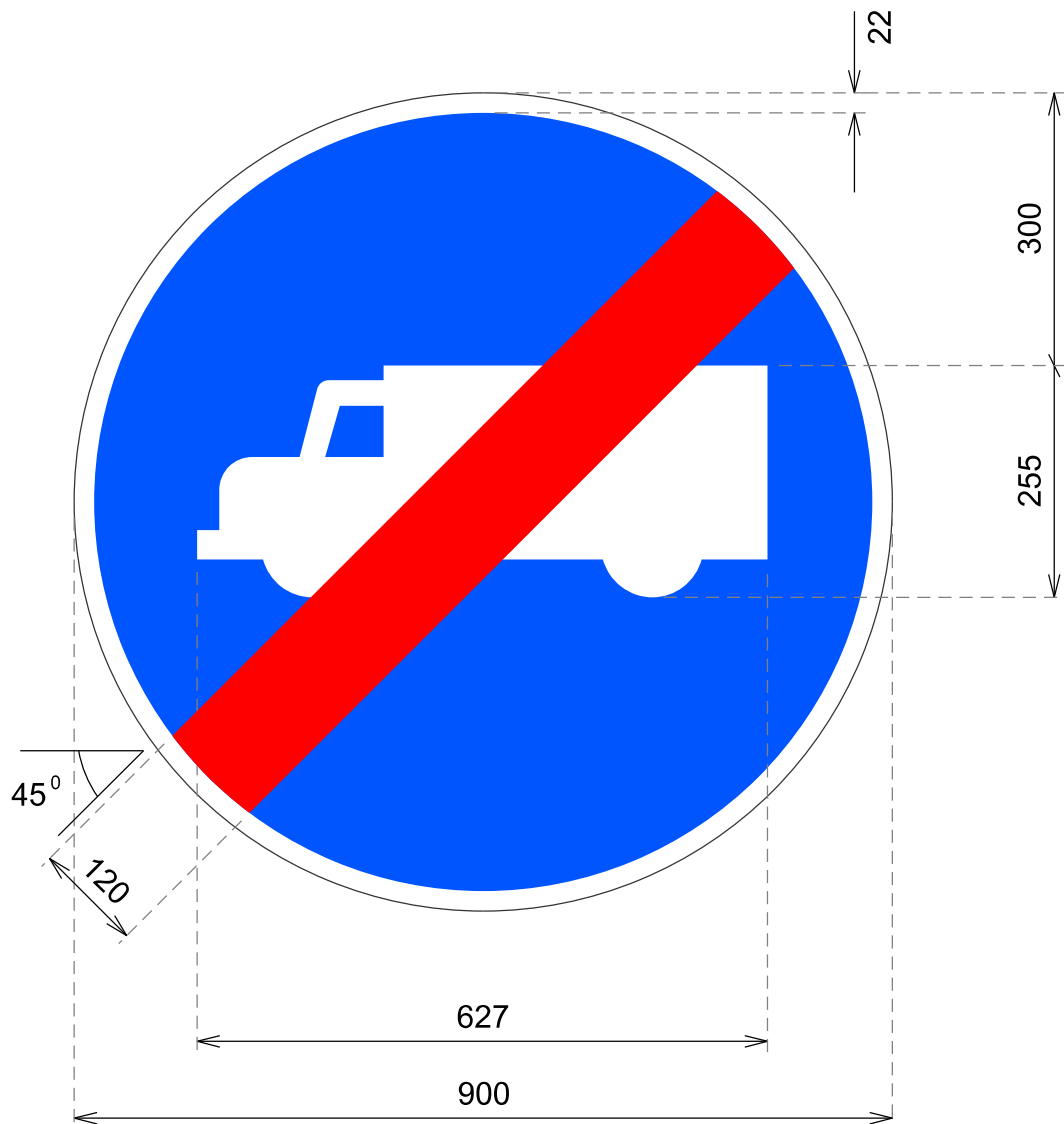

cotas en mm

Fin de calzada obligatoria para camiones,  
tractocamiones y furgones o furgonetas

**R-509**

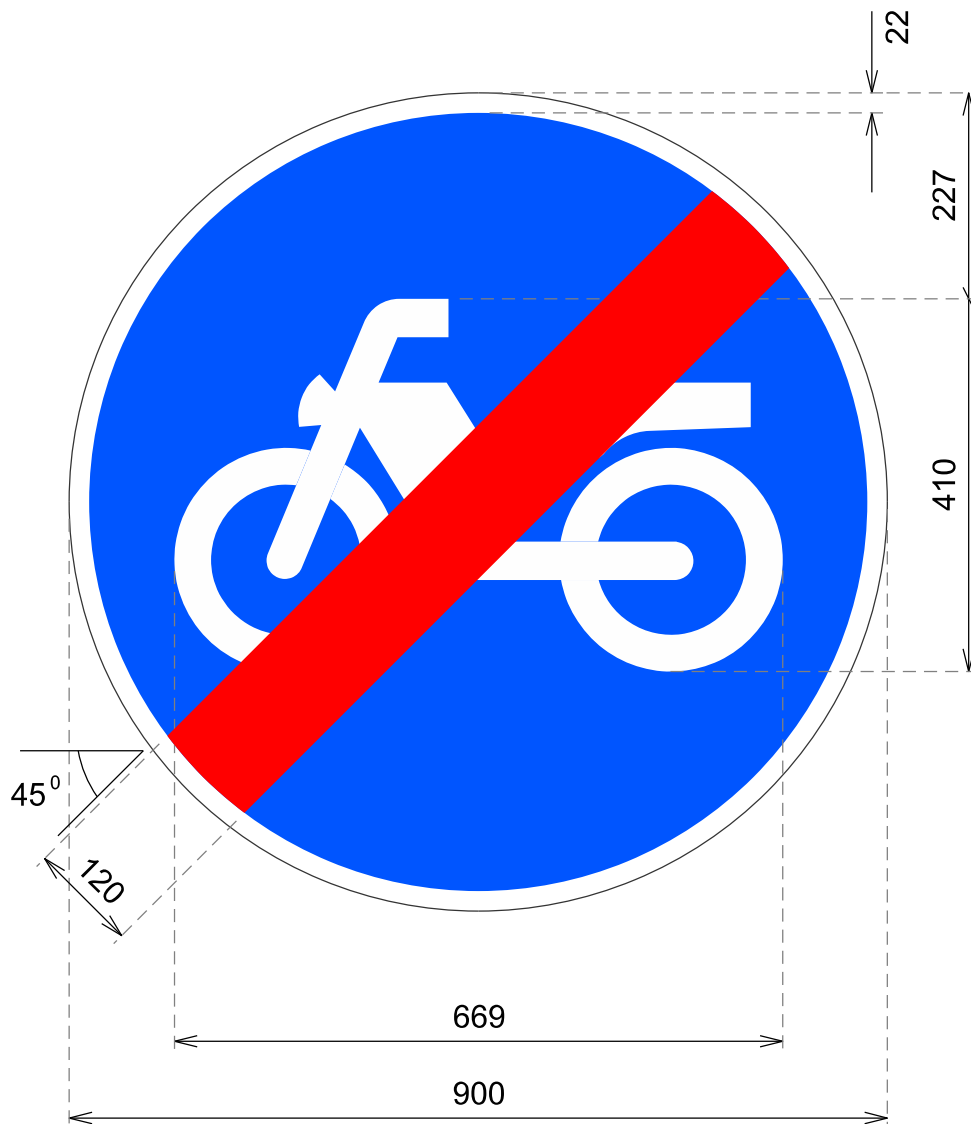

cotas en mm

Fin de vía reservada y obligatoria para ciclomotores

**R-510**

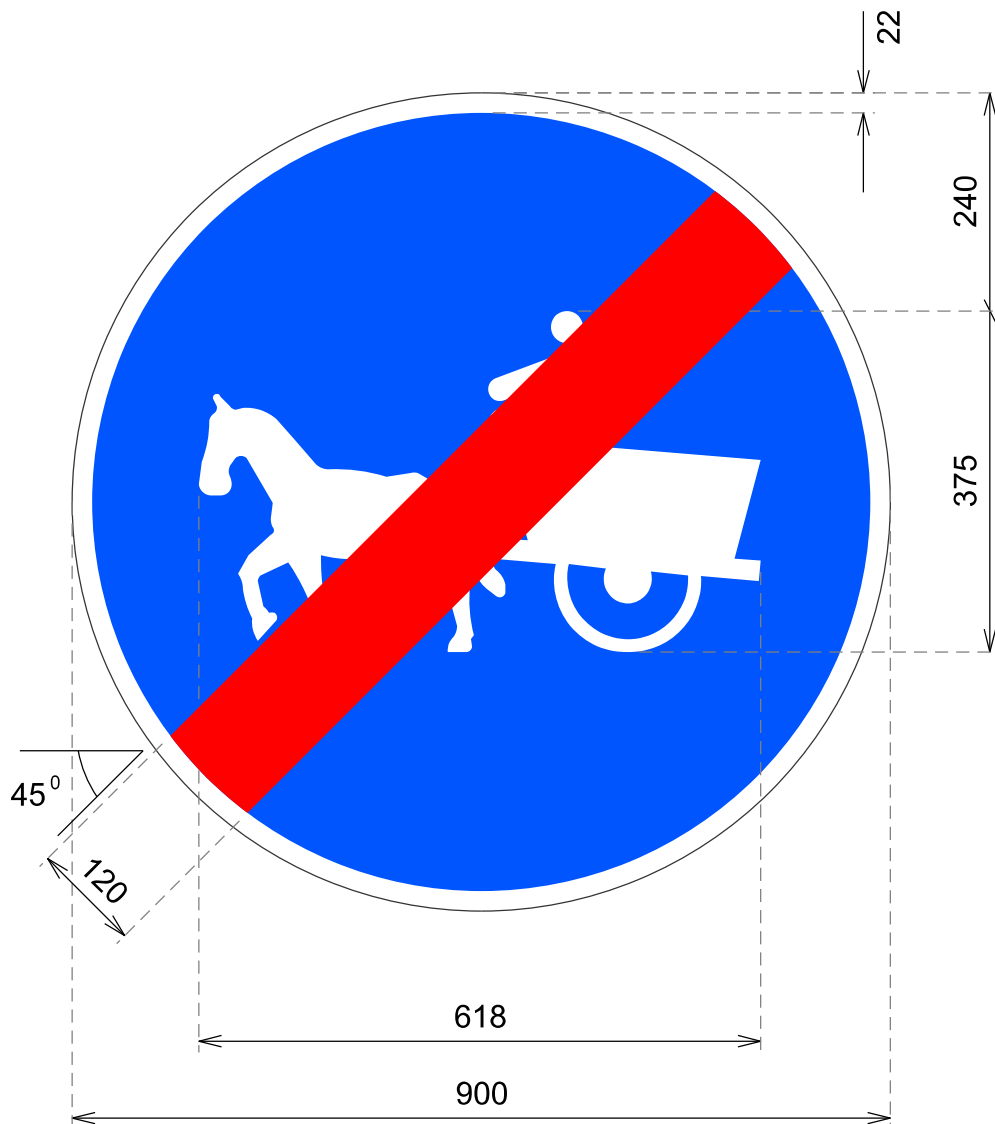

cotas en mm

Fin de camino obligatorio para vehículos de  
tracción animal

**R-511**



# SEÑALES DE REGLAMENTACIÓN

## FIN DE PROHIBICIÓN, RESTRICCIÓN U OBLIGACIÓN

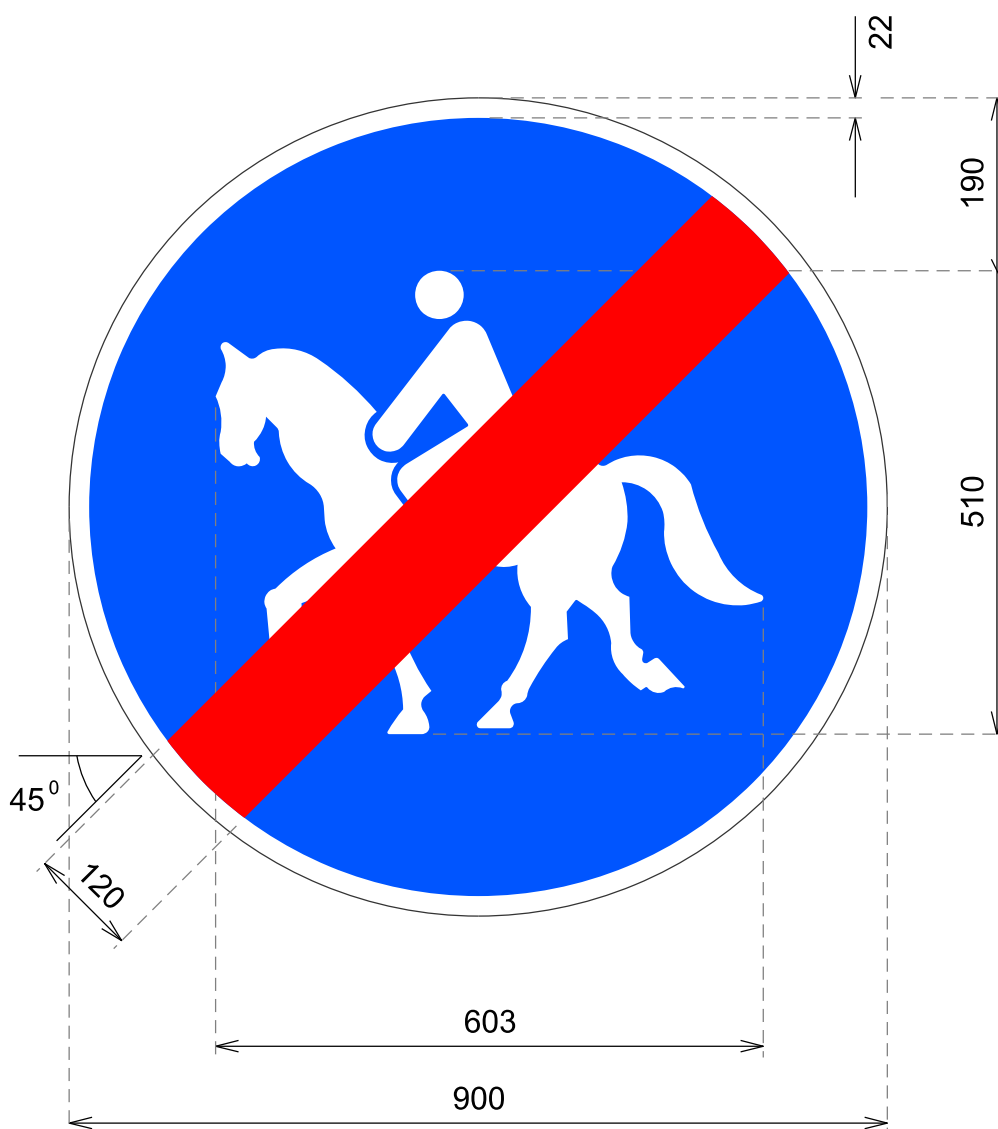

cotas en mm

Fin de camino reservado y obligatorio para animales de montura

**R-512**

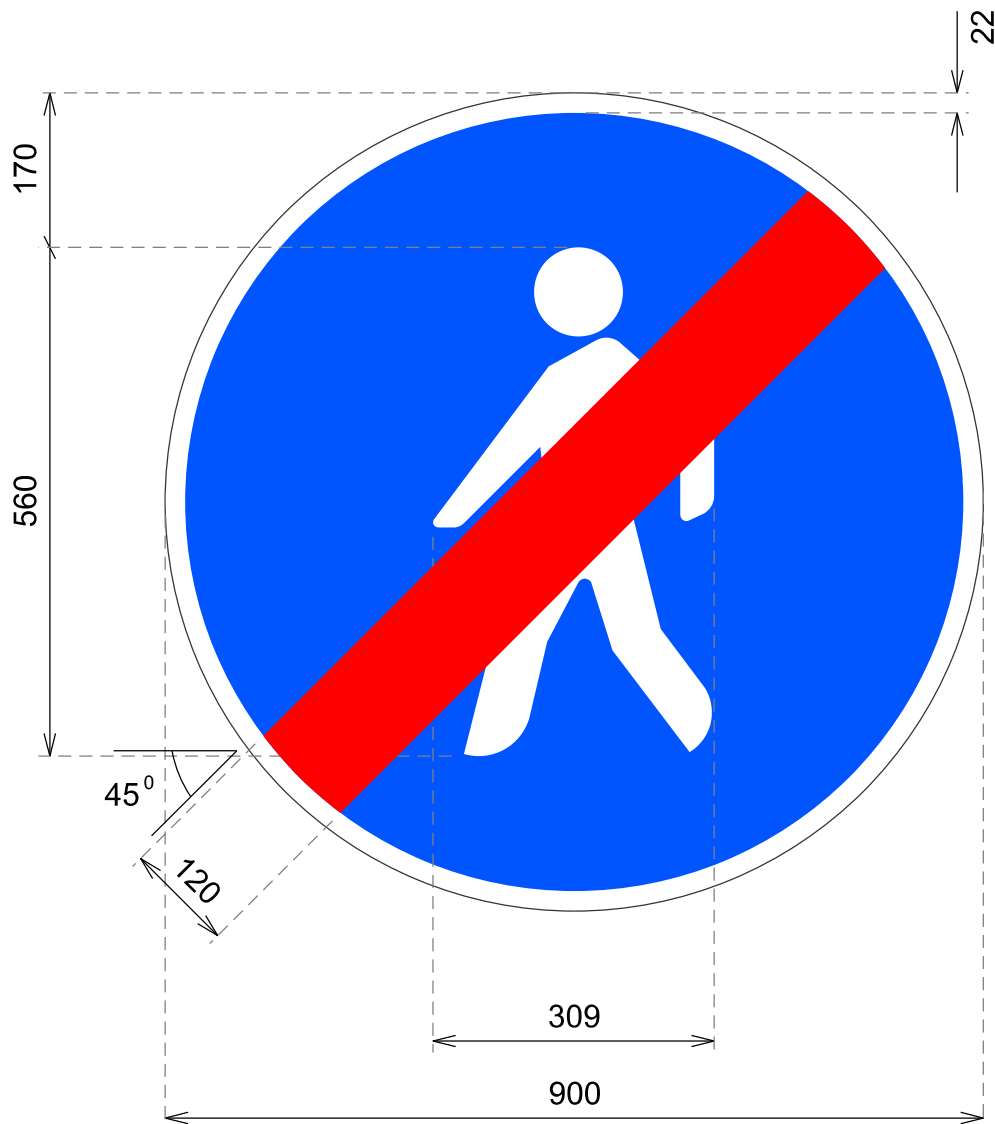

cotas en mm

Fin de camino reservado y obligatorio para peatones

**R-513**



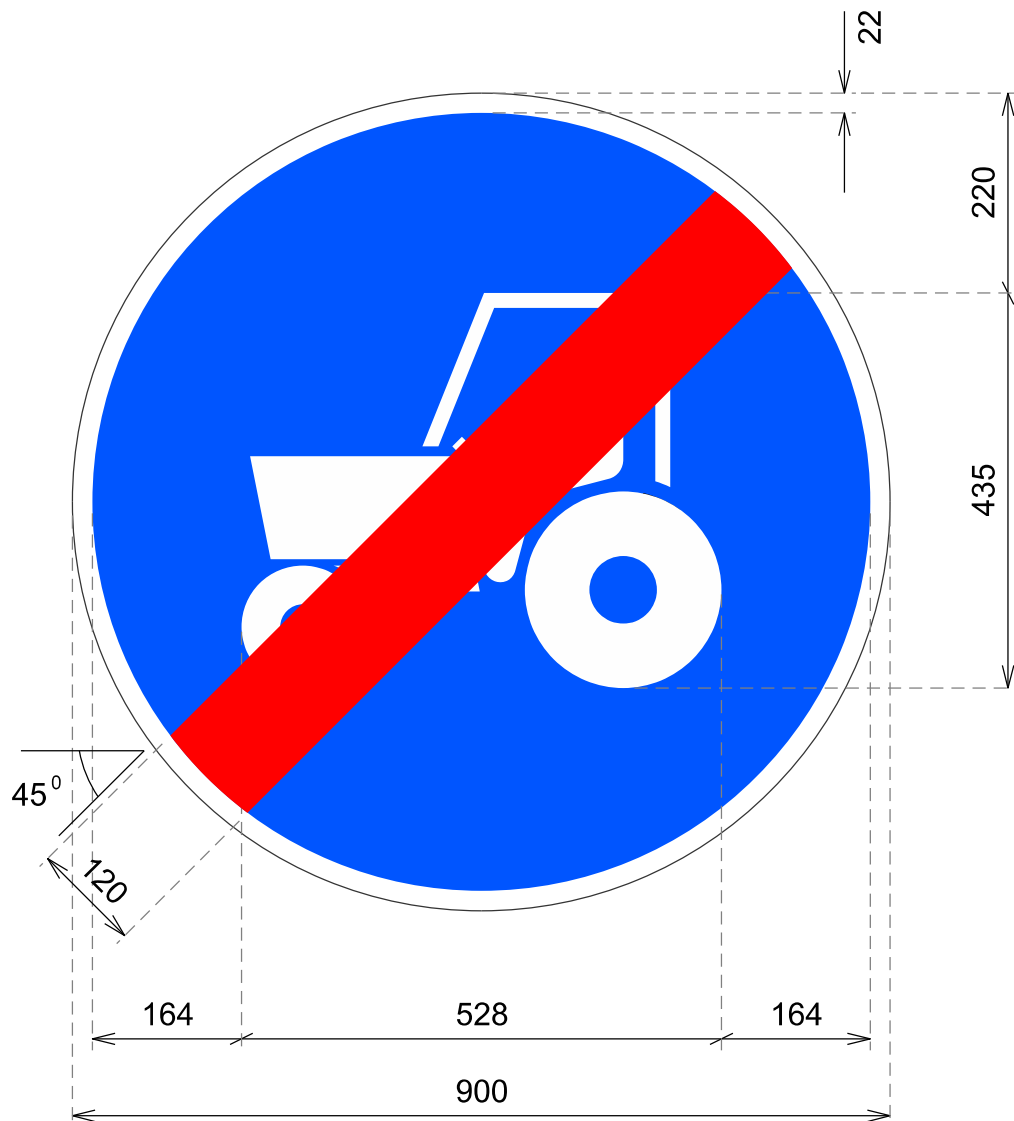

cotas en mm

Fin de camino obligatorio para tractores

**R-514**

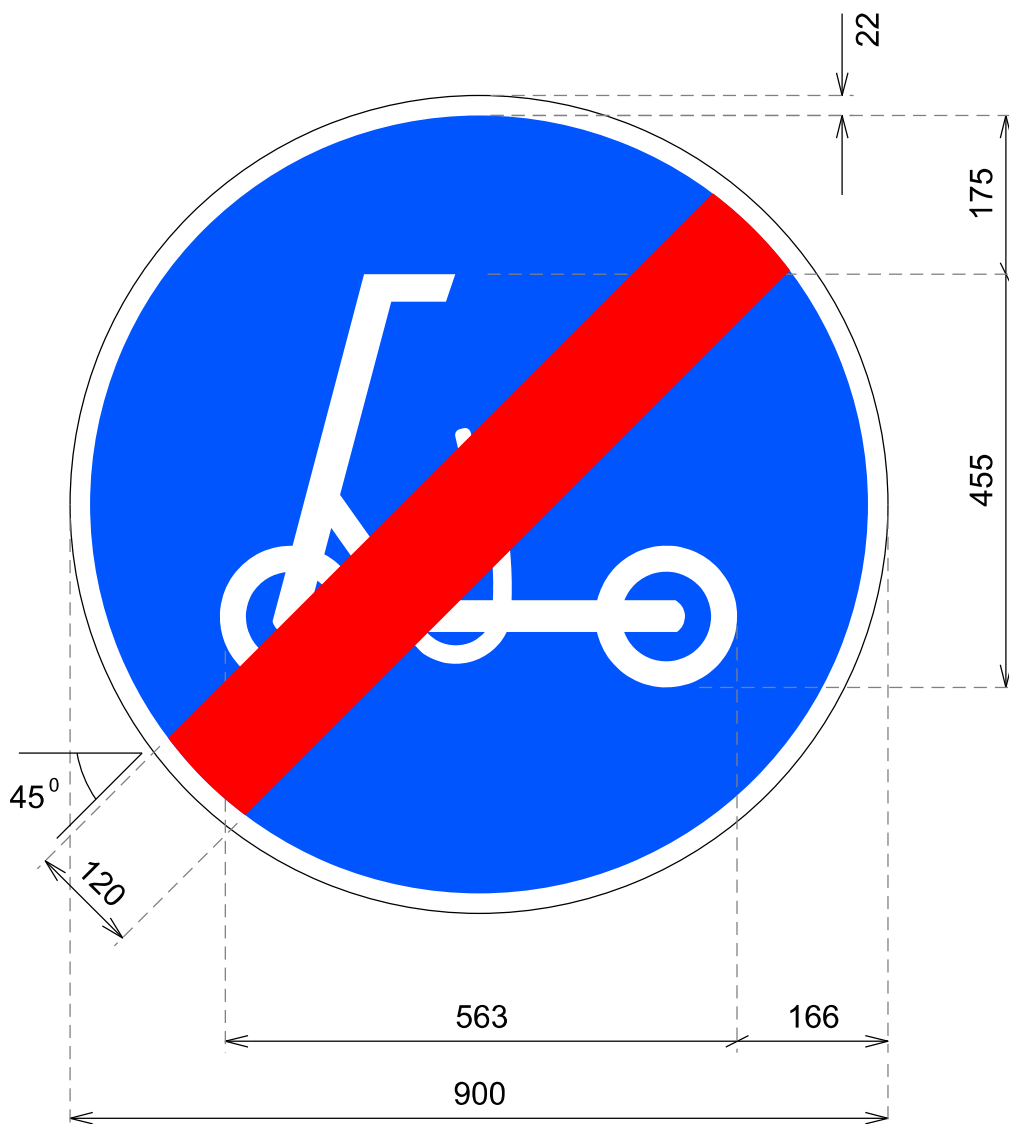

cotas en mm

Fin de vía reservada y obligatoria para  
vehículos de movilidad personal

**R-515**

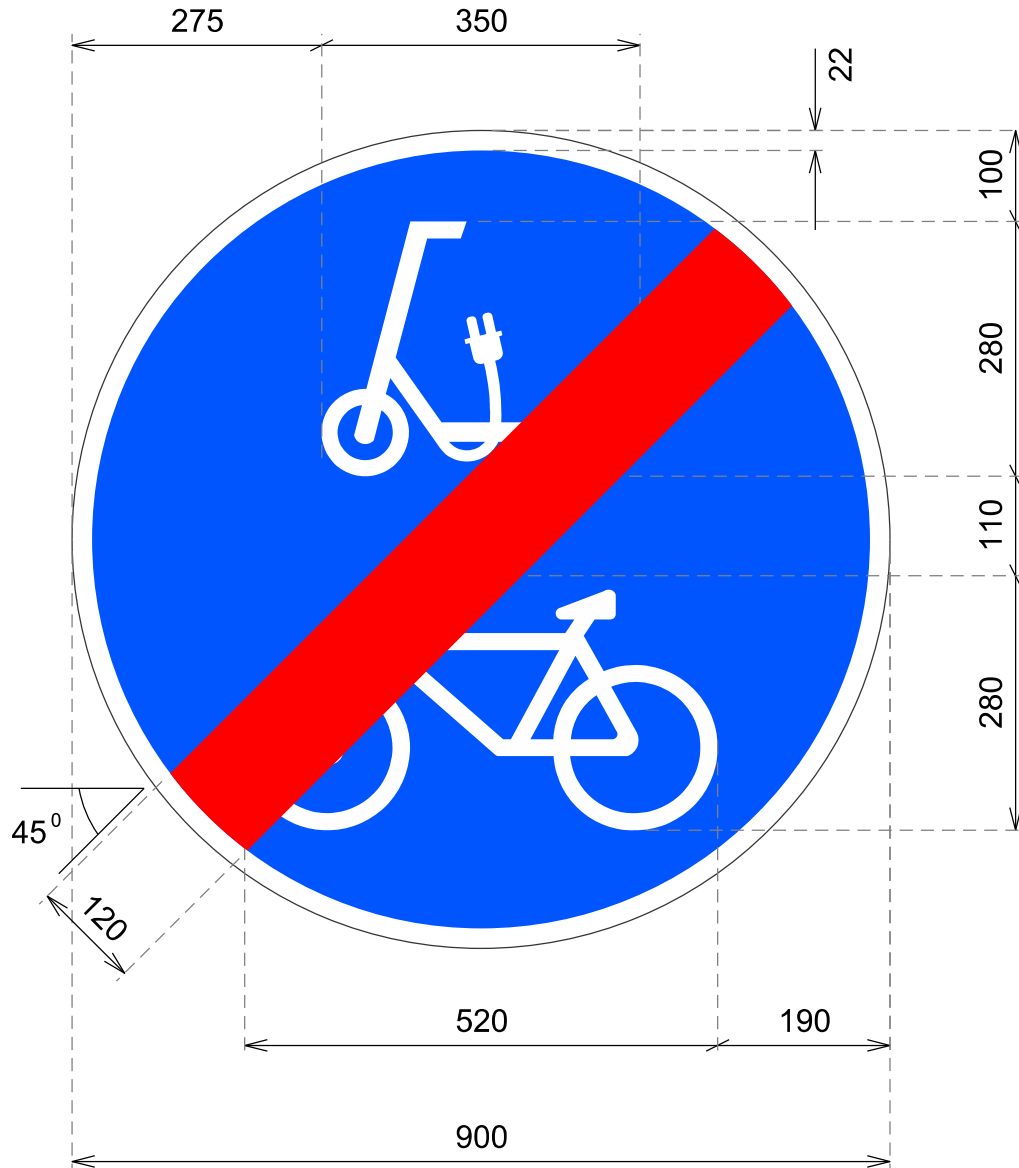

cotas en mm

Fin de vía reservada y obligatoria para ciclos y para vehículos de movilidad personal

**R-516**

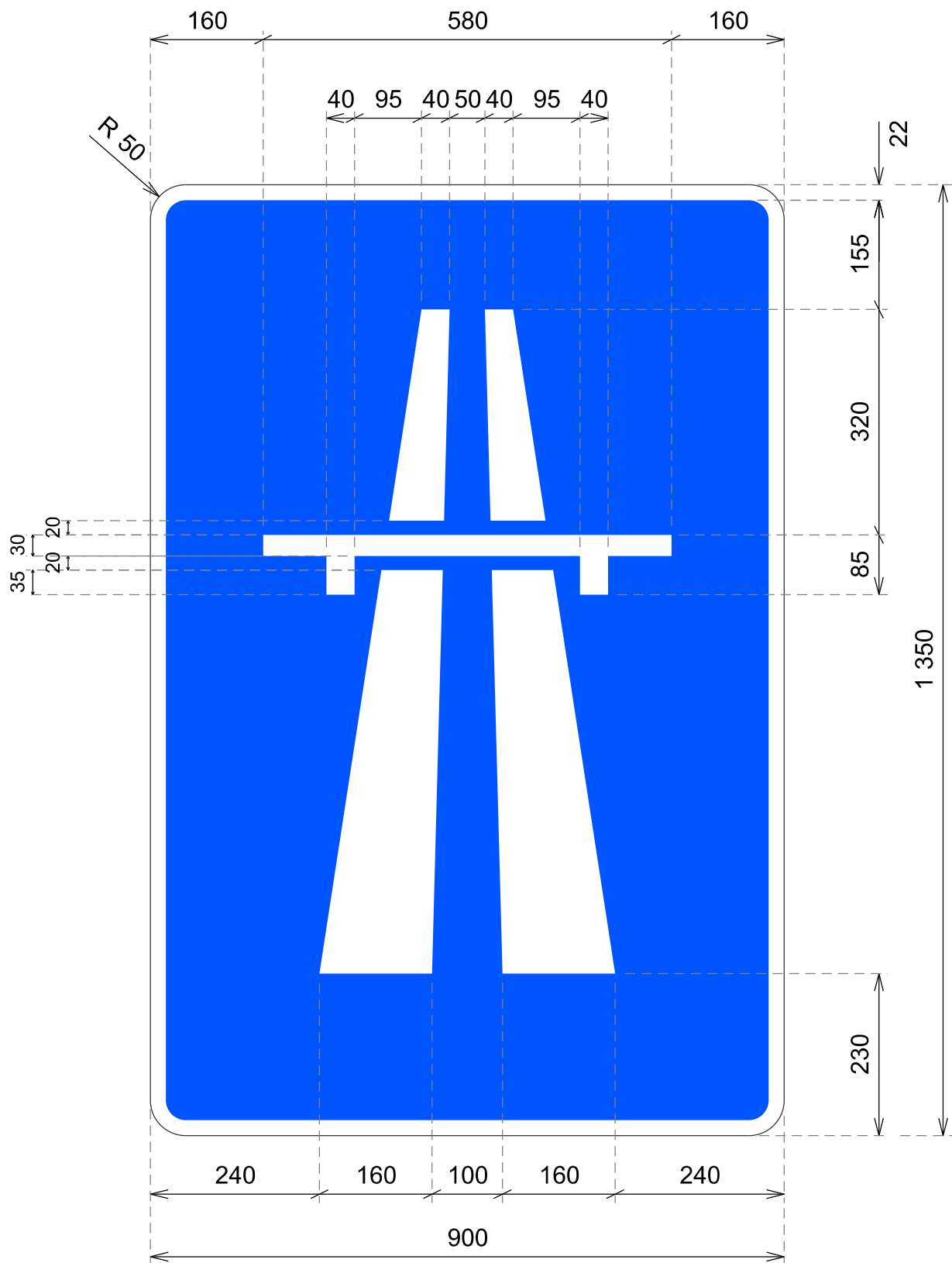

cotas en mm

Autopista

S-1

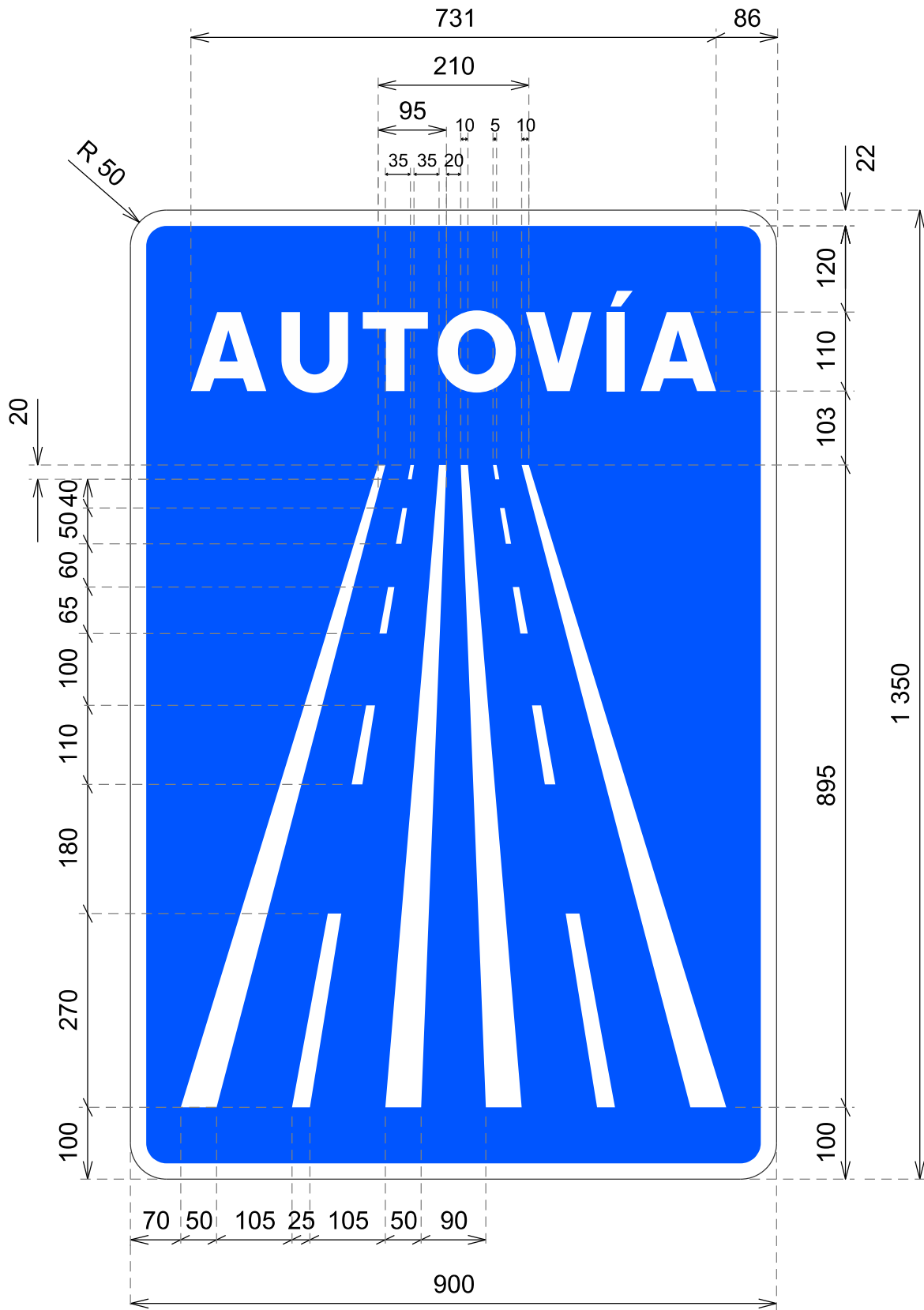

cotas en mm

Autovía

S-1a



cotas en mm

Carretera multicarril

S-1b

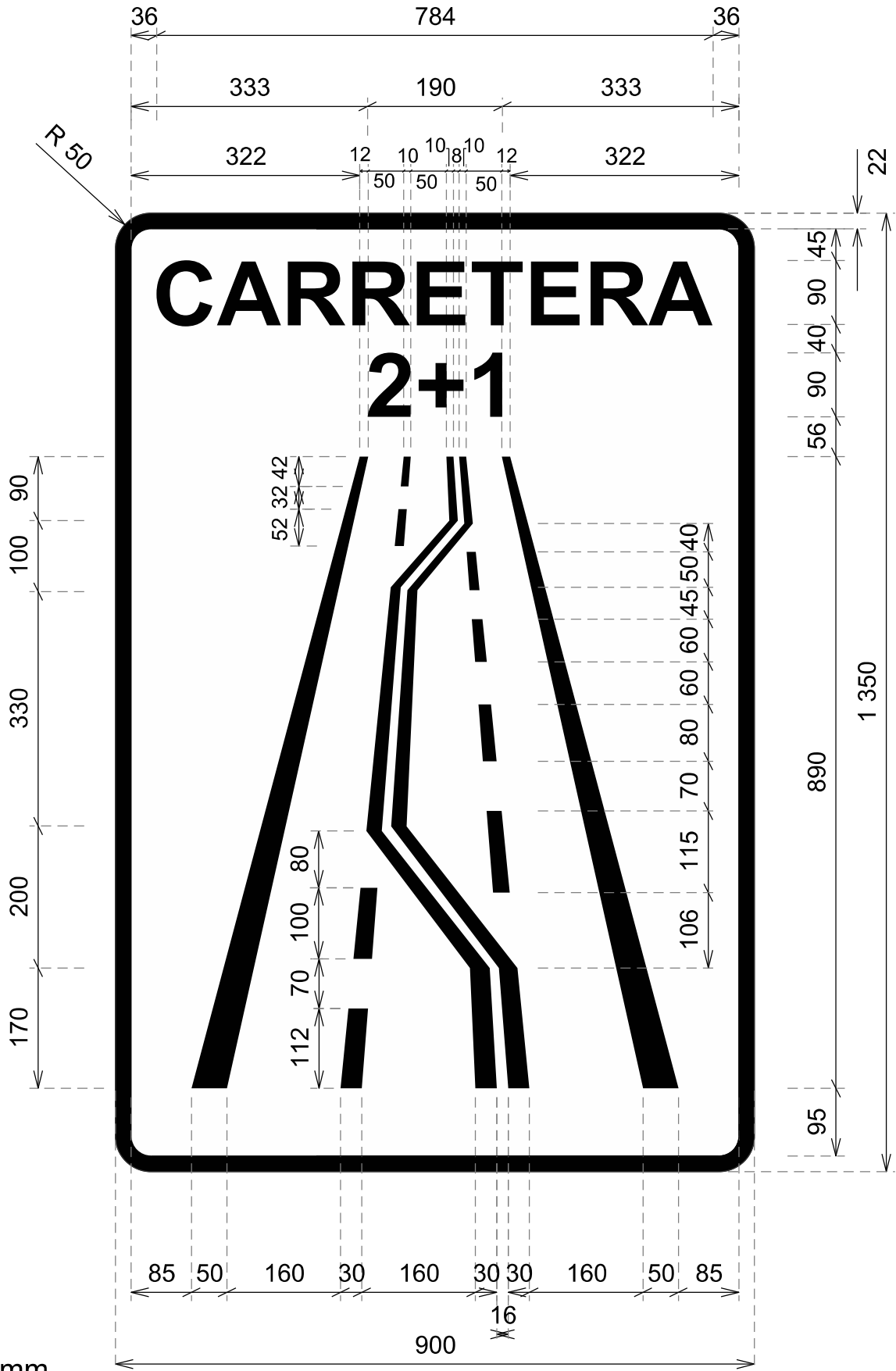

cotas en mm

Carretera 2+1

S-1c

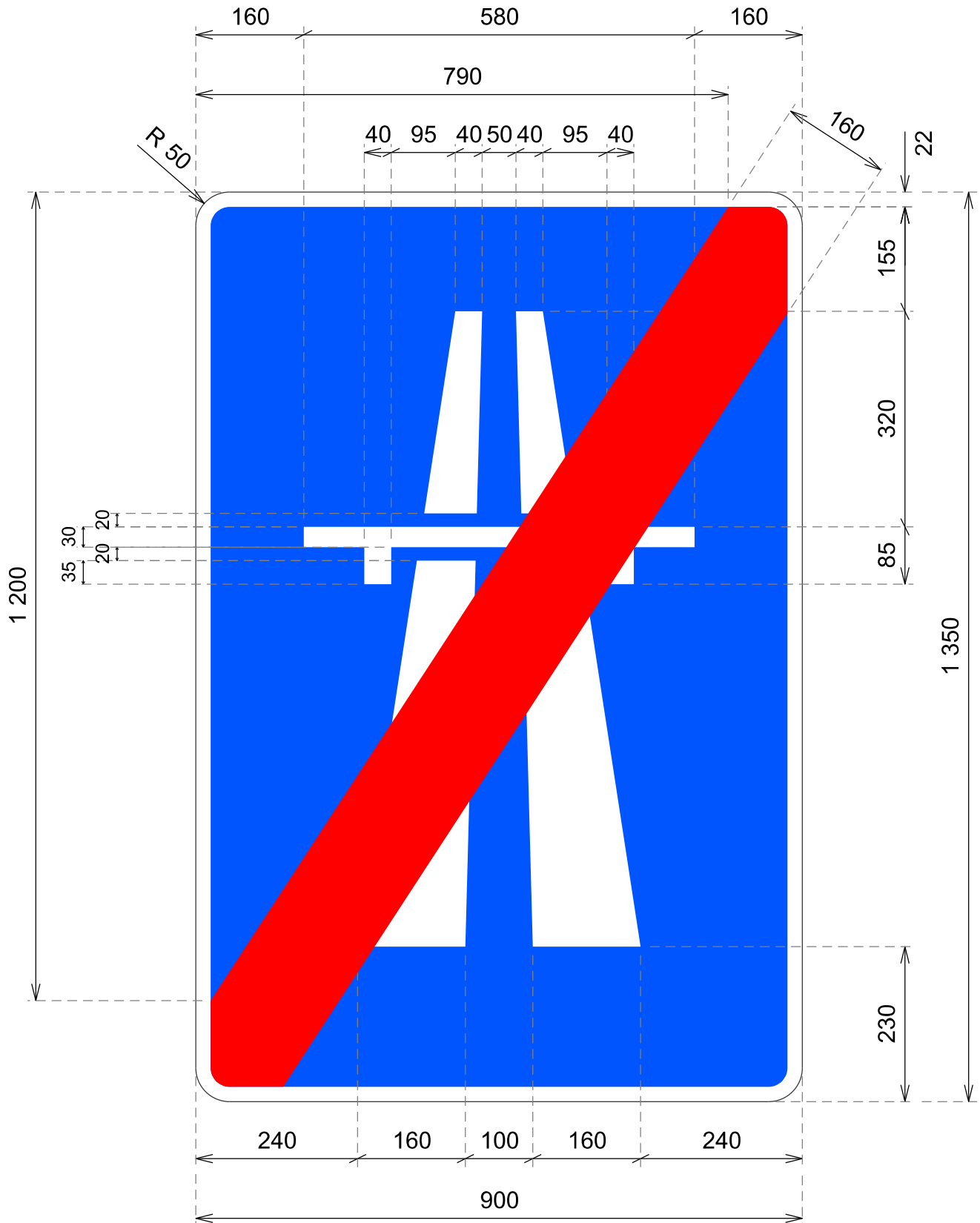

cotas en mm

Fin de autopista

S-2



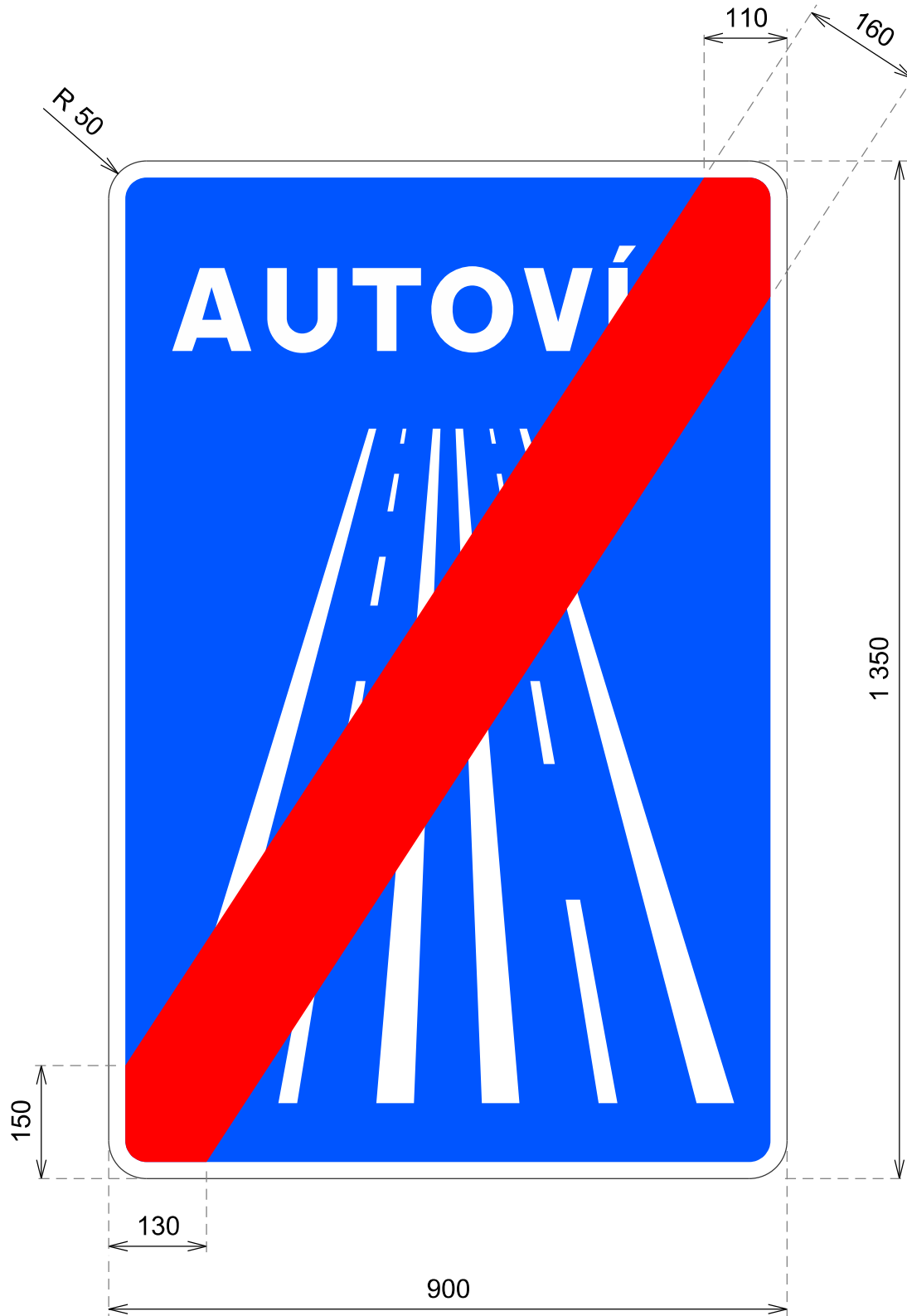

cotas en mm

Fin de autovía

S-2a



cotas en mm

Fin de carretera multicarril

S-2b

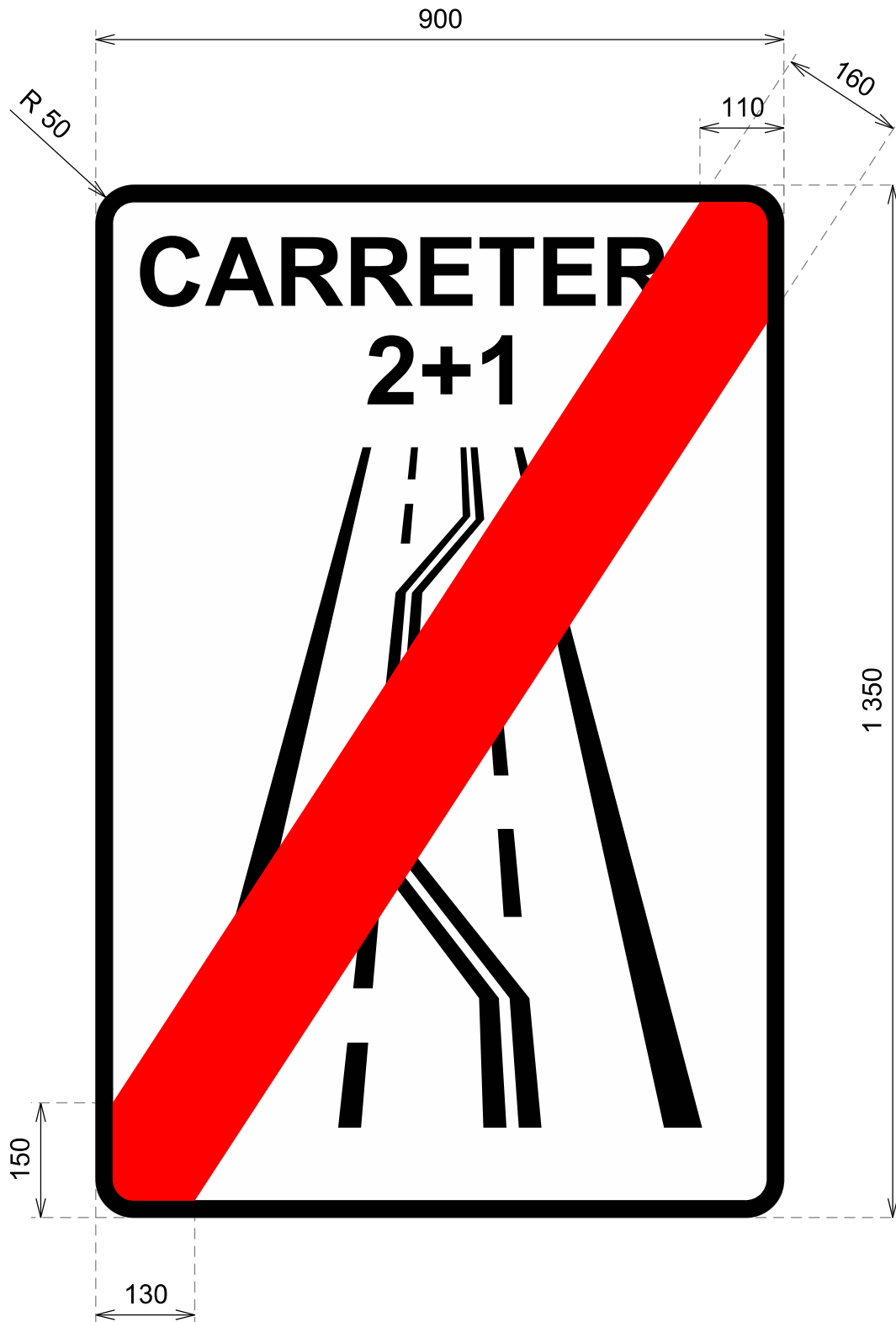

cotas en mm

Fin de carretera 2+1

S-2c

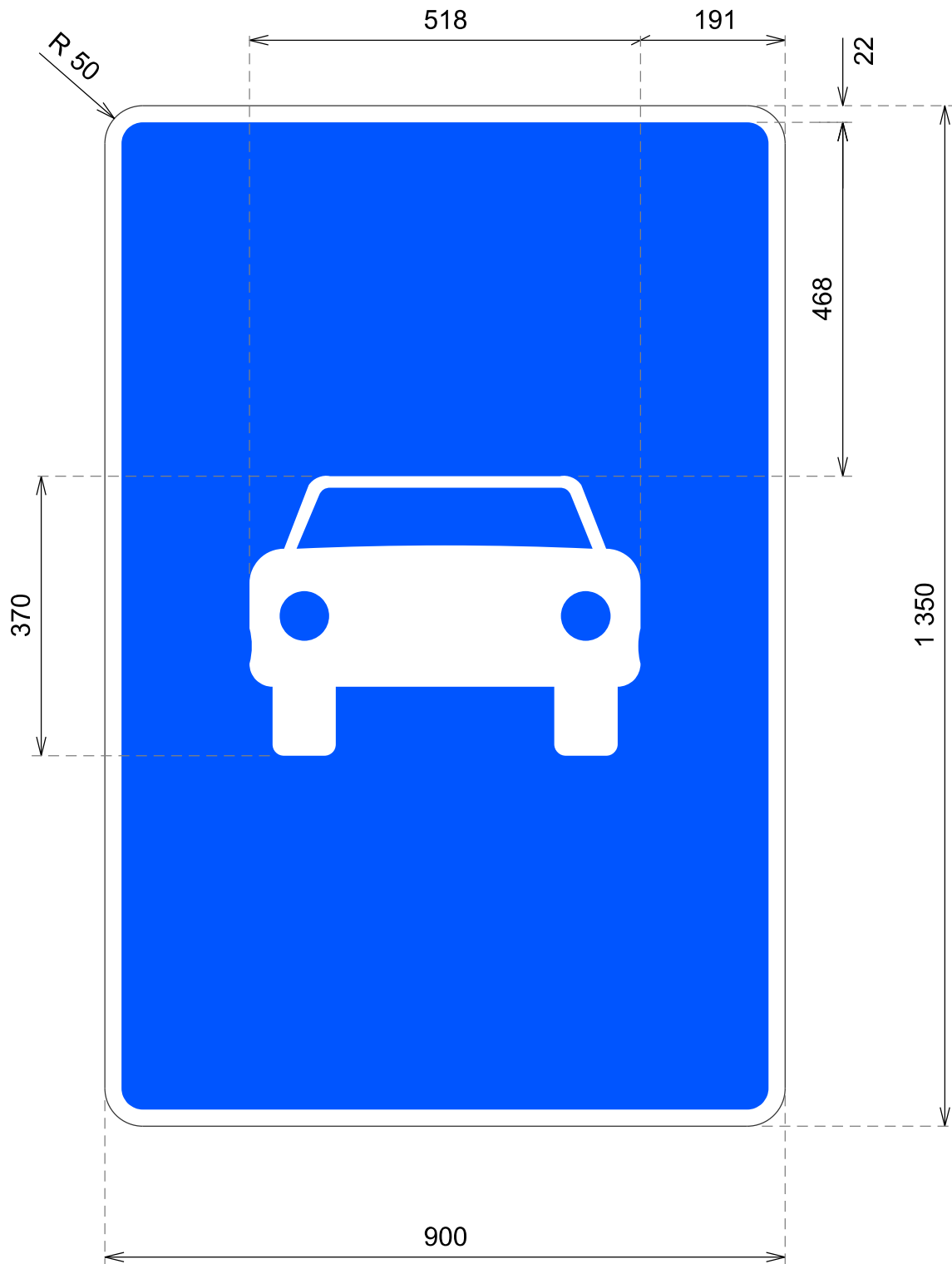

cotas en mm

Vía reservada para automóviles

S-3

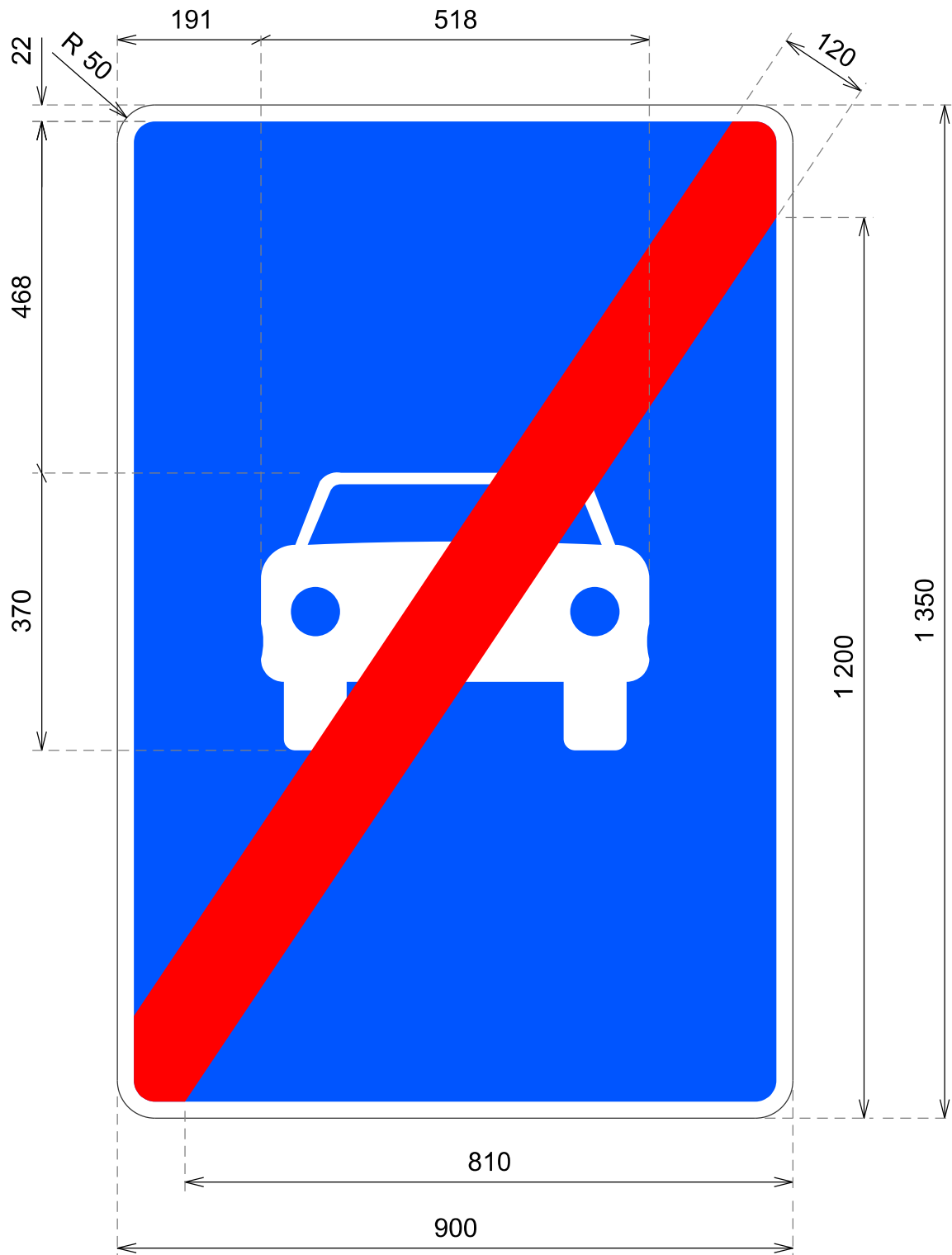

cotas en mm

Fin de vía reservada para automóviles

S-4

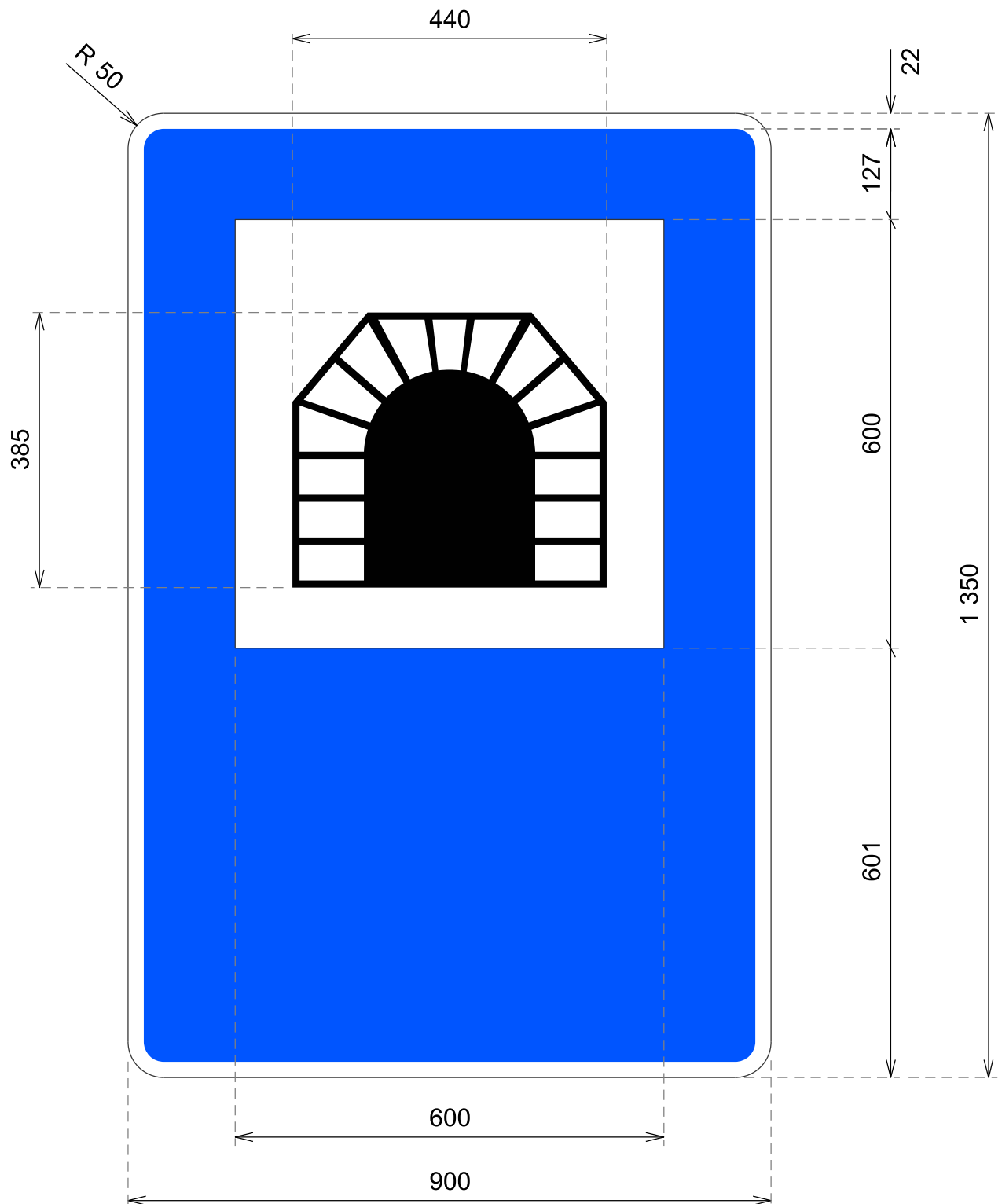

cotas en mm

Túnel

S-5

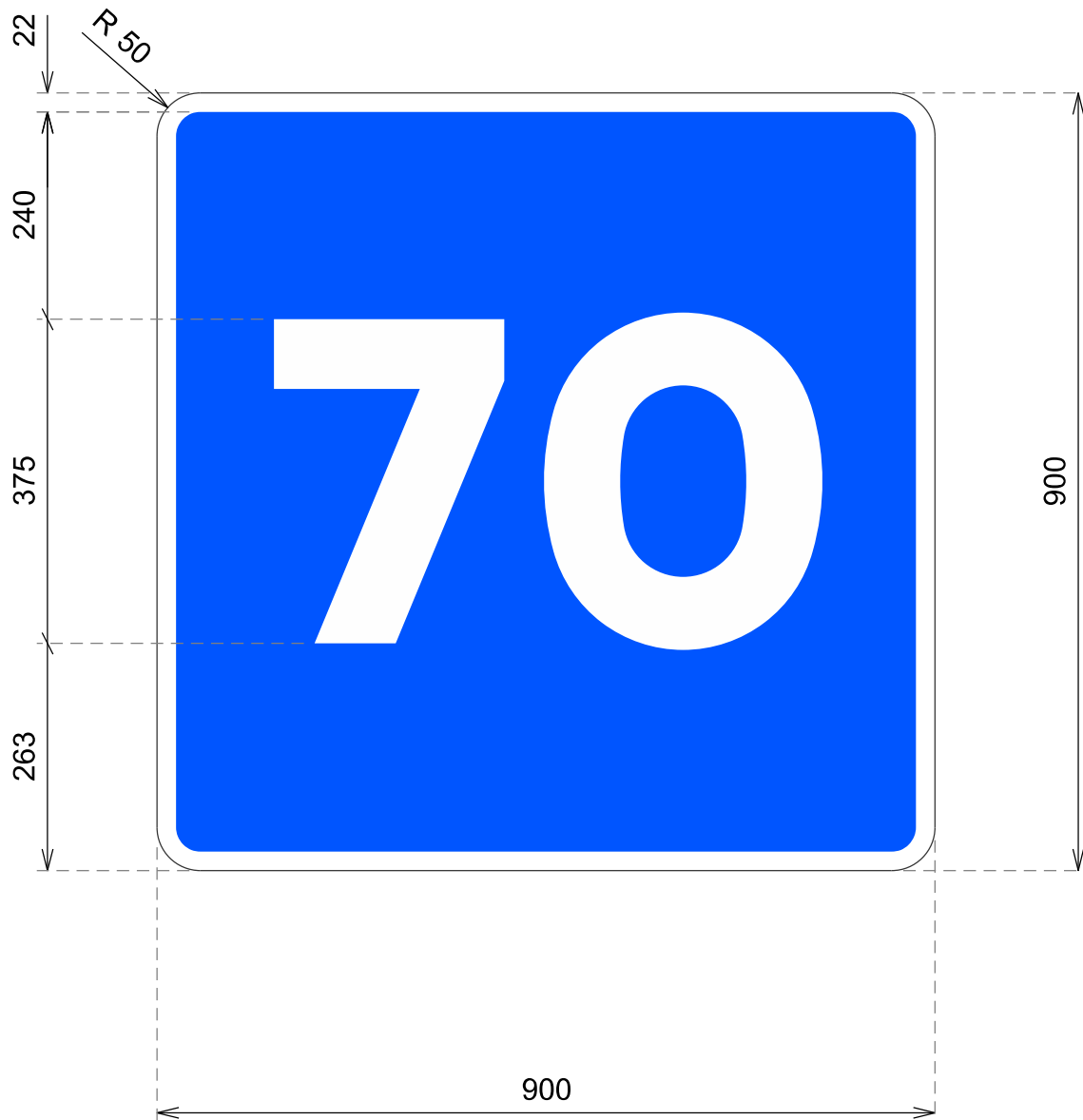

cotas en mm

Velocidad máxima aconsejada

S-7

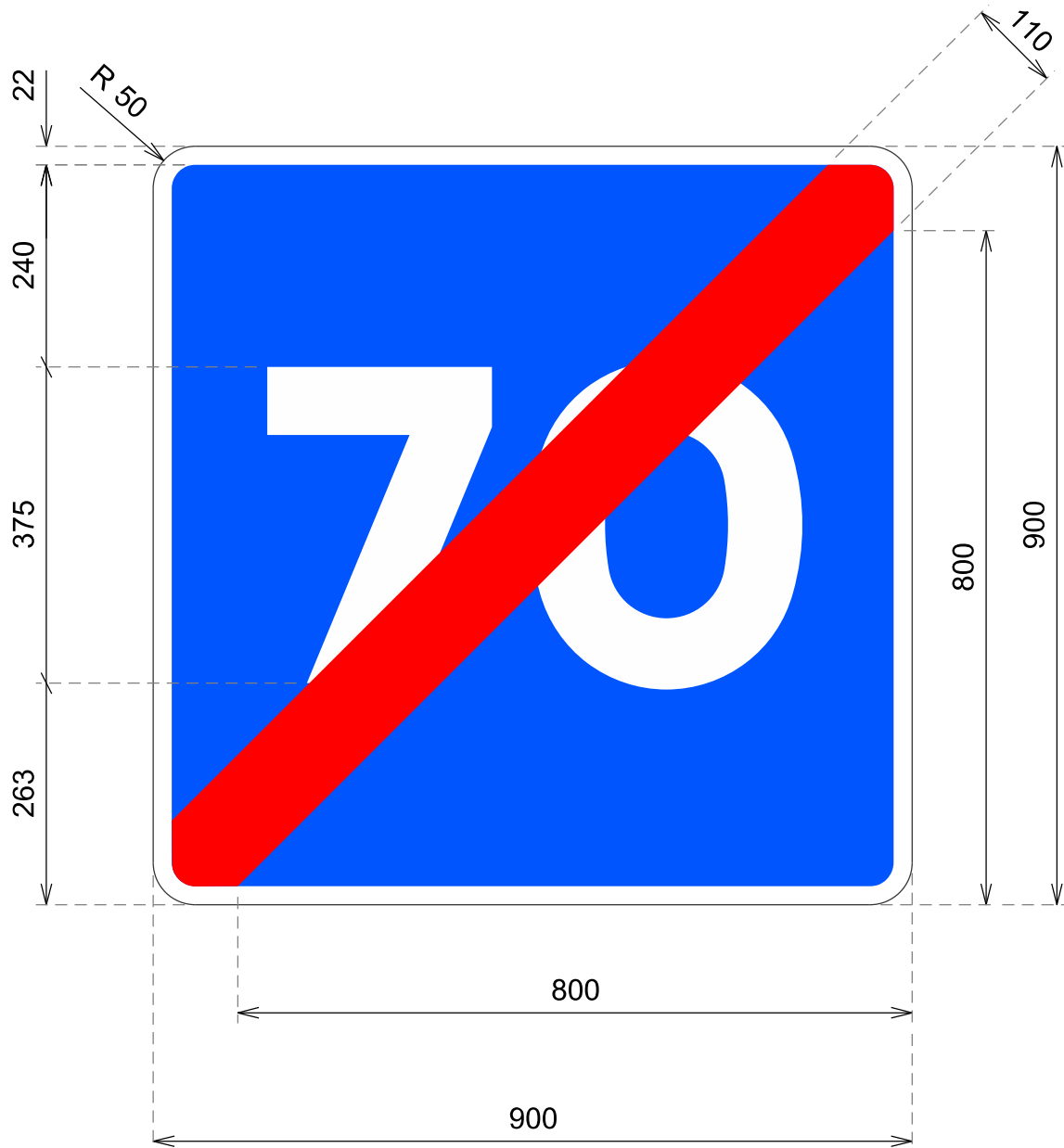

cotas en mm

Fin de velocidad máxima aconsejada

S-8



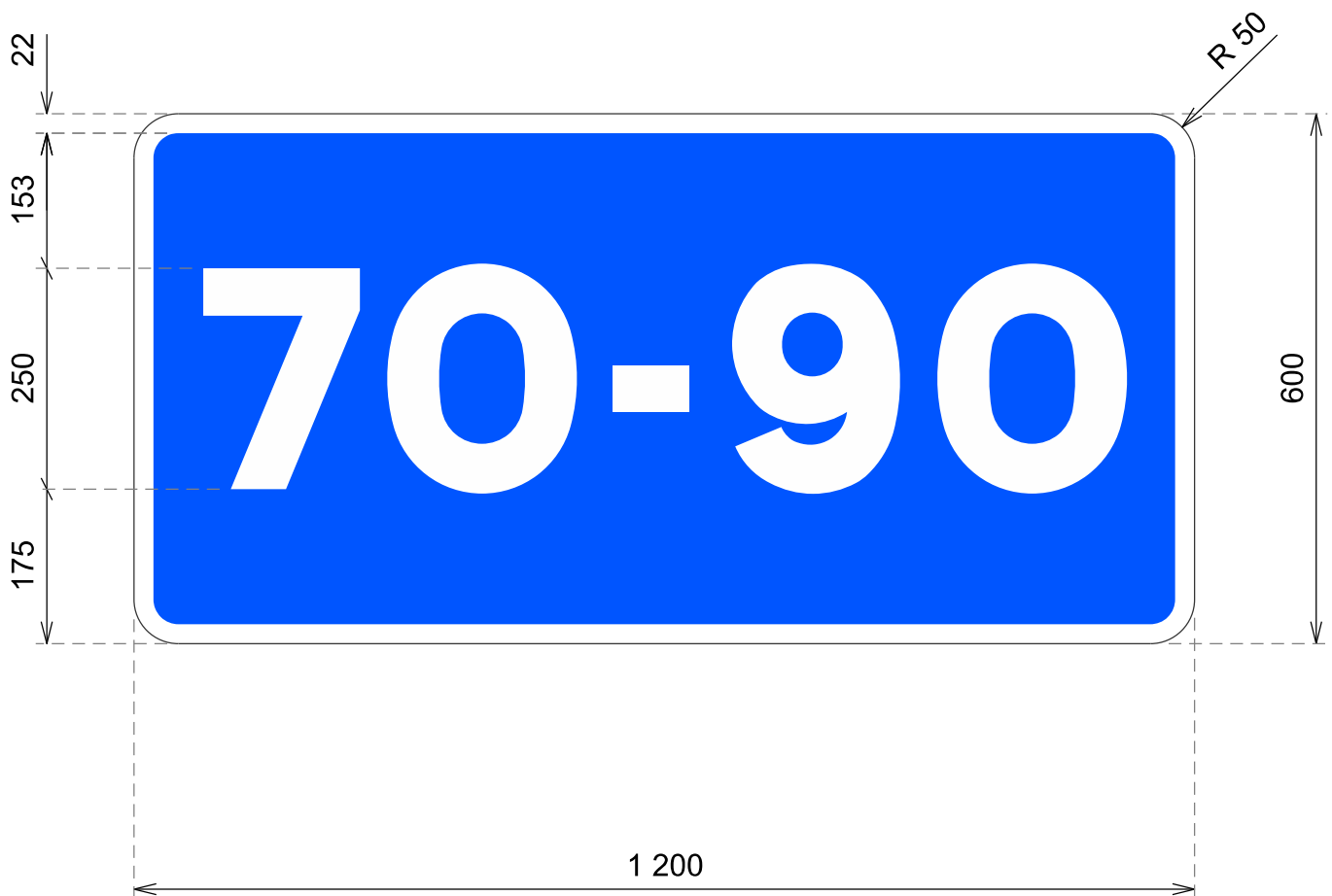

cotas en mm

tamaño para autopista y autovía: 1600 x 800

tamaño para carretera convencional sin arcén: 800 x 400

Intervalo aconsejado de velocidades

**S-9**

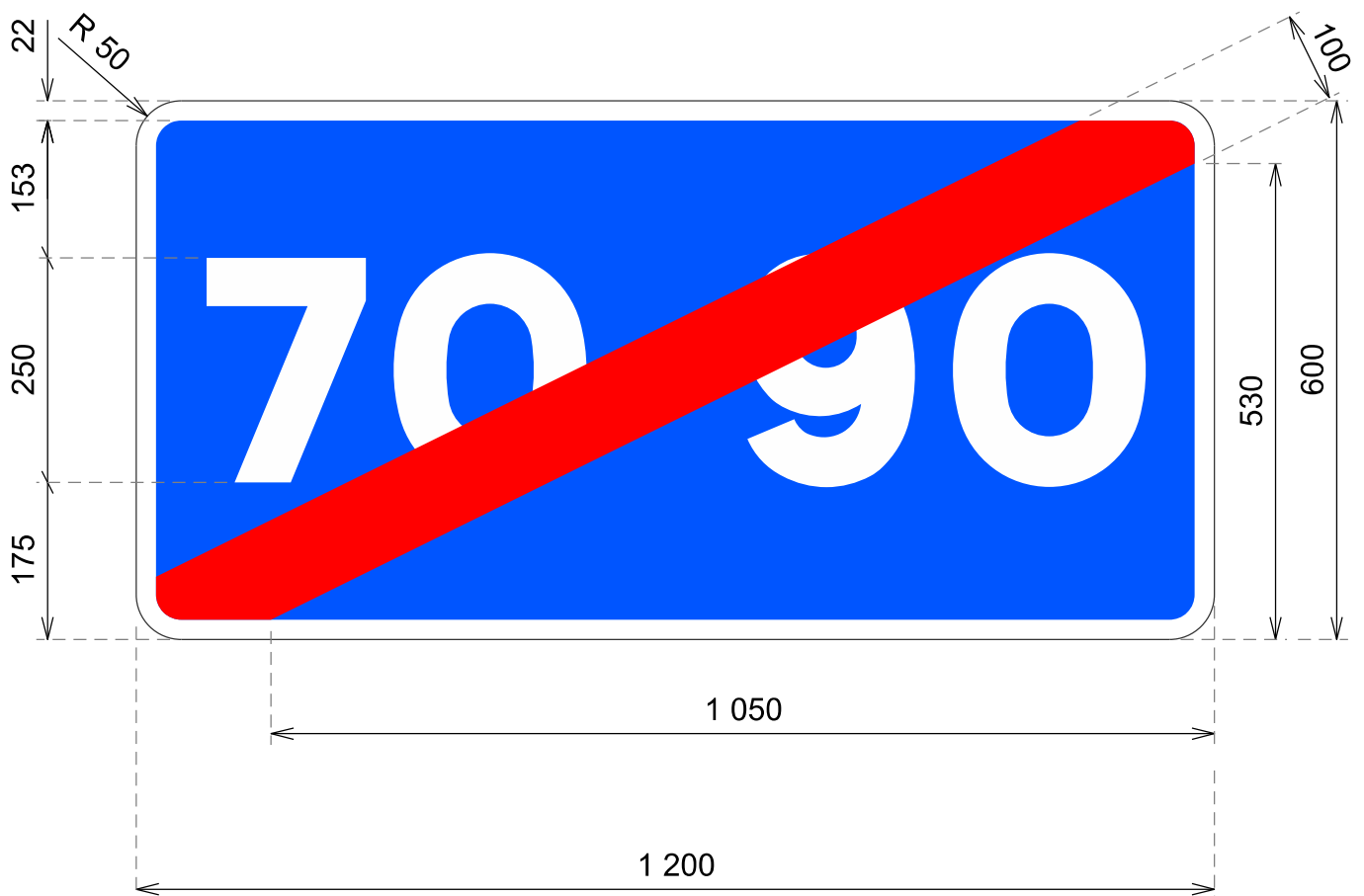

cotas en mm

tamaño para autopista y autovía: 1600 x 800

tamaño para carretera convencional sin arcén: 800 x 400

Fin de intervalo aconsejado de velocidades

**S-10**

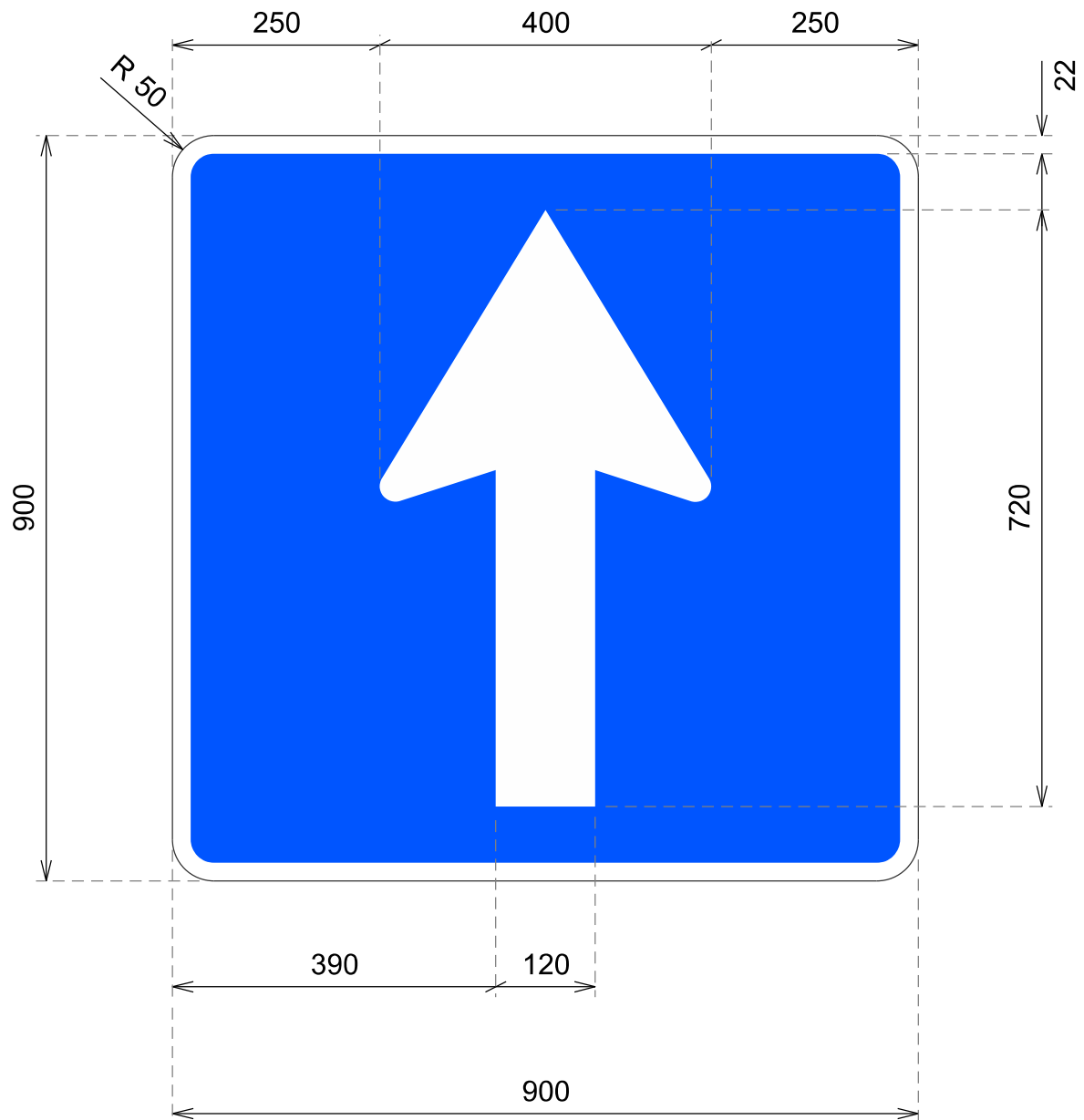

cotas en mm

Calzada de un carril de sentido único

S-11

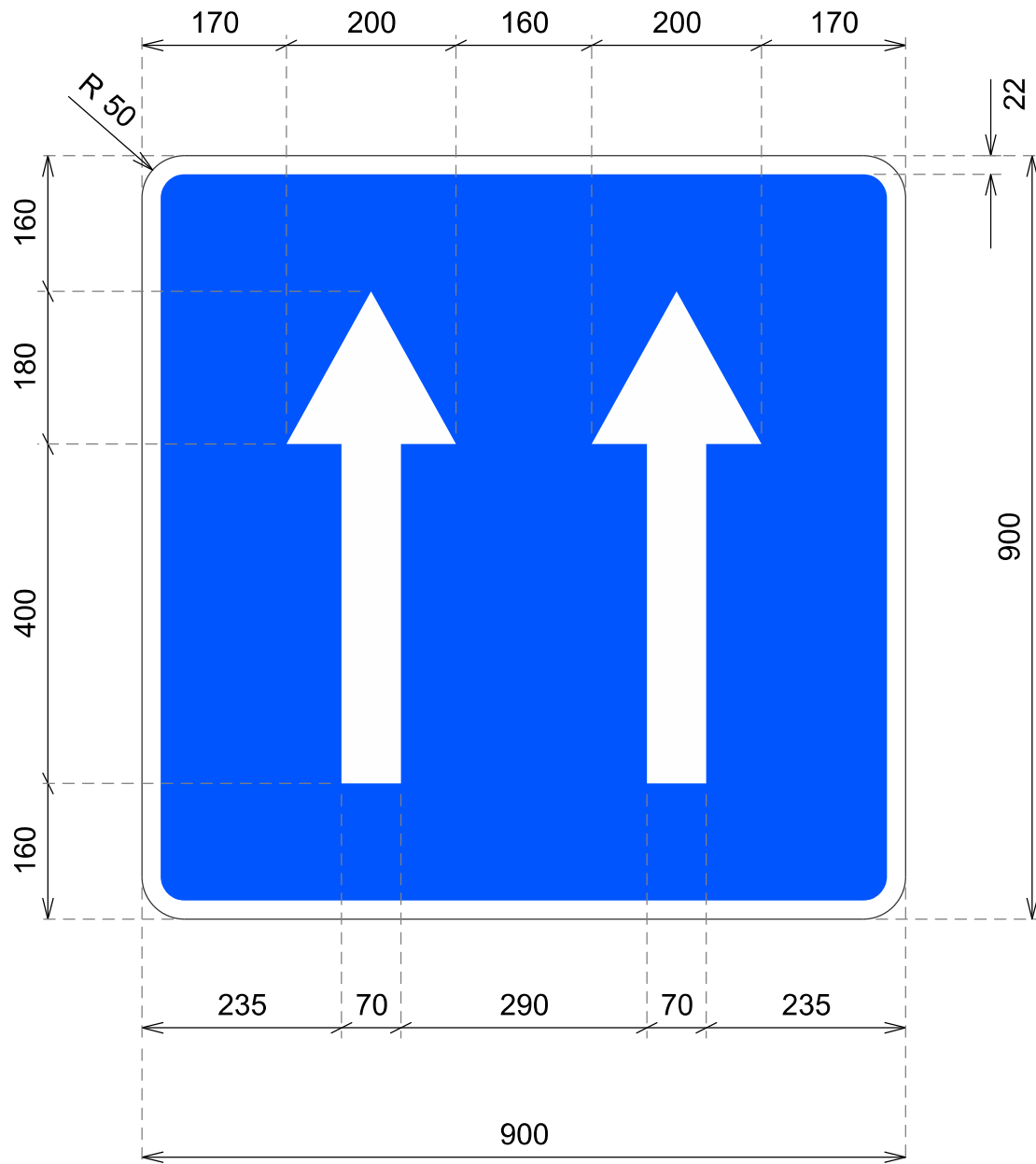

cotas en mm

Calzada de dos carriles de sentido único

S-11a

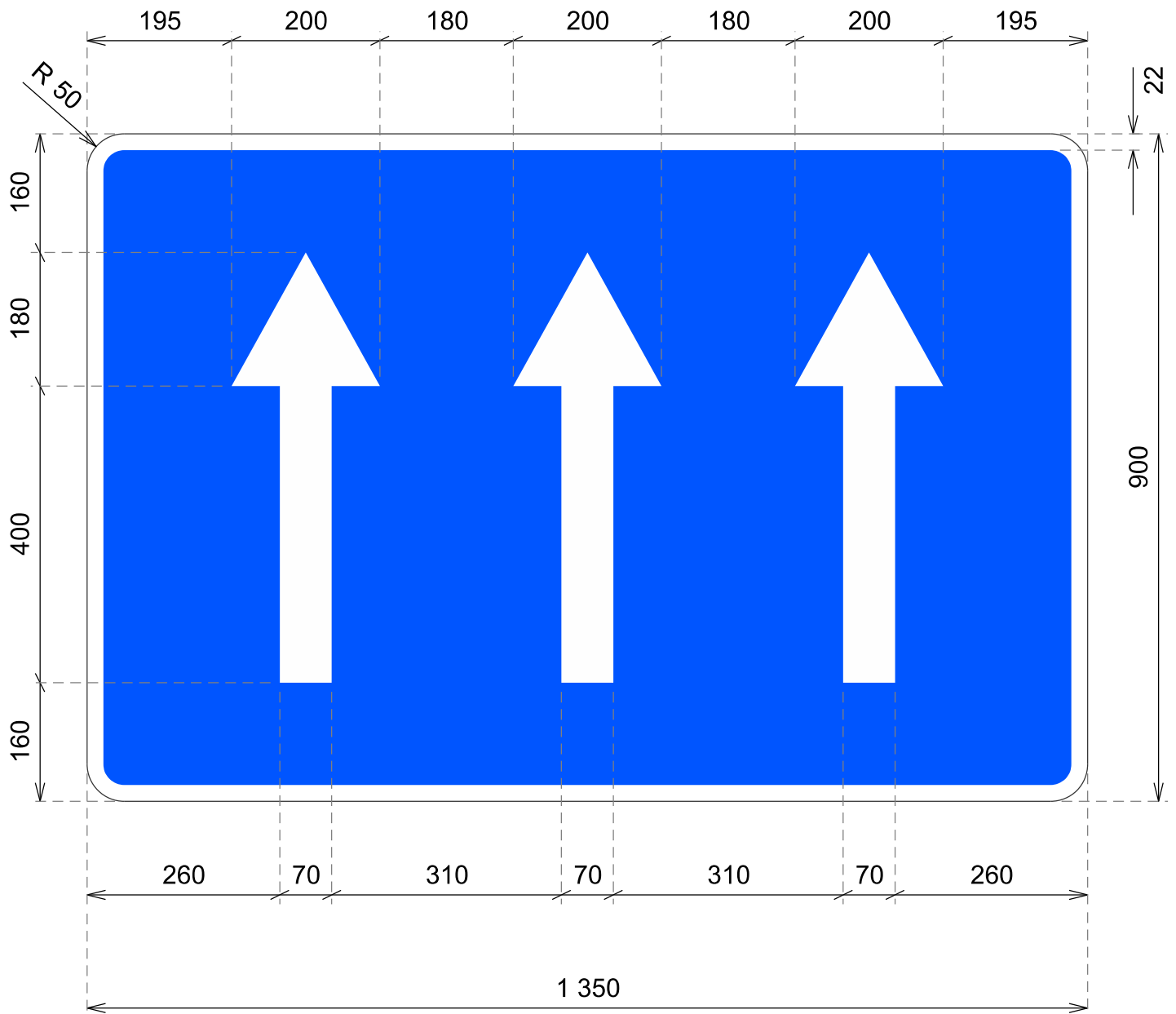

cotas en mm

Calzada de tres carriles de sentido único

**S-11b**

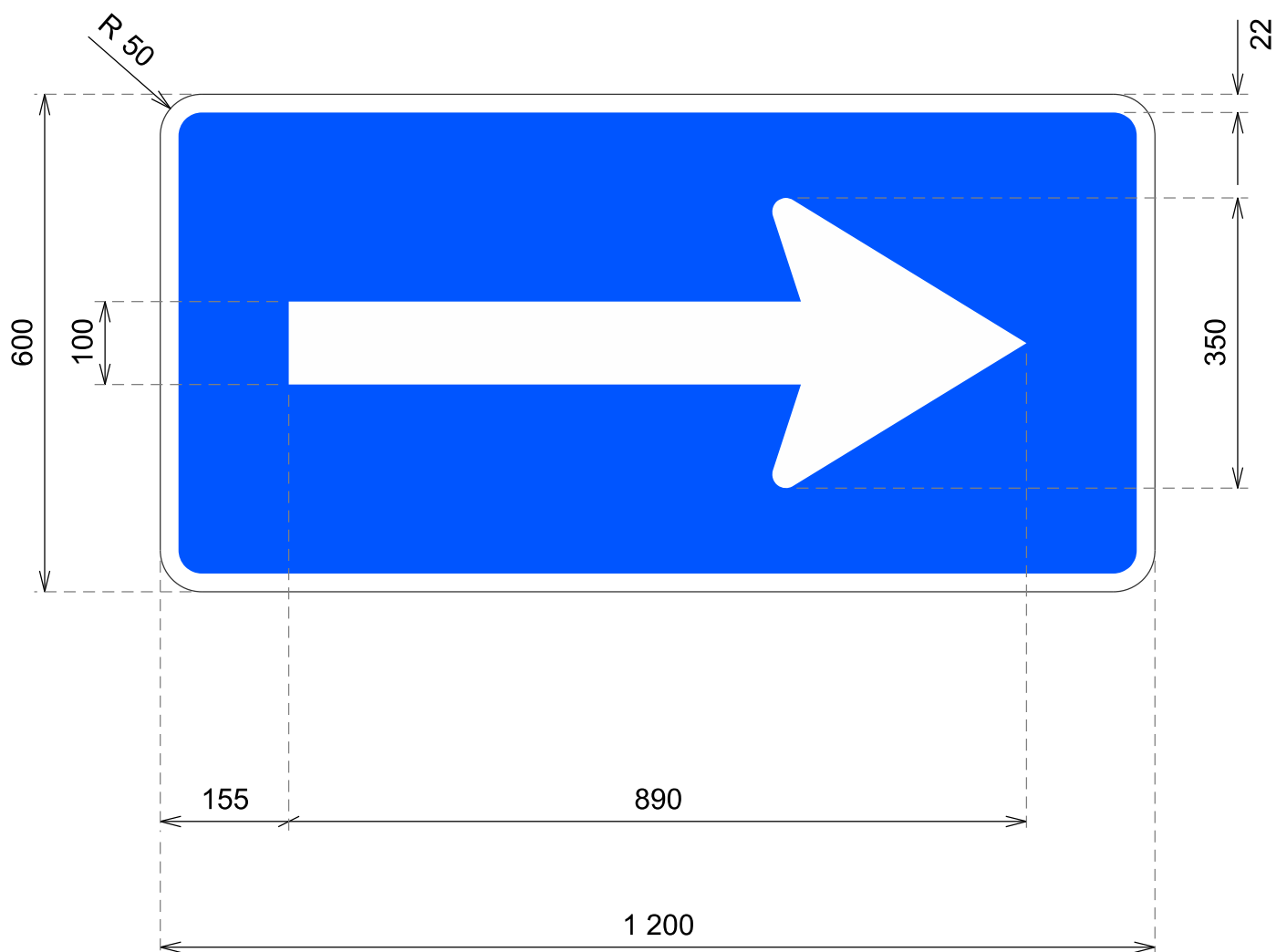

cotas en mm

tamaño para autopista y autovía: 1600 x 800

tamaño para carretera convencional sin arcén: 800 x 400

Tramo de calzada de sentido único

**S-12**

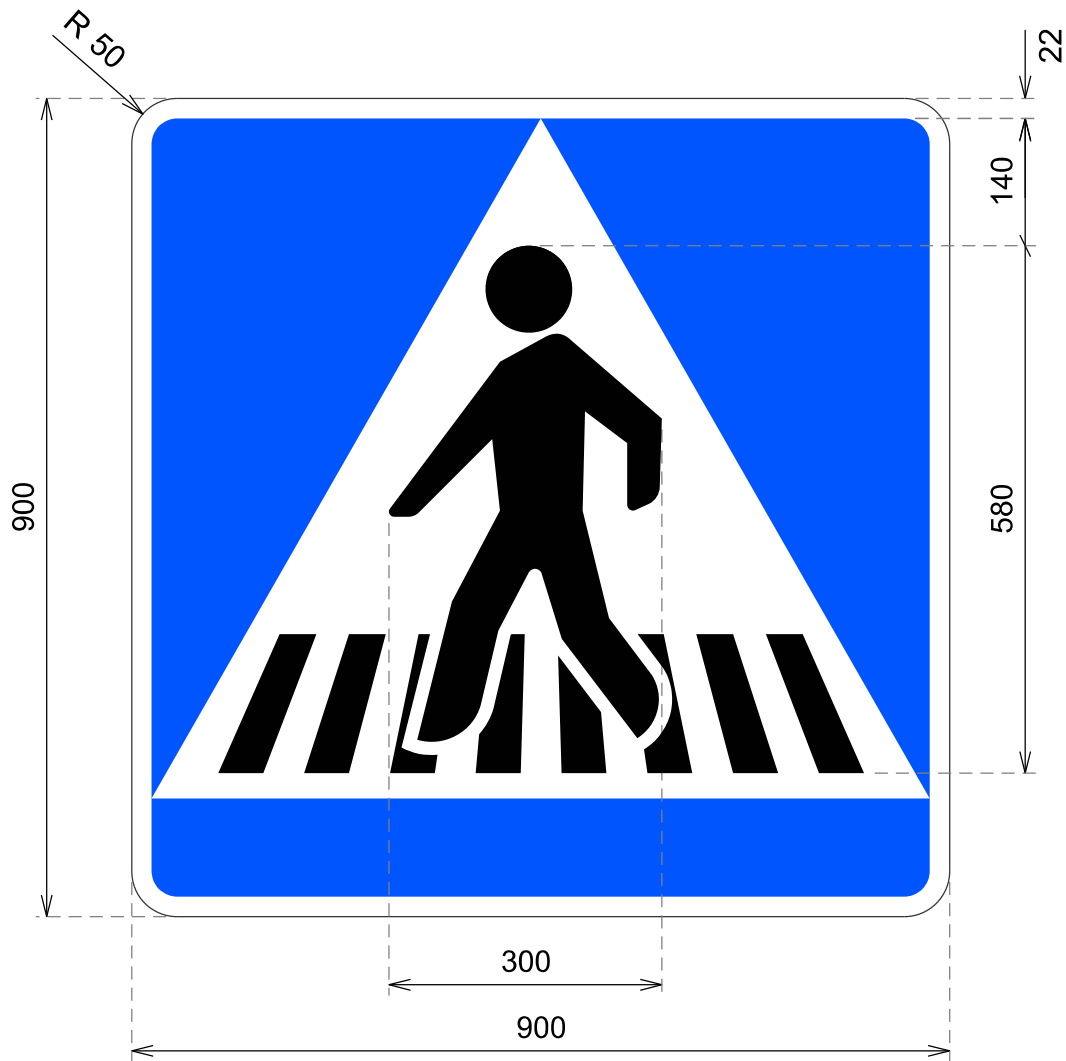

cotas en mm

Situación de un paso para peatones

S-13



cotas en mm

Paso superior para peatones

S-14a





cotas en mm

Paso inferior para peatones

S-14b



cotas en mm

Paso superior para peatones con rampa

S-14c



cotas en mm

Paso inferior para peatones con rampa

**S-14d**



cotas en mm

Paso superior para peatones con rail para ciclos

**S-14e**



cotas en mm

Paso inferior para peatones con rail para ciclos

**S-14f**

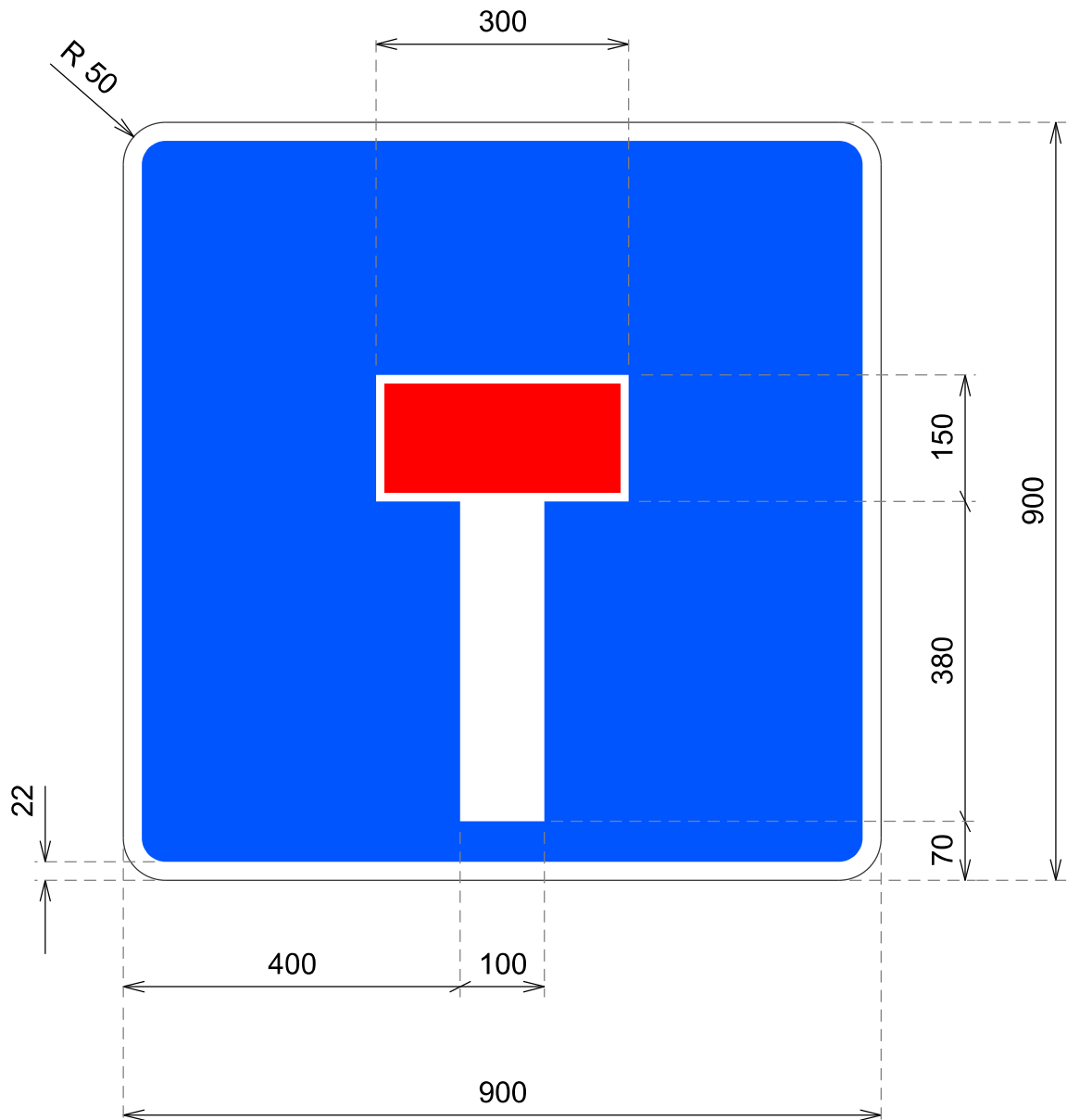

cotas en mm

Calzada sin salida

S-15a

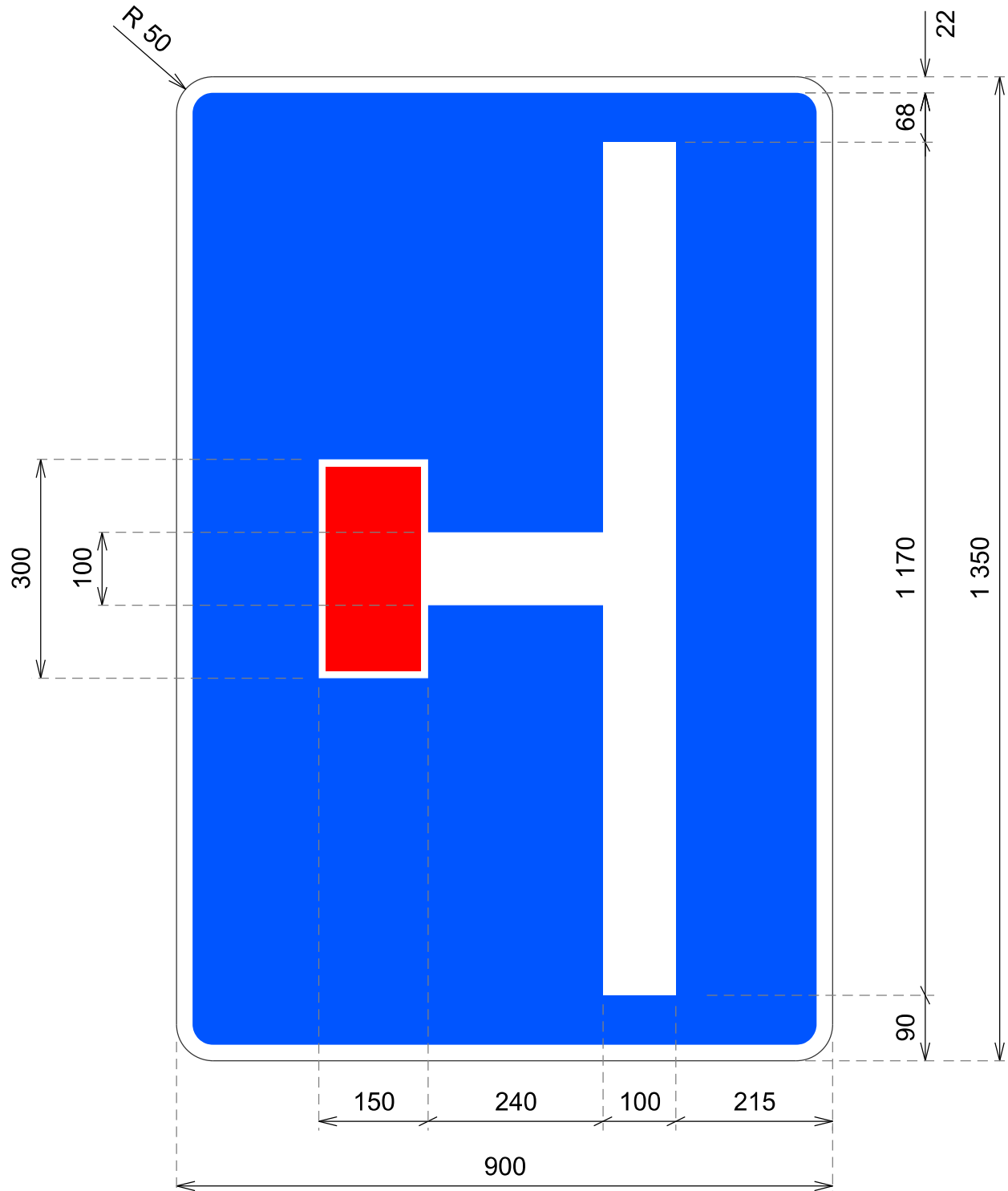

cotas en mm

Preseñalización de calzada sin salida

**S-15b**

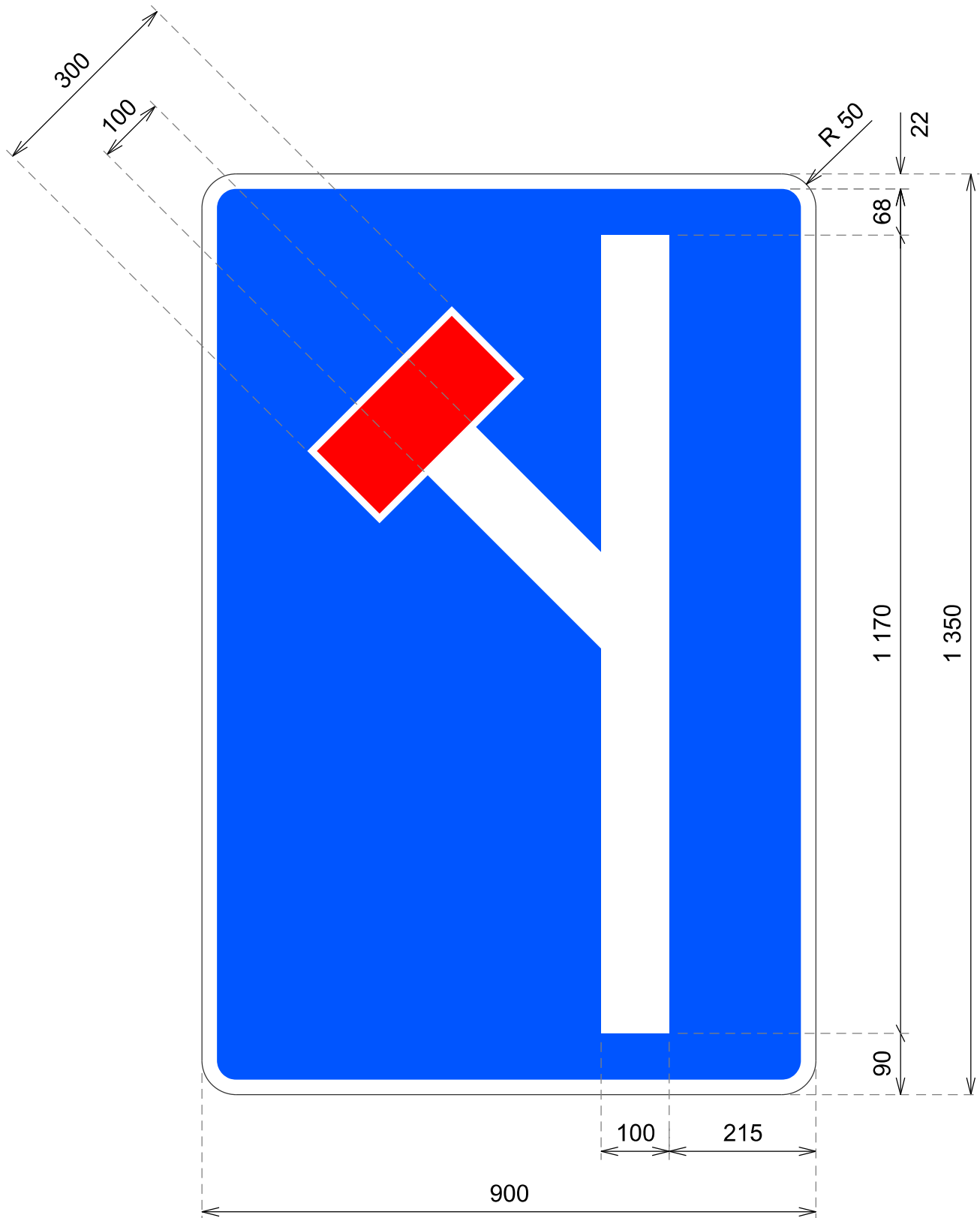

cotas en mm

Preseñalización de calzada sin salida

S-15c



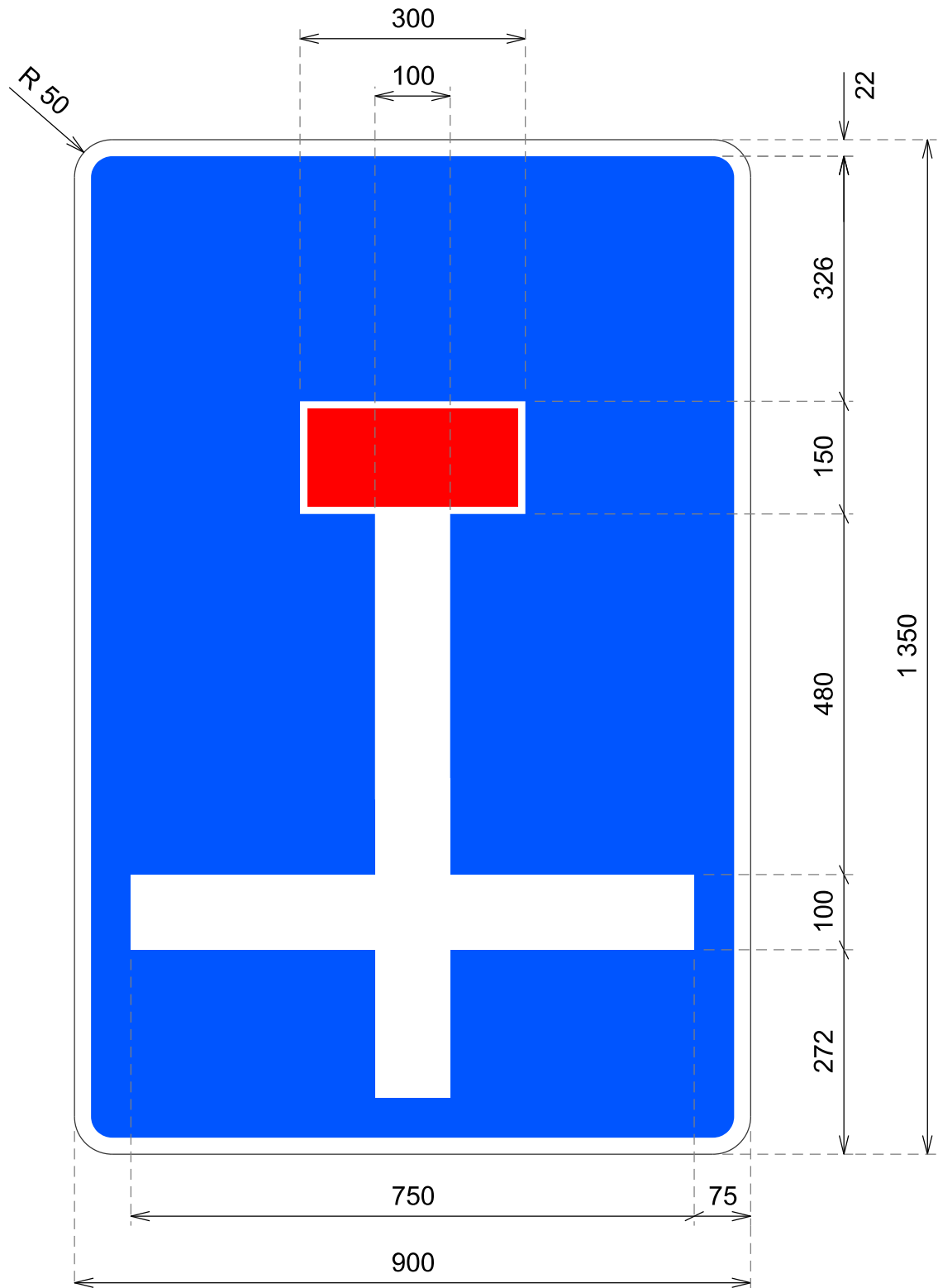

cotas en mm

Preseñalización de calzada sin salida

**S-15d**



cotas en mm

Calzada sin salida excepto para peatones o ciclos

**S-15e**

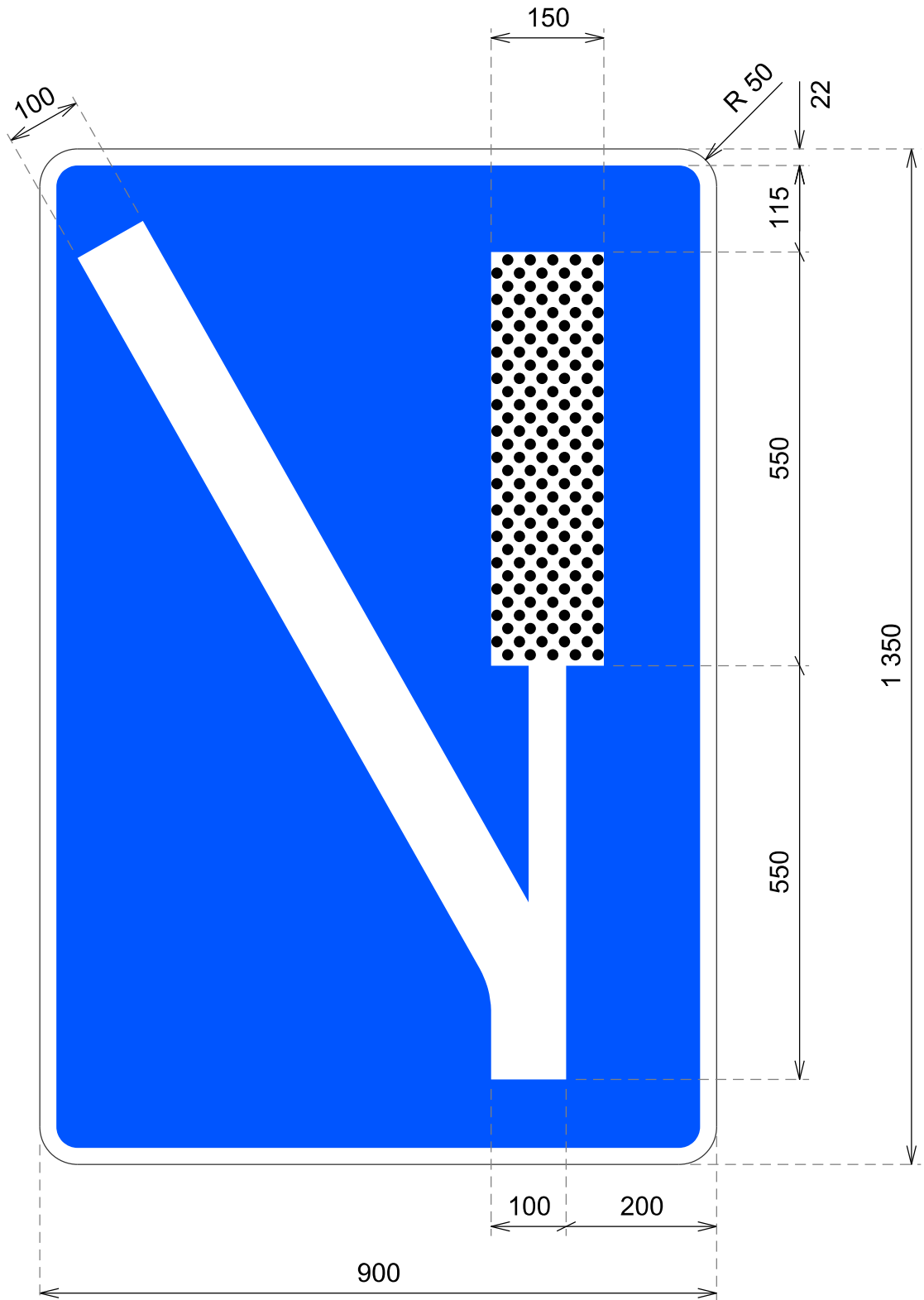

cotas en mm

Zona de frenado de emergencia

**S-16**

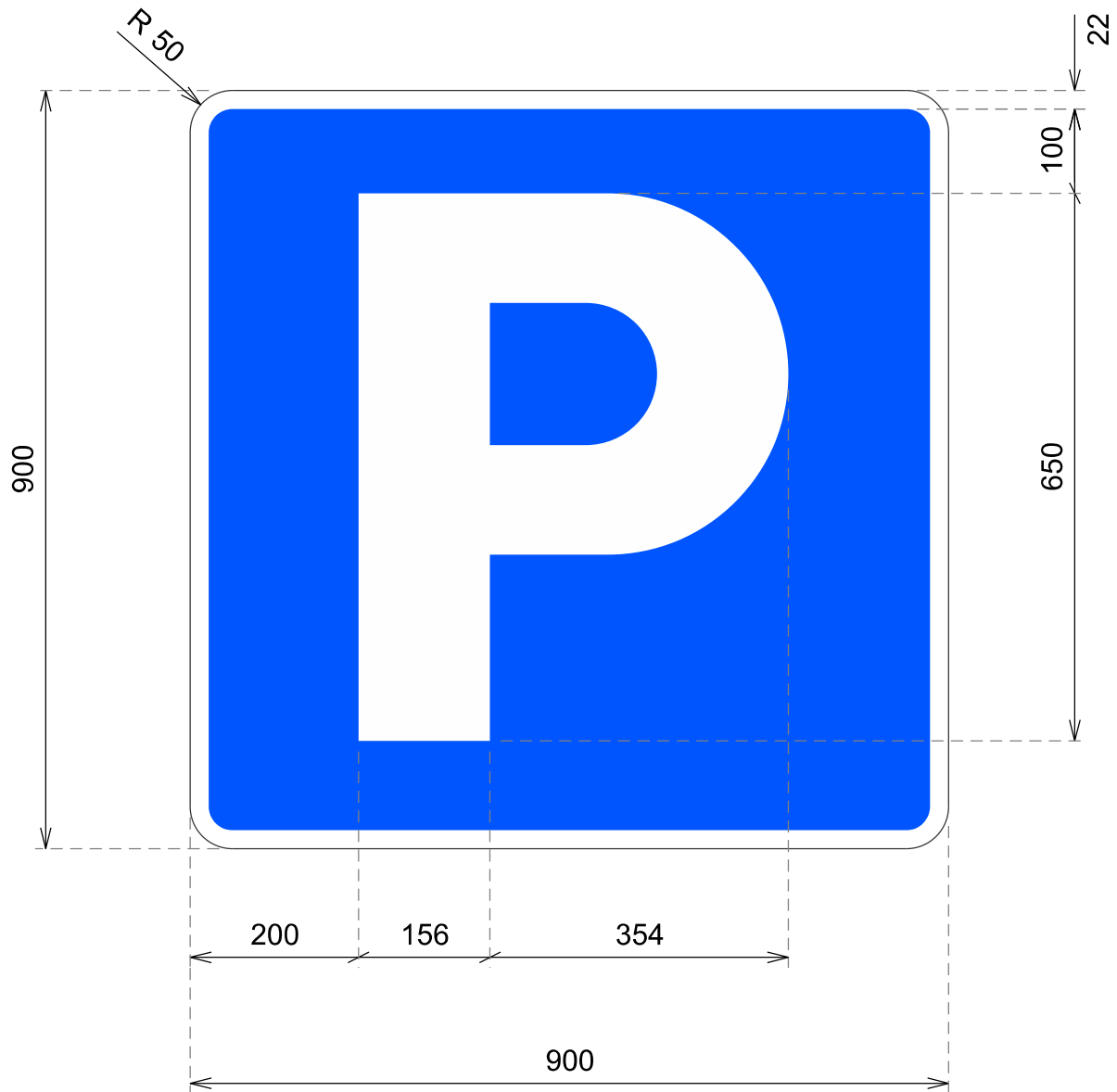

cotas en mm

Estacionamiento

S-17



cotas en mm

Estacionamiento de necesidad

S-17a

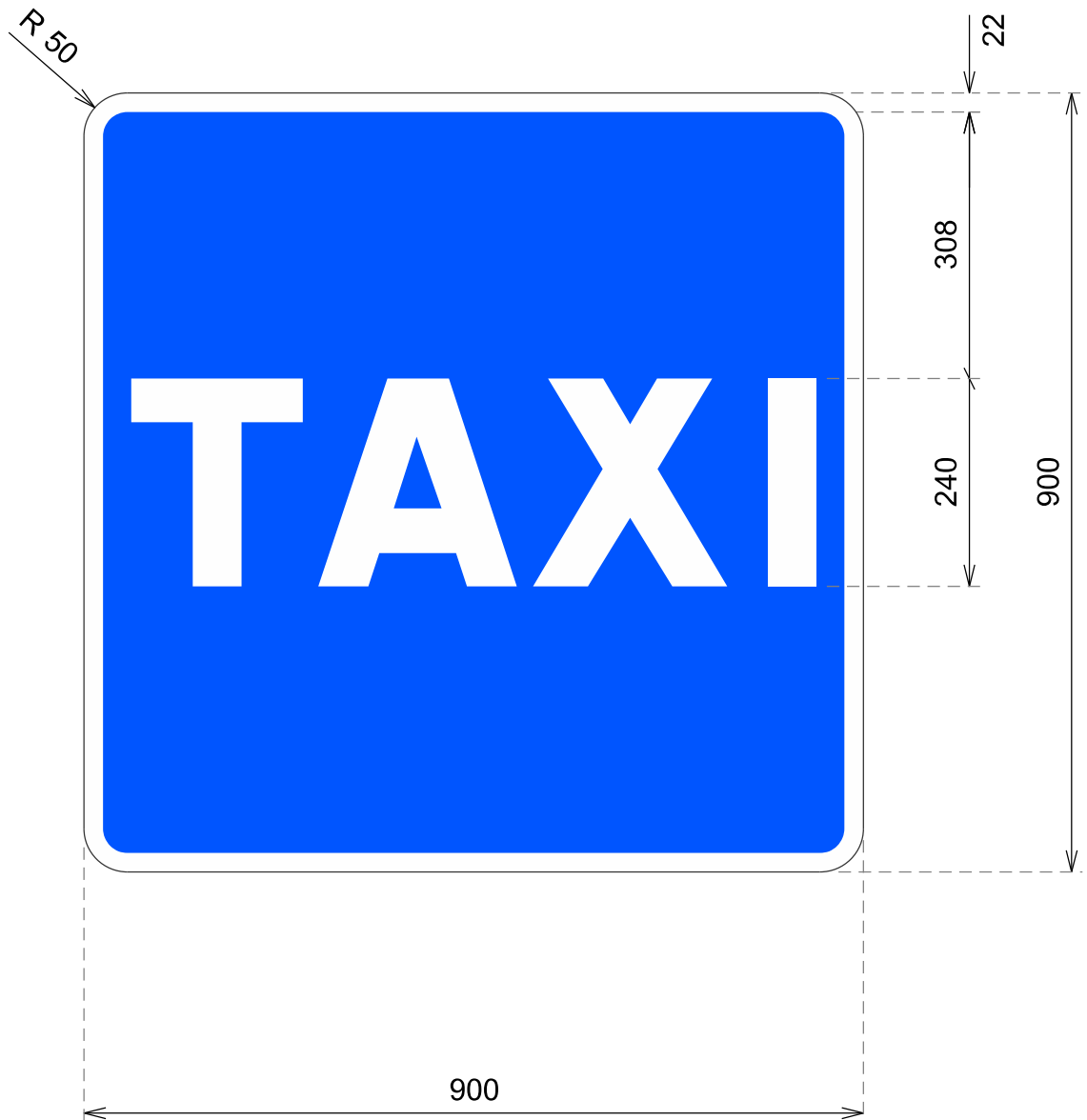

cotas en mm

Lugar reservado para taxis

**S-18**

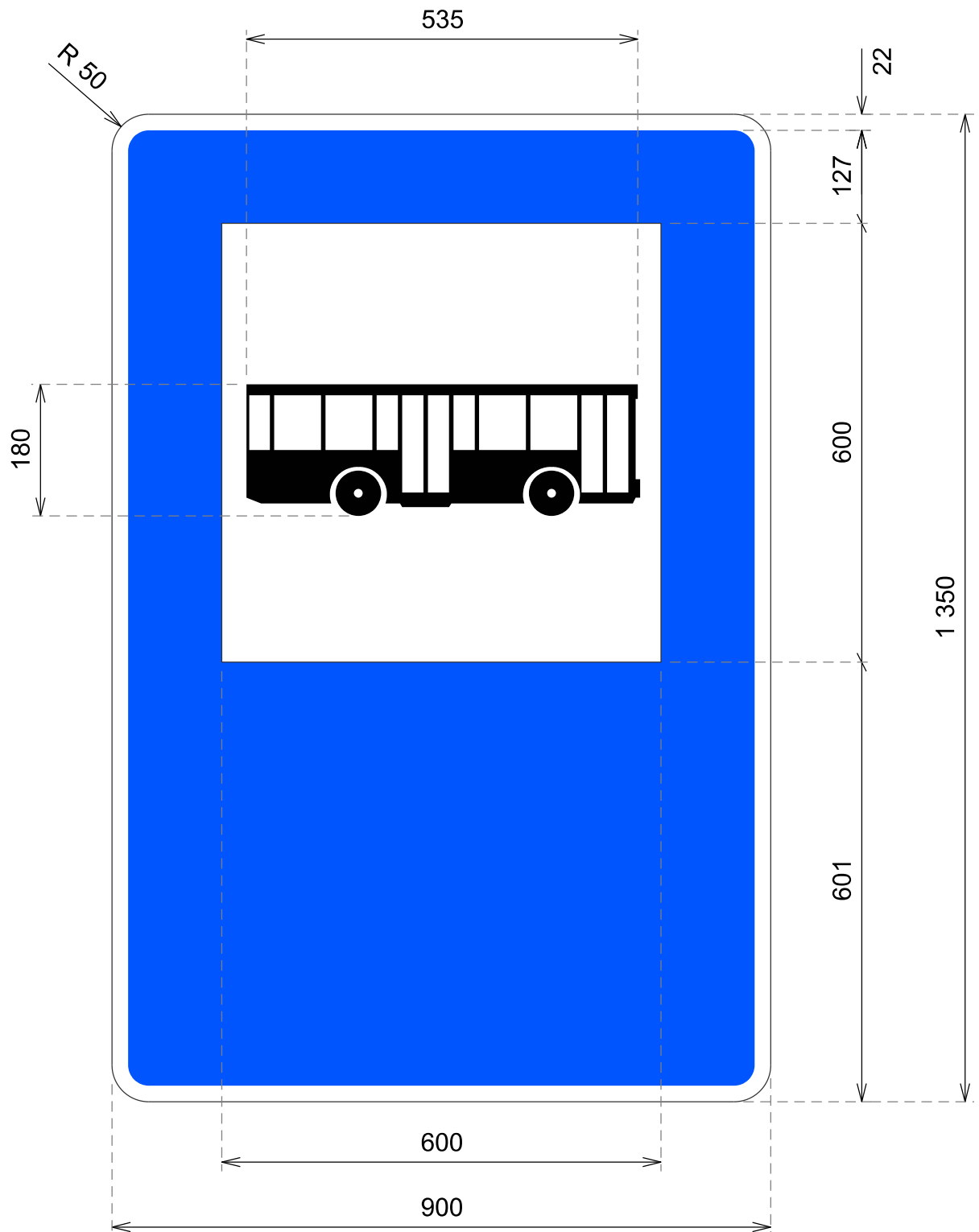

cotas en mm

Parada de autobuses

S-19

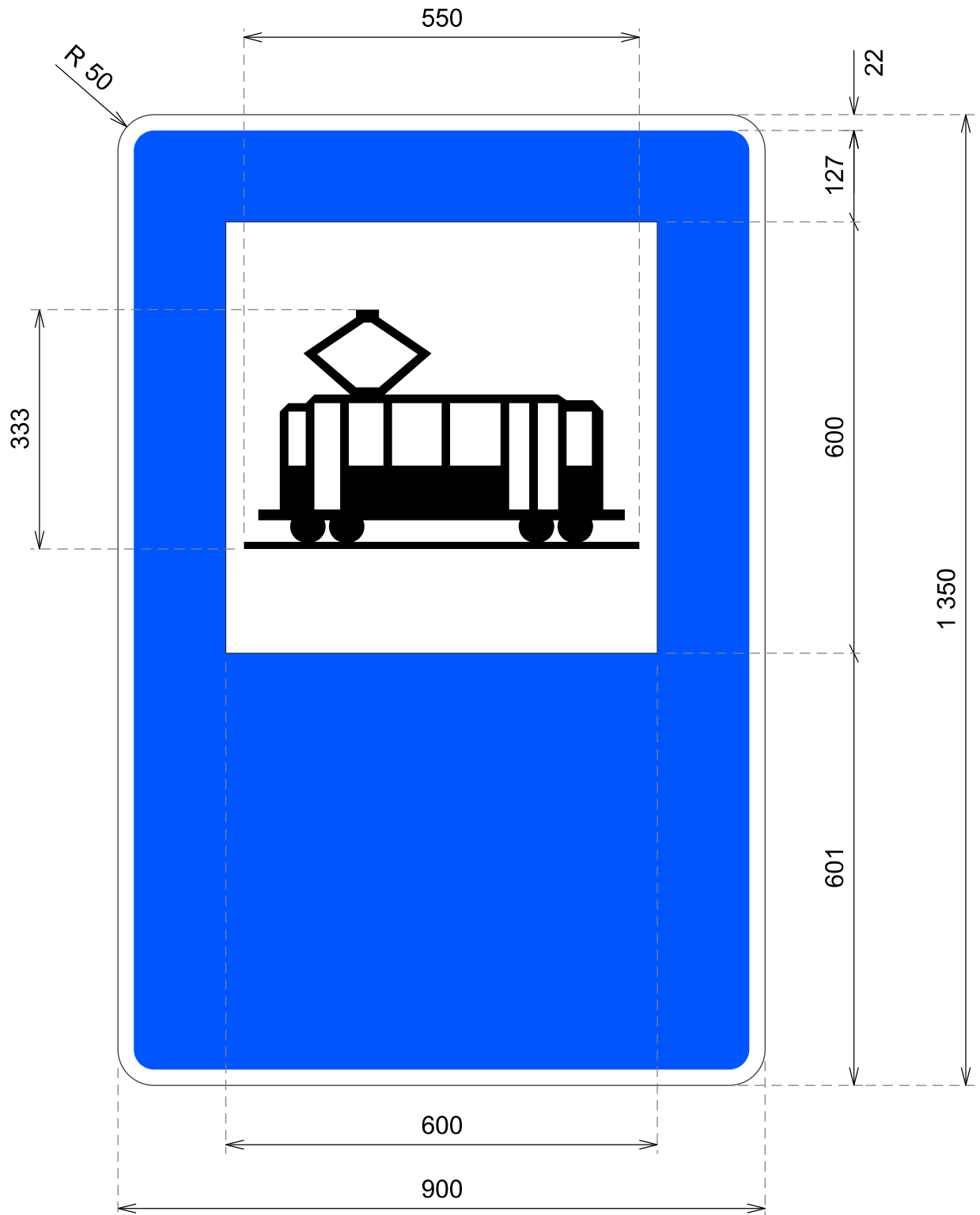

cotas en mm

Parada de tranvías

S-20





cotas en mm

tamaño para autopista y autovía  
para el resto de carreteras se podrá reducir hasta un 25%

Transitabilidad en tramo o puerto de montaña

**S-21**

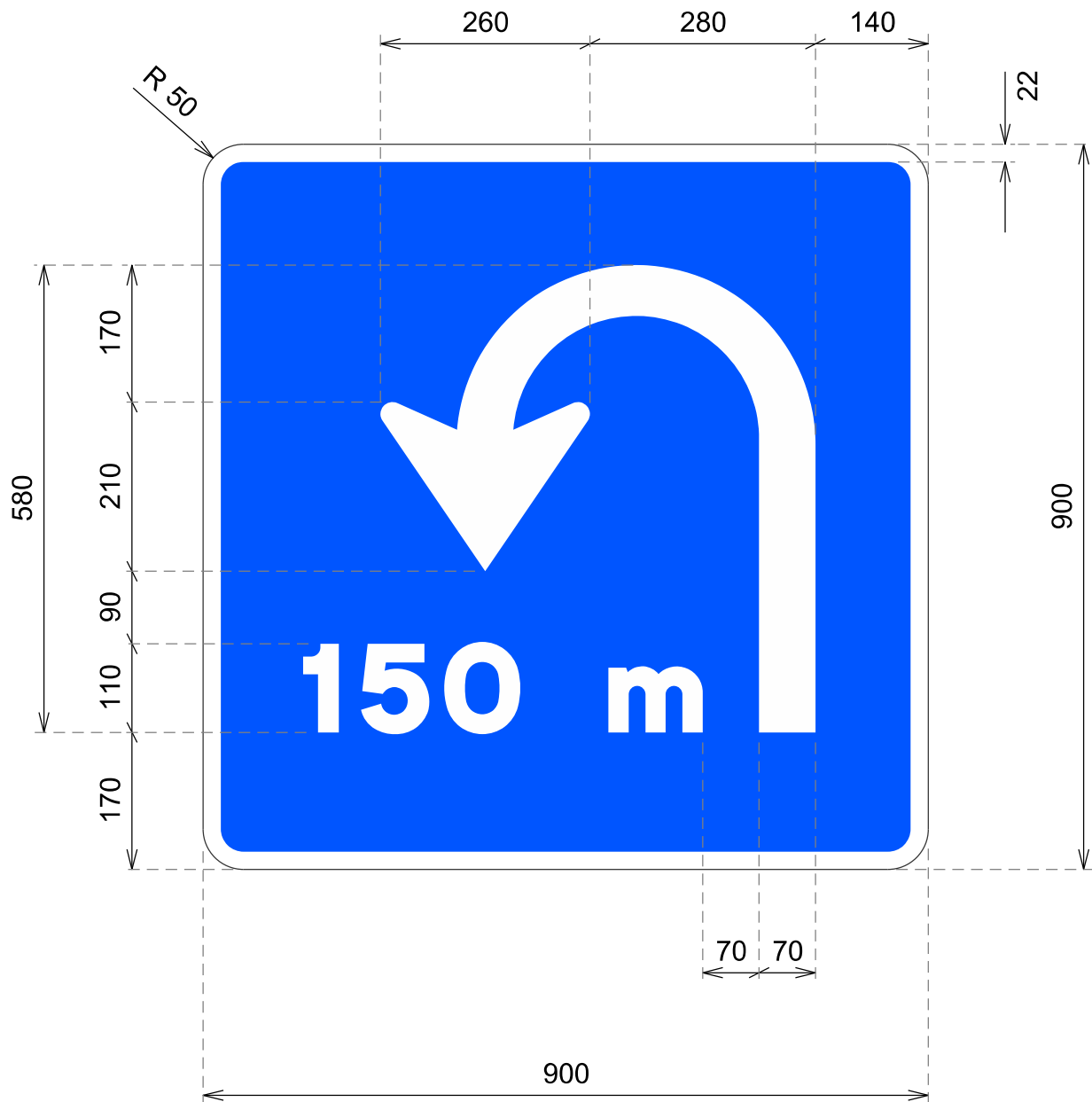

cotas en mm

Cambio de sentido al mismo nivel

S-22

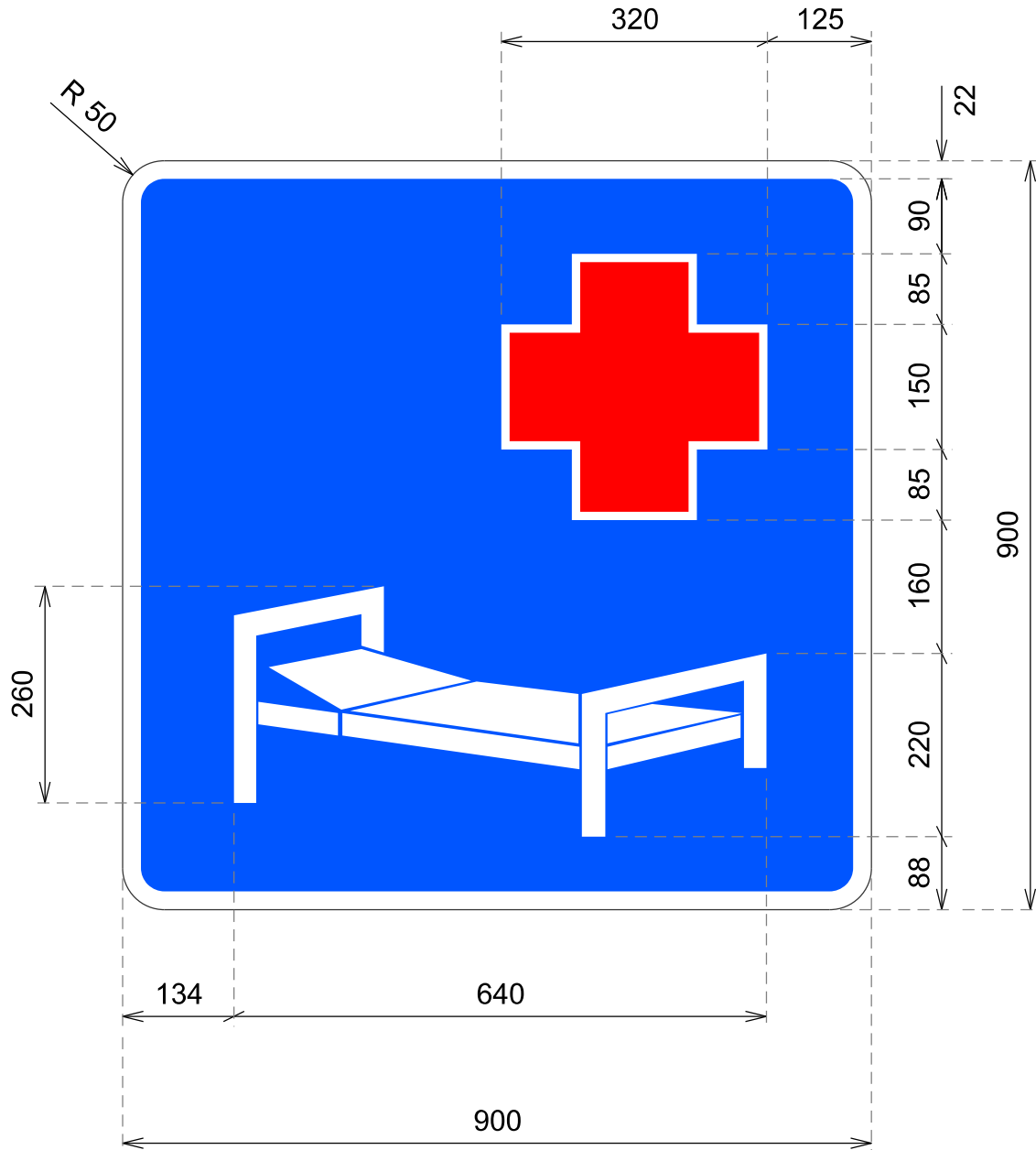

cotas en mm

Hospital

S-23

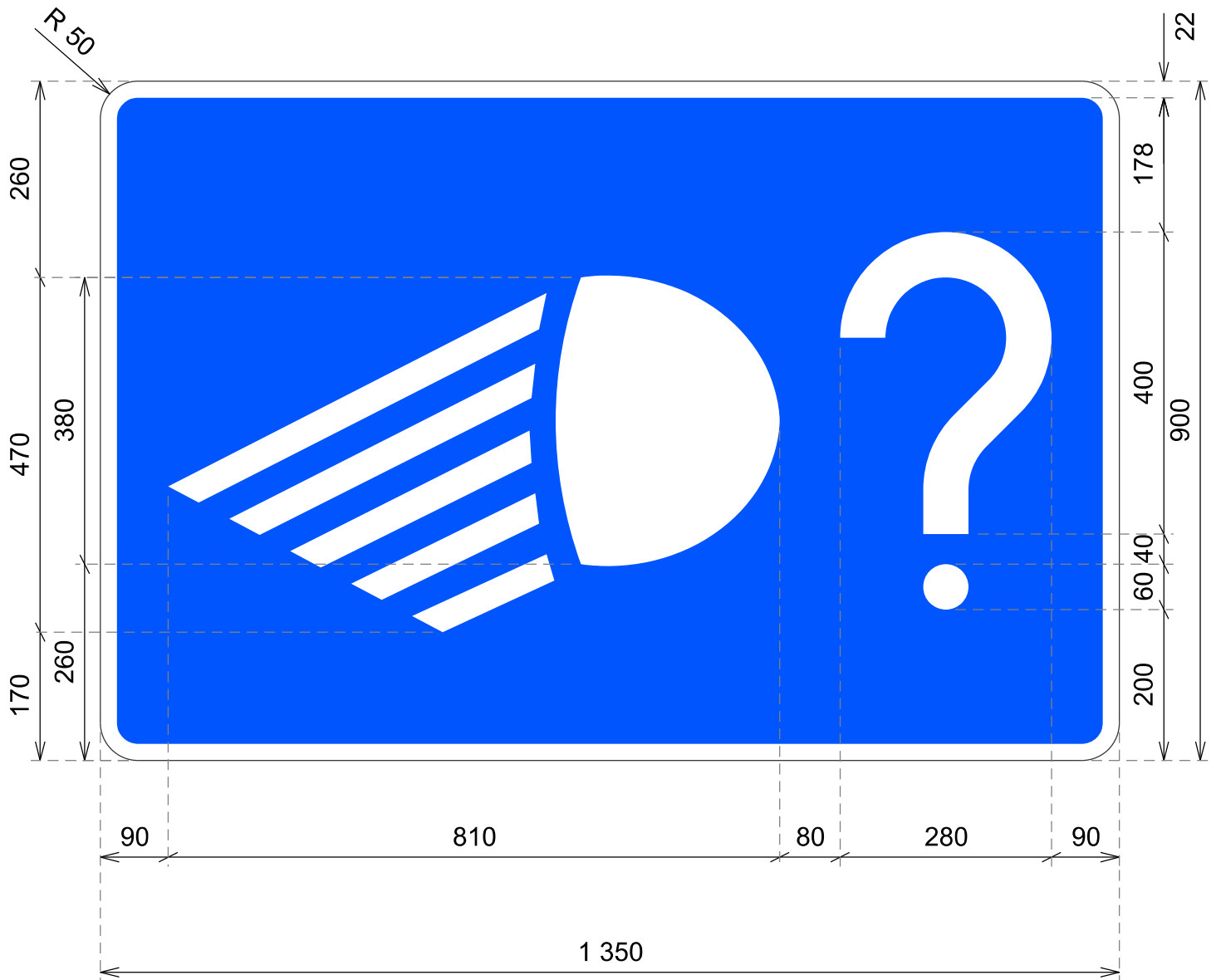

cotas en mm

Fin de obligación de alumbrado de corto alcance (cruce)

S-24

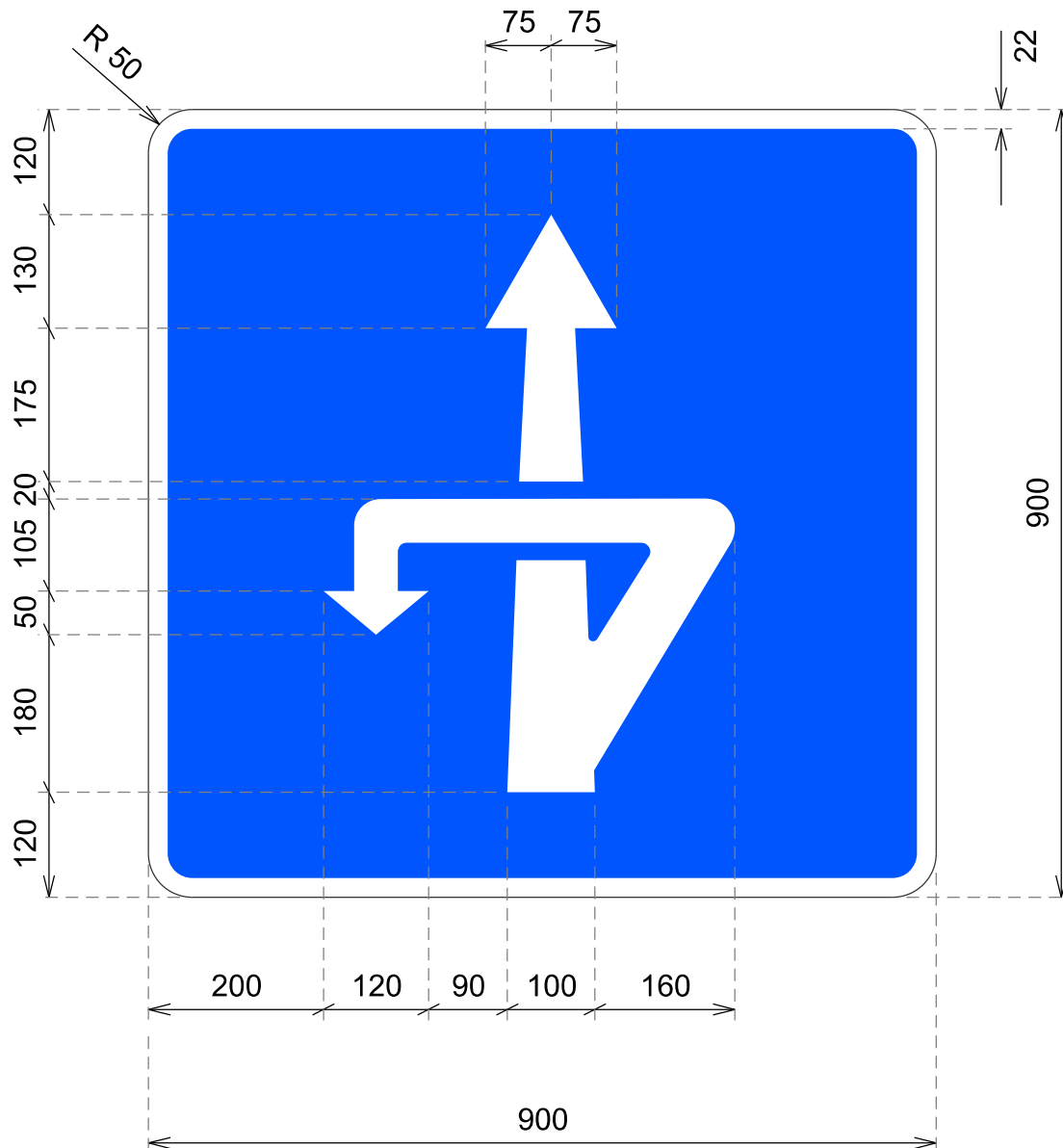

cotas en mm

Cambio de sentido a distinto nivel

S-25

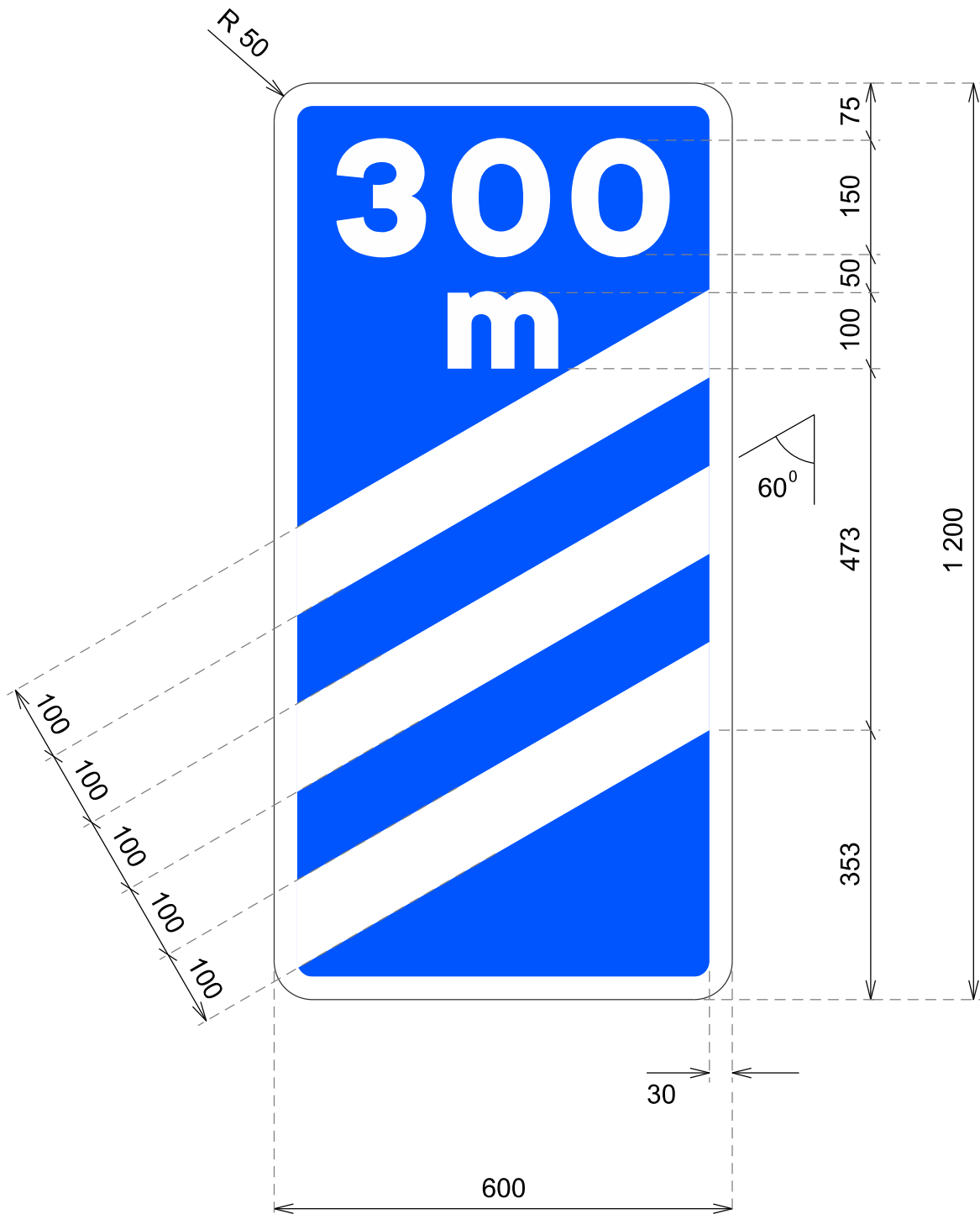

cotas en mm

tamaño único

Panel de aproximación a salida (300 m)

**S-26a**

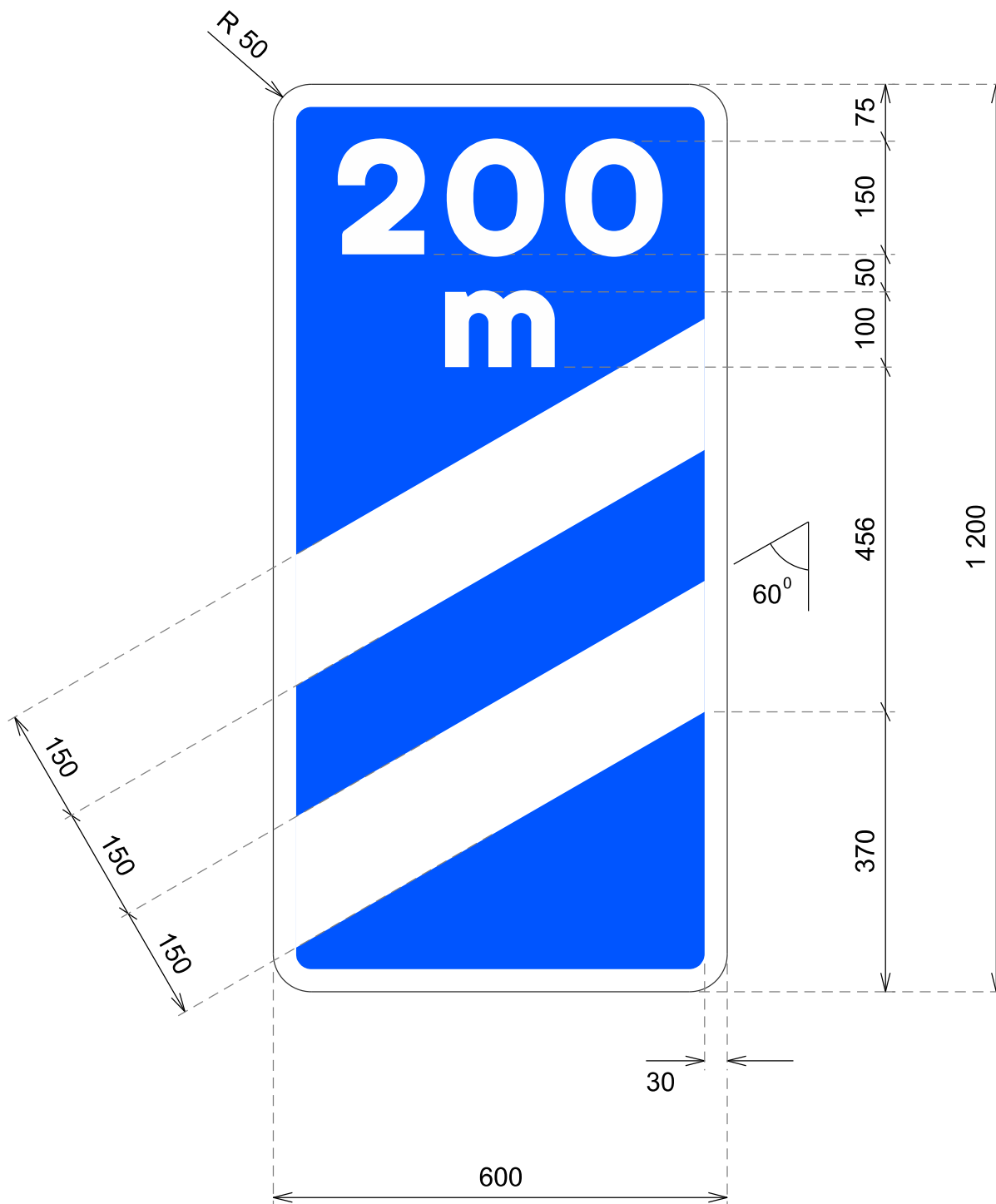

cotas en mm

tamaño único

Panel de aproximación a salida (200 m)

**S-26b**

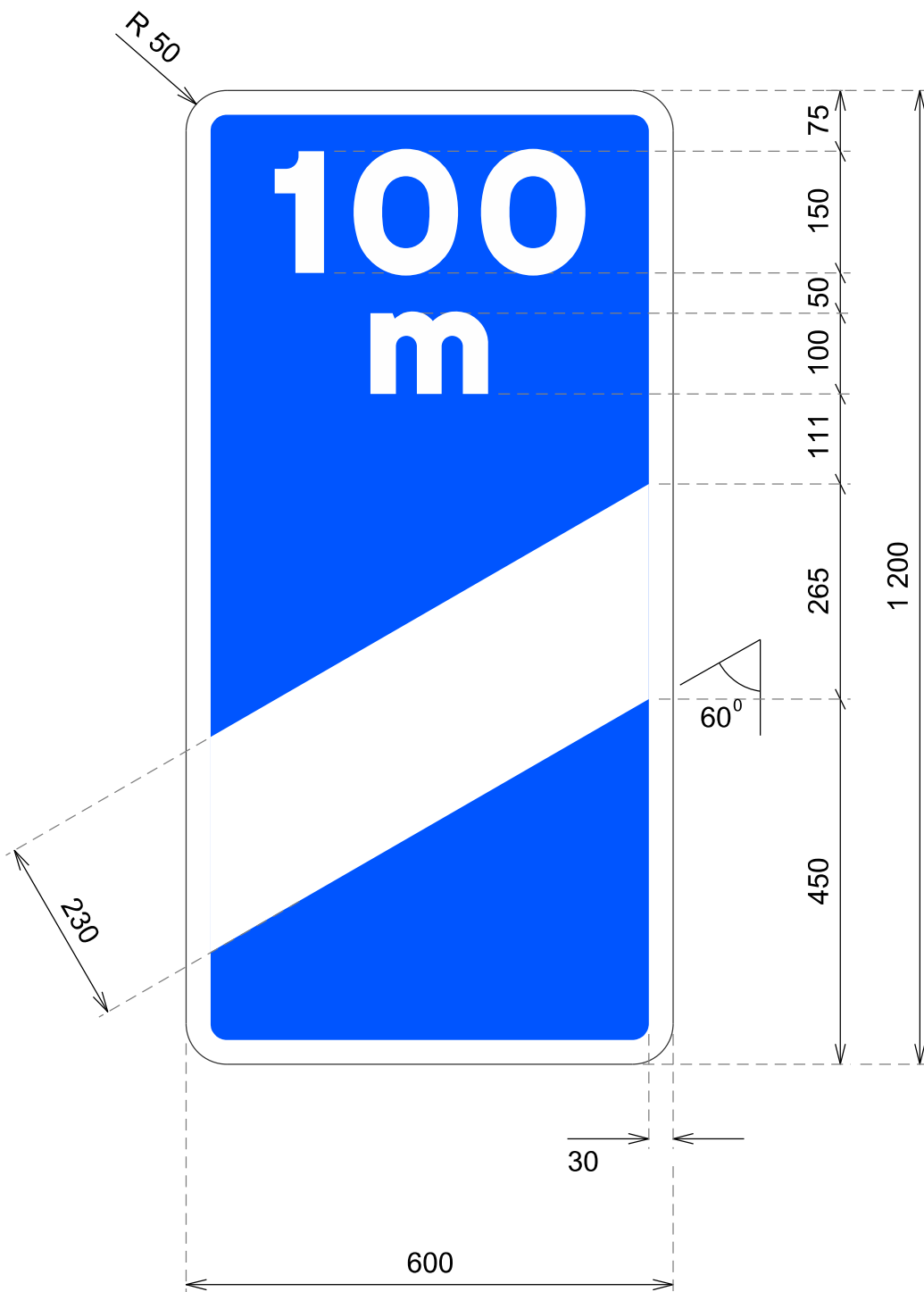

cotas en mm

tamaño único

Panel de aproximación a salida (100 m)

**S-26c**



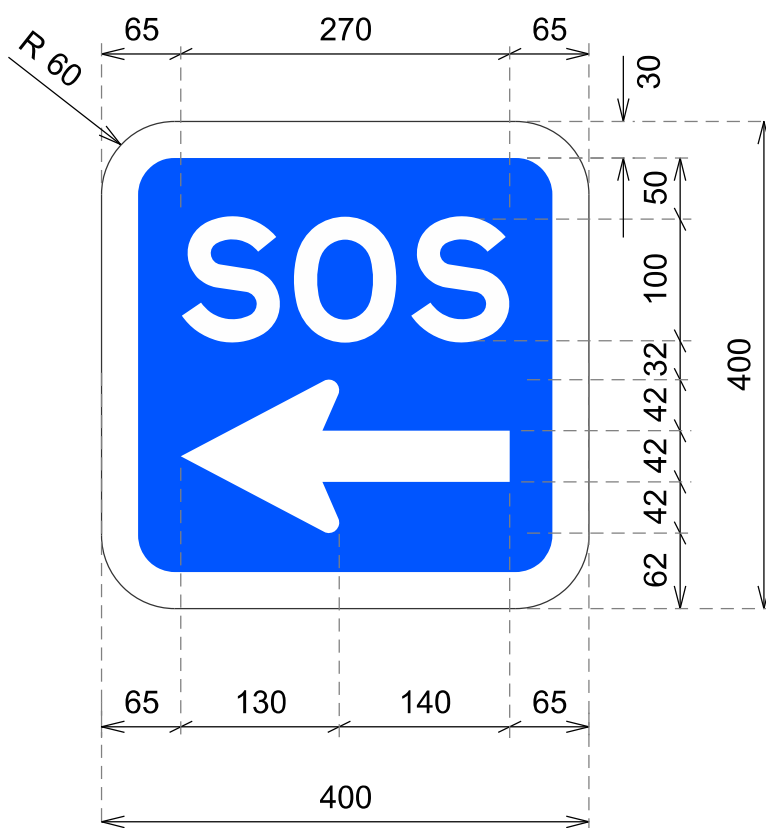

cotas en mm

tamaño único

Auxilio en carretera

S-27



cotas en mm

tamaño único

Zona residencial

**S-28**



cotas en mm

Fin de zona residencial

S-29

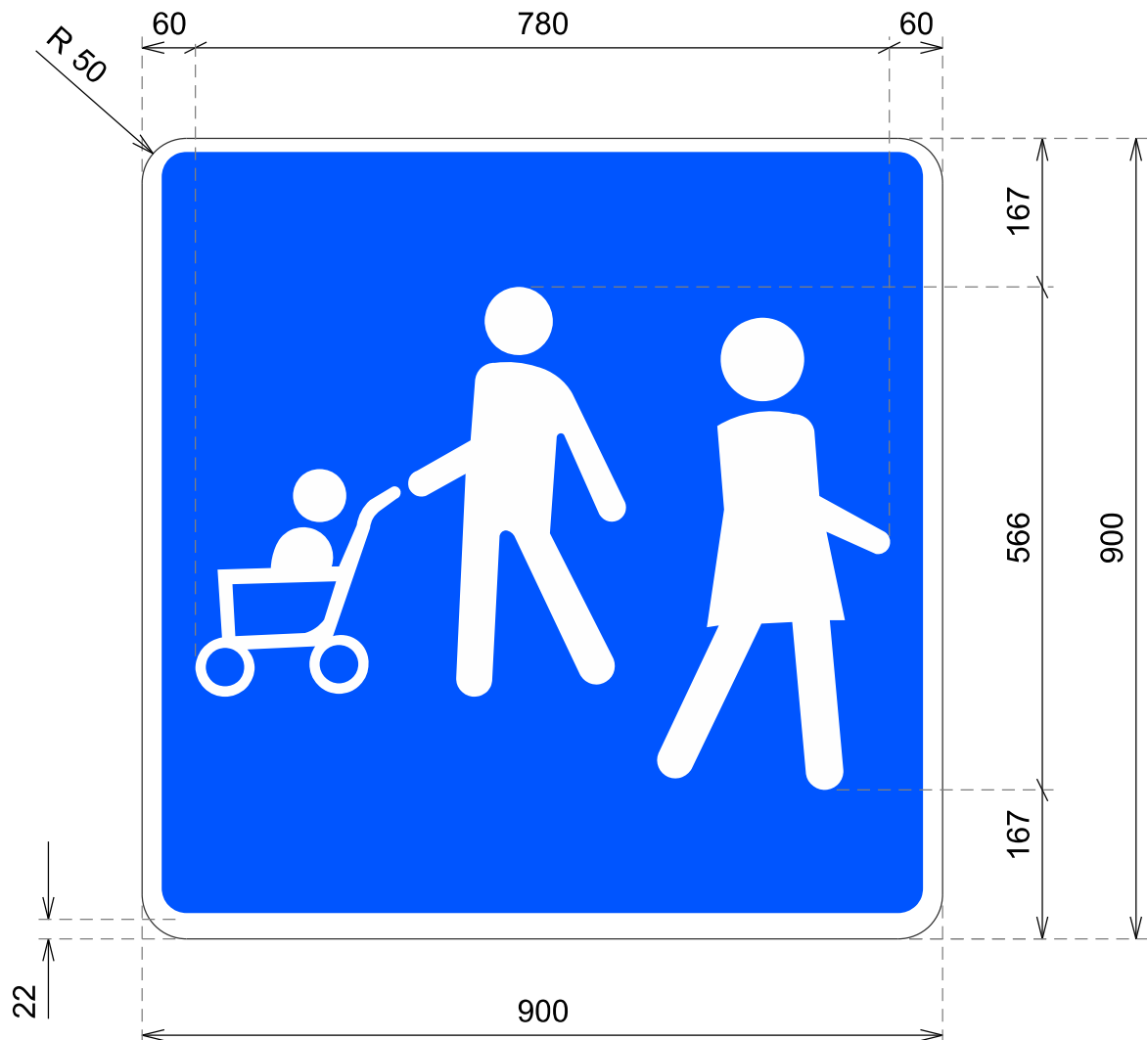

cotas en mm

Zona peatonal

S-30a

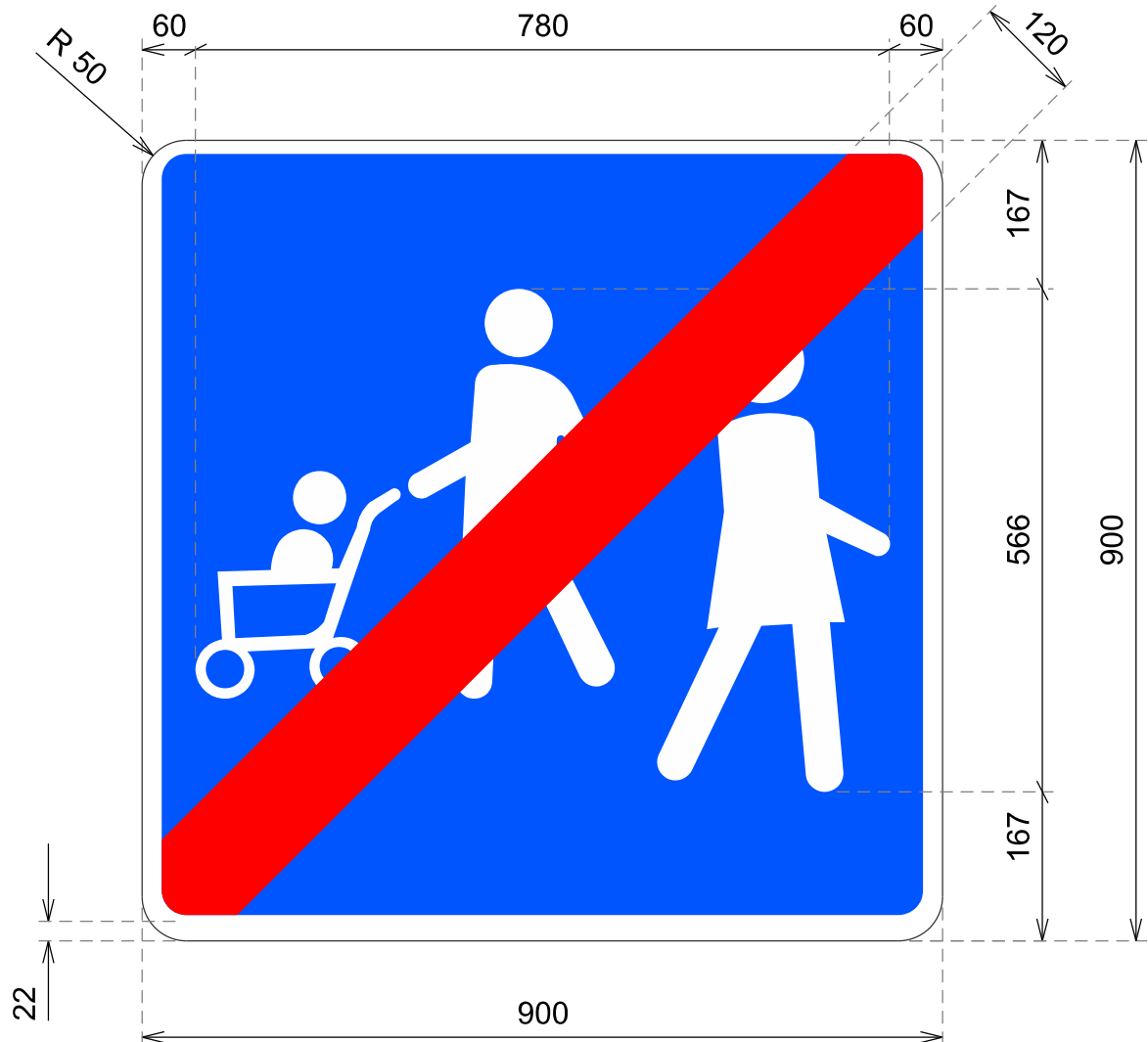

cotas en mm

Fin de zona peatonal

S-31a

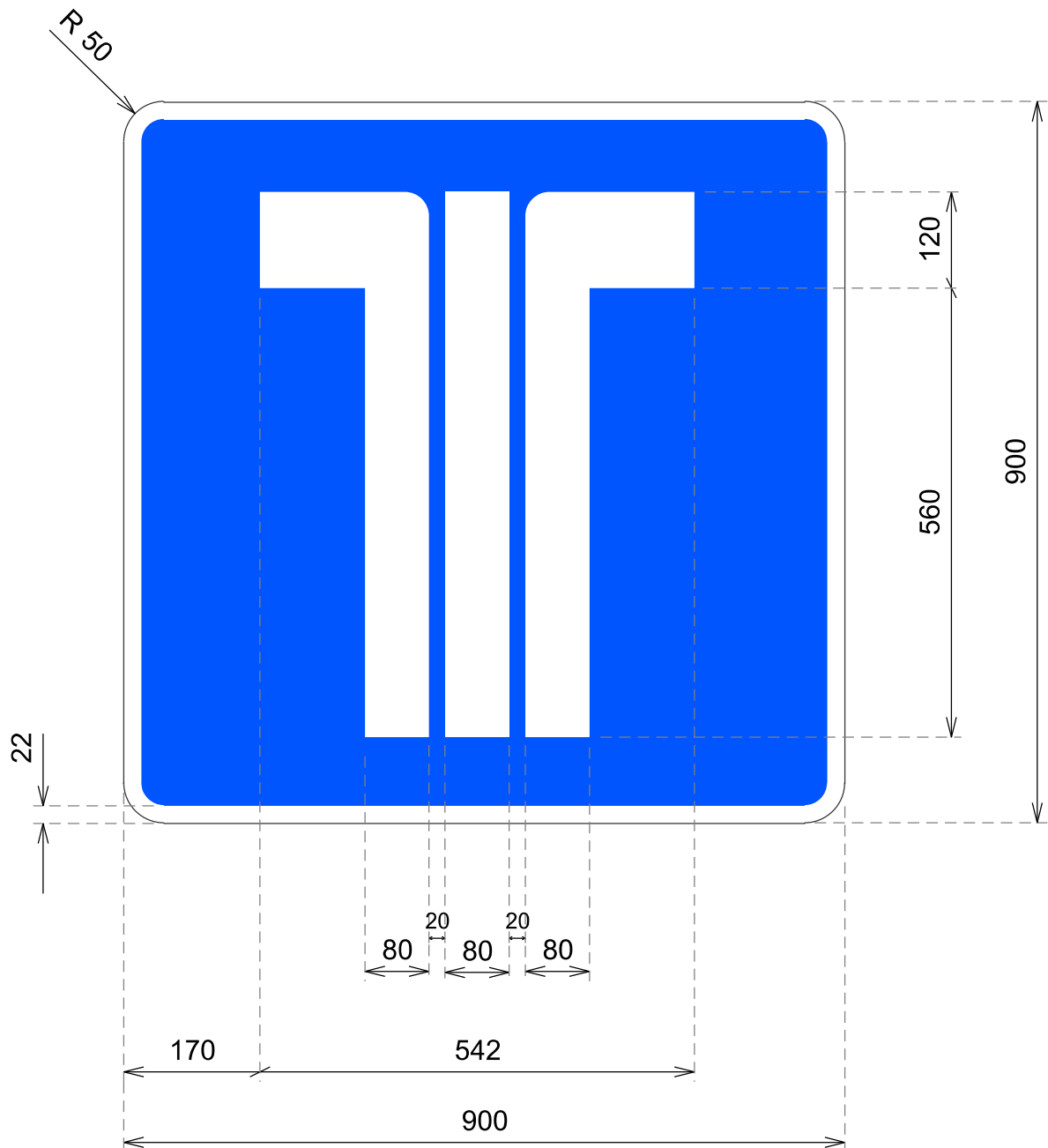

cotas en mm

Telepeaje

S-32

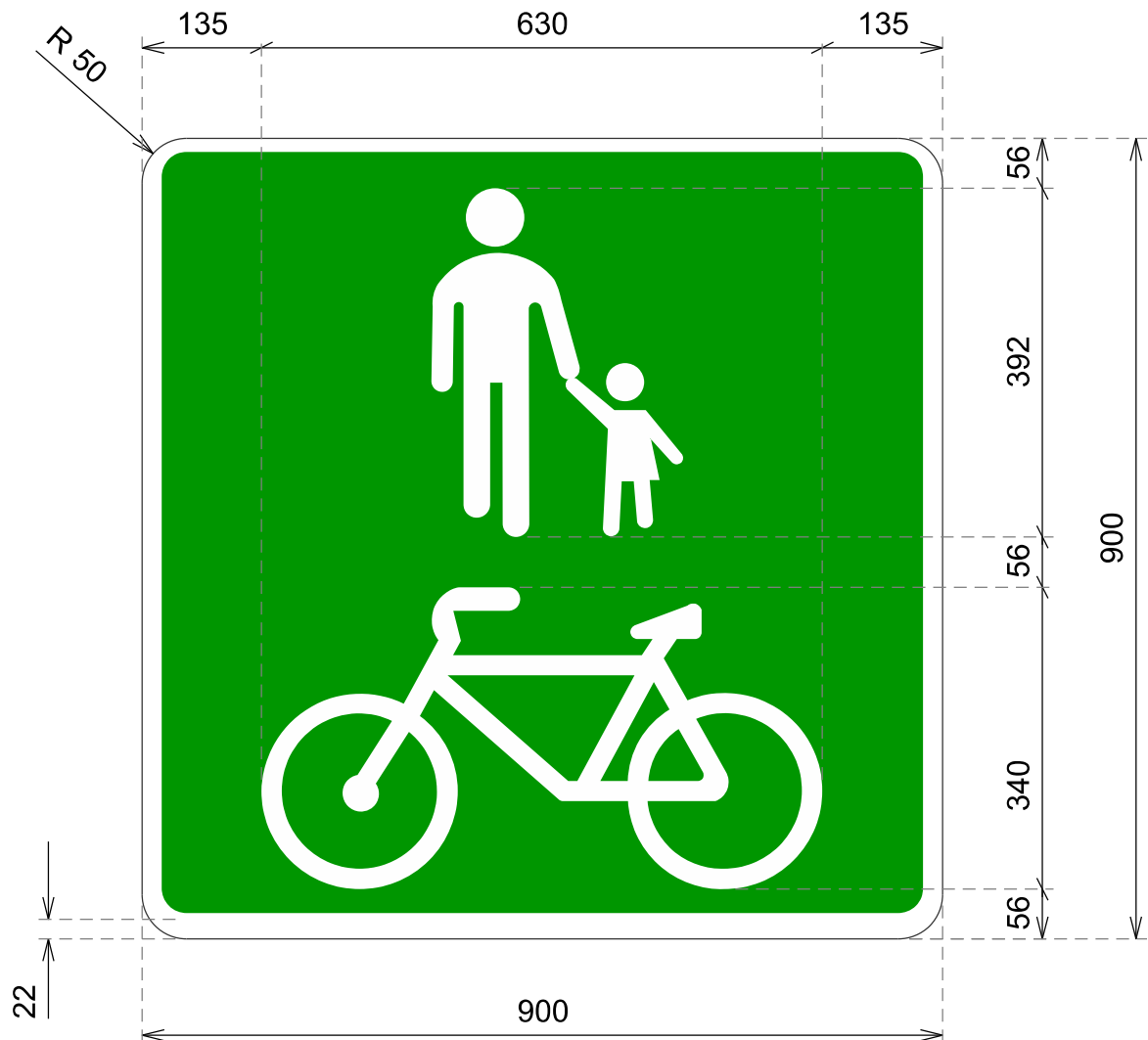

cotas en mm

Senda ciclable

S-33

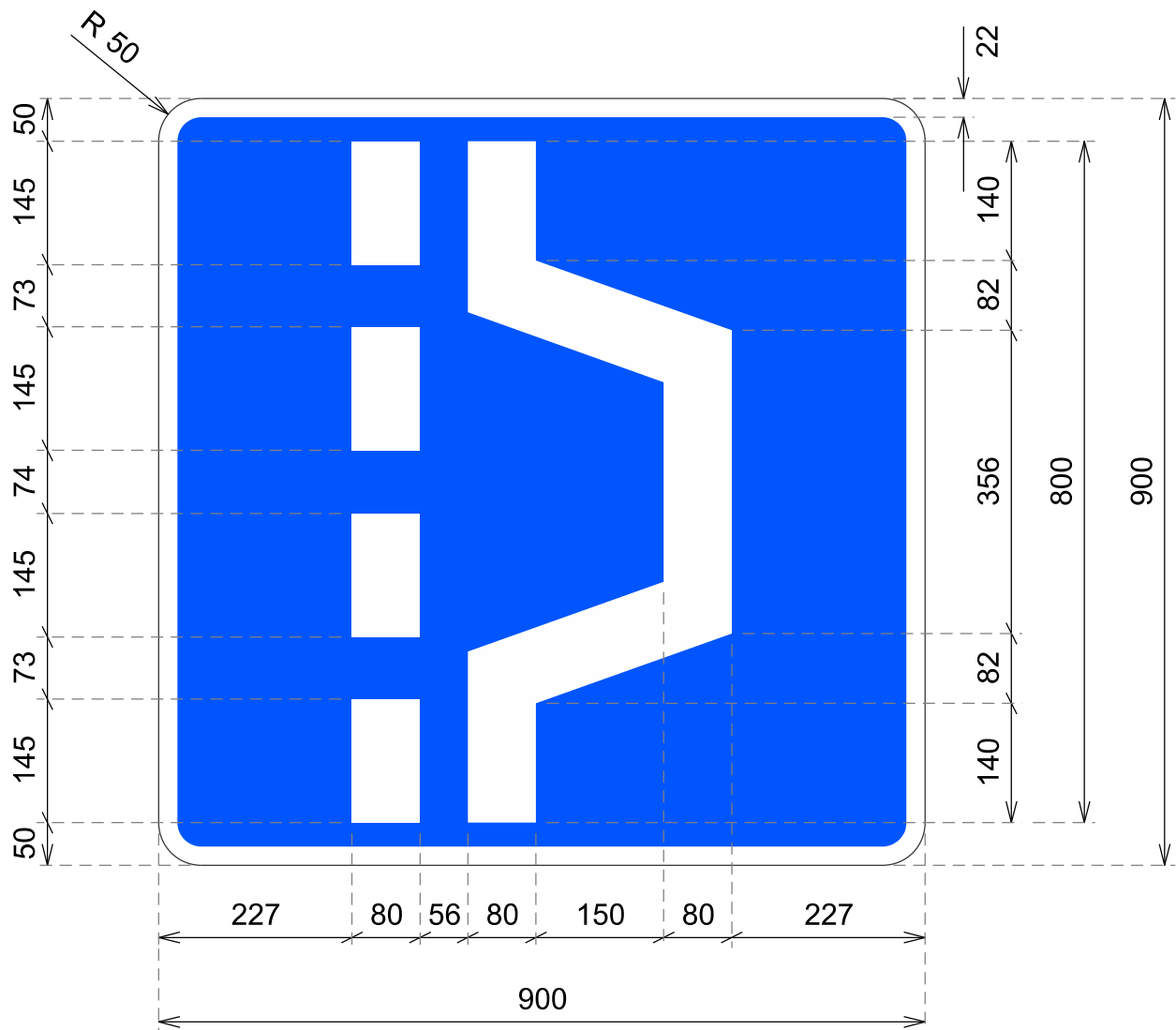

cotas en mm

Apartadero

S-34



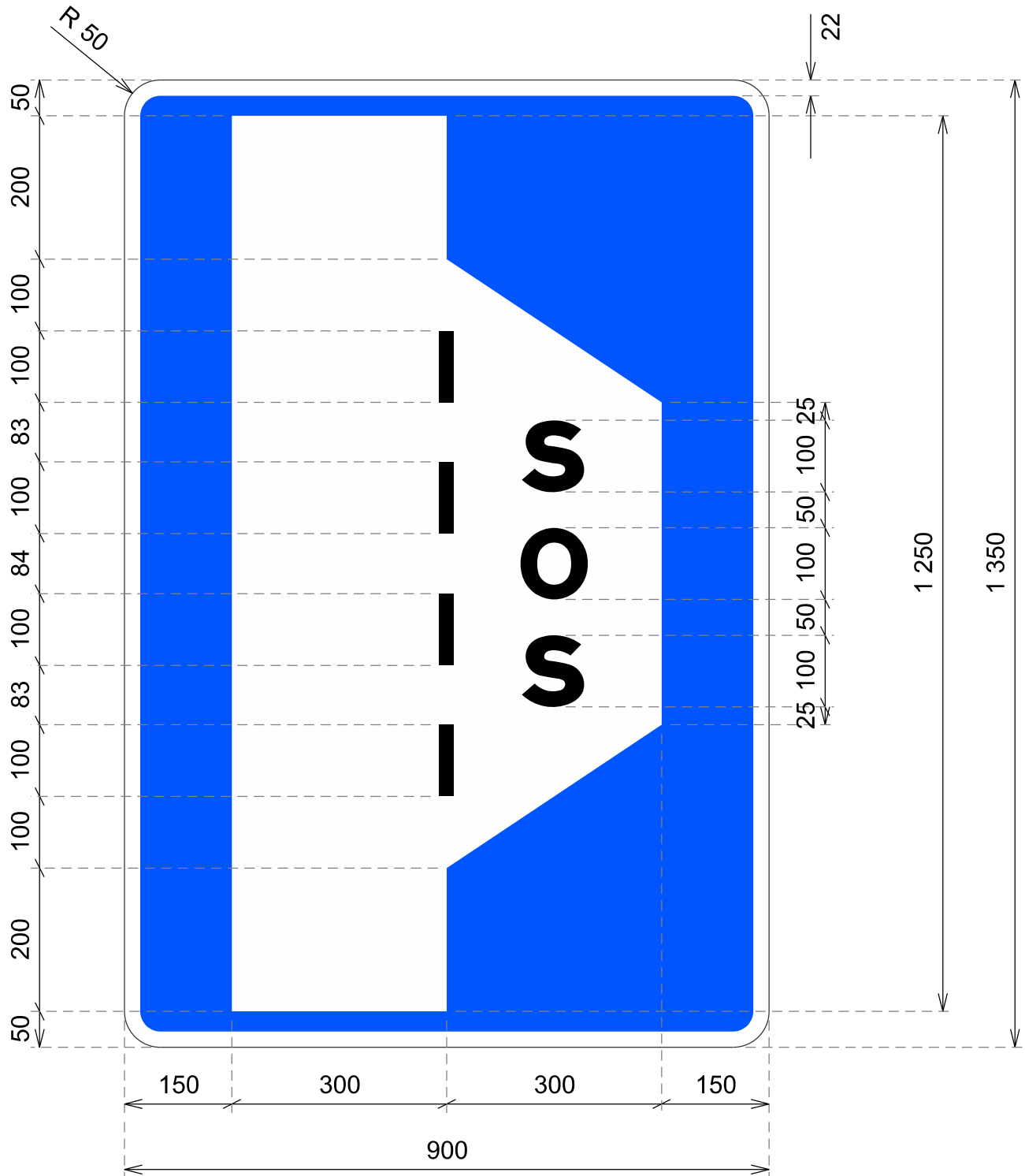

cotas en mm

Apartadero en túneles con teléfono de emergencia

**S-34a**

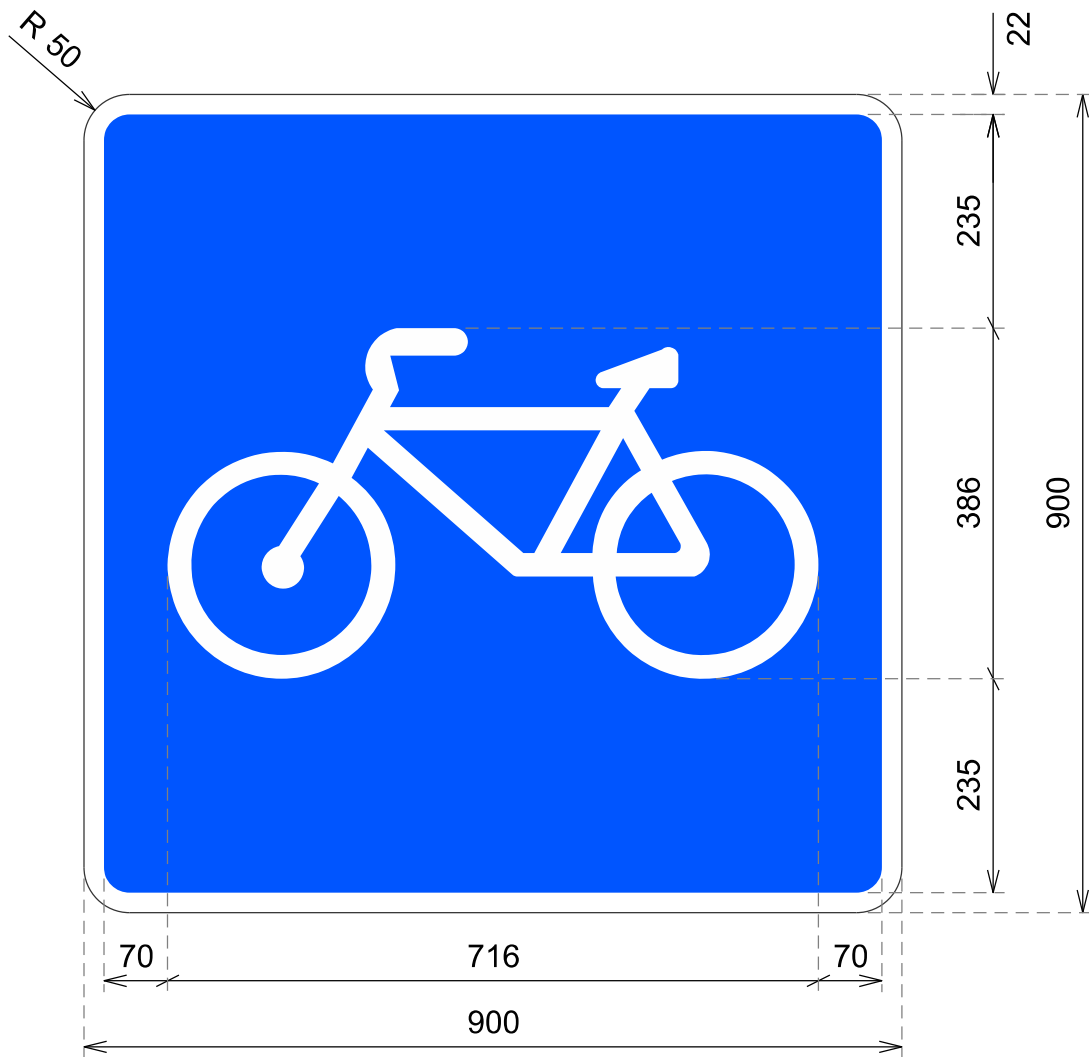

cotas en mm

Vía reservada para ciclos

S-35

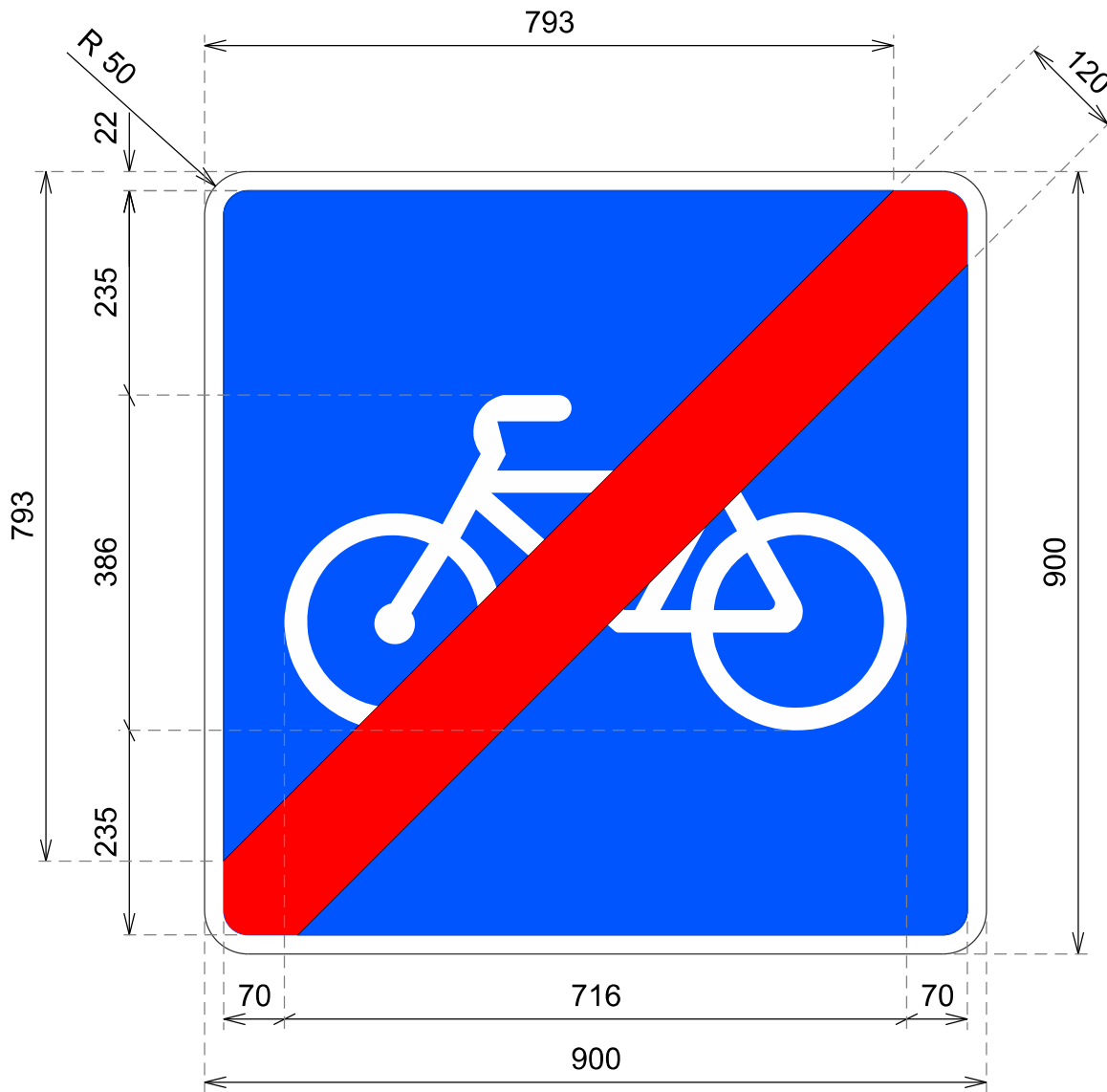

cotas en mm

Fin de vía reservada para ciclos

S-36

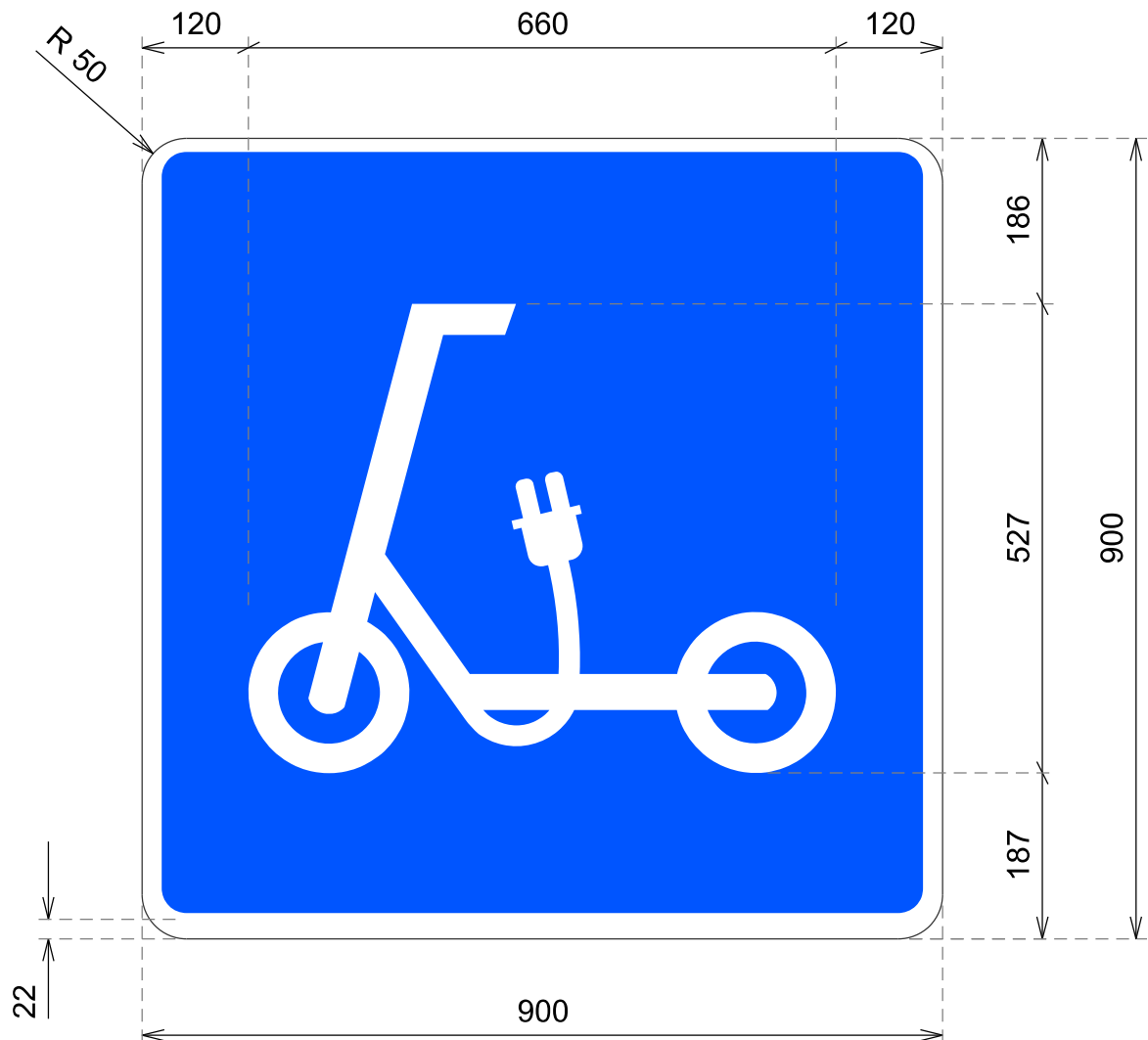

cotas en mm

Vía reservada para vehículos de movilidad personal

**S-37**

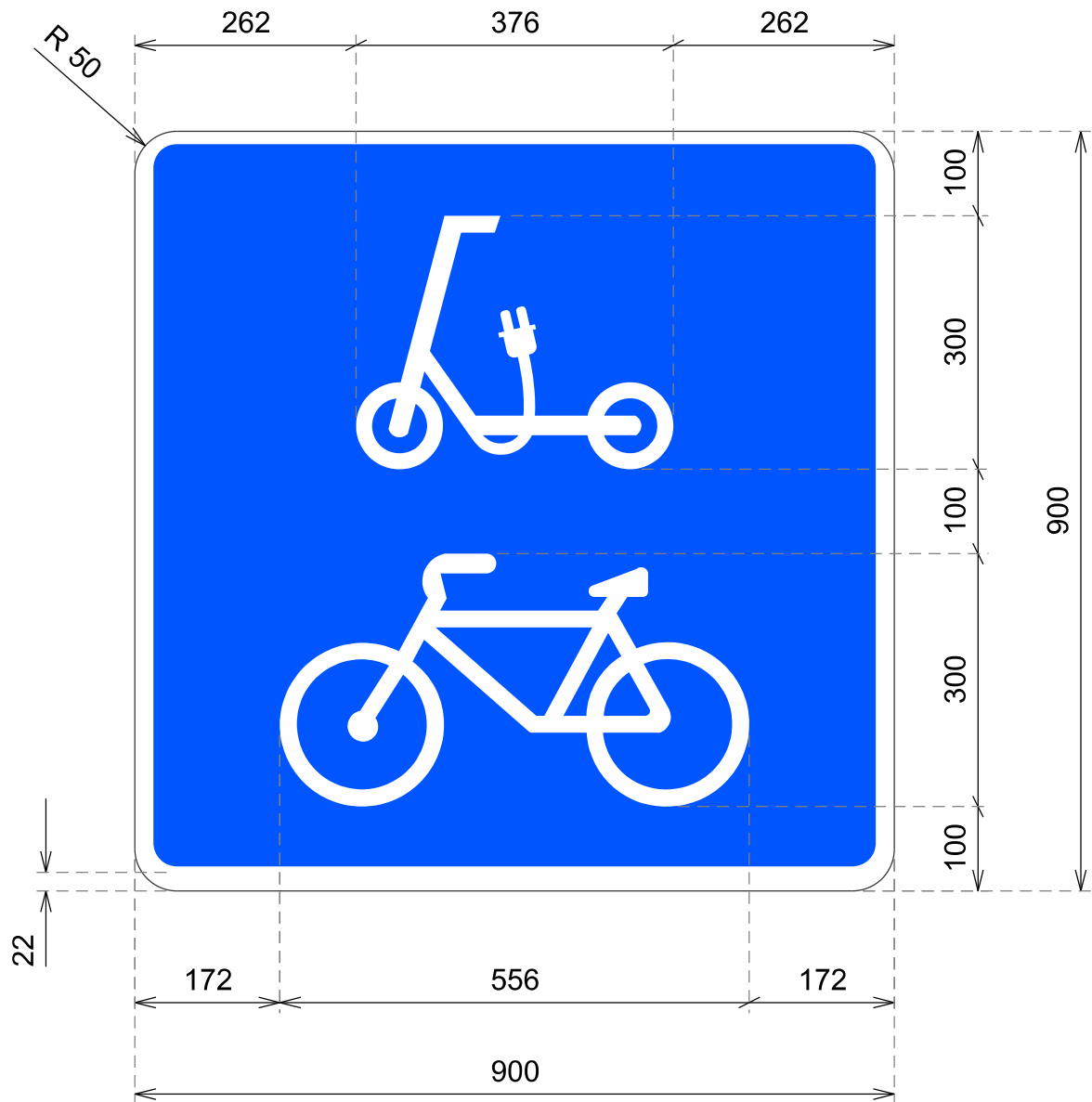

cotas en mm

Vía reservada para ciclos y  
vehículos de movilidad personal

S-38

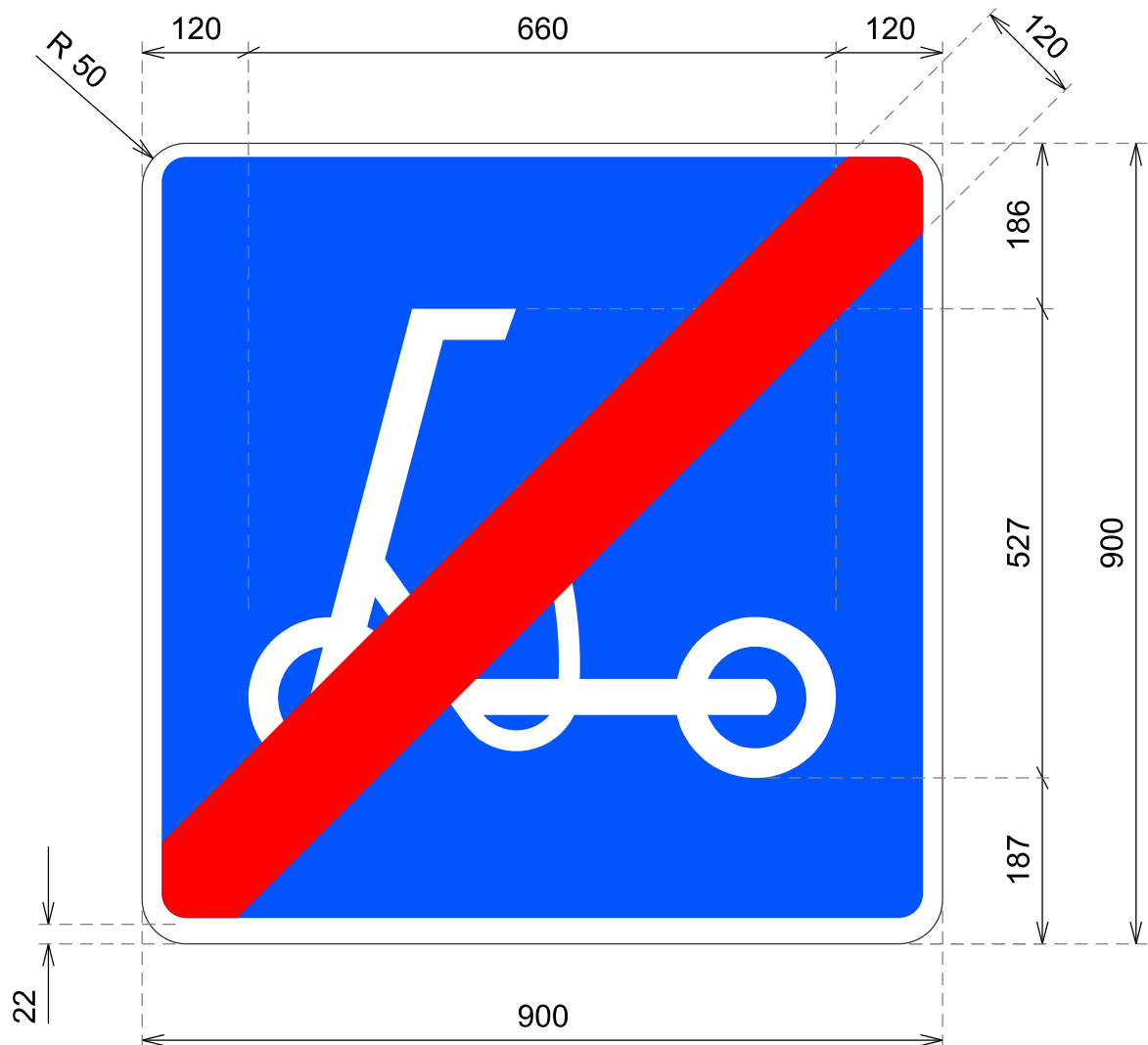

cotas en mm

Fin de vía reservada para vehículos de  
movilidad personal

S-39

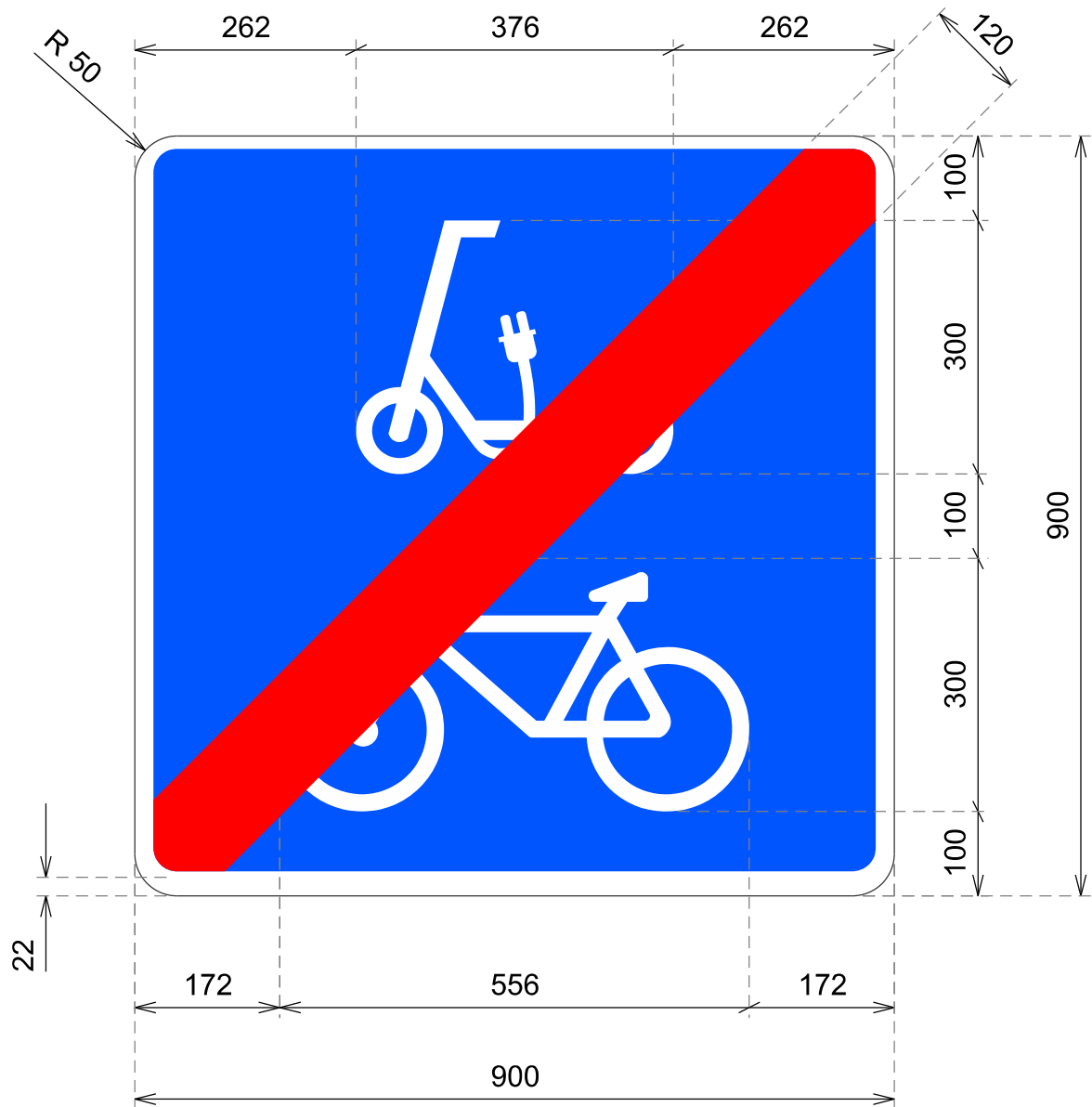

cotas en mm

Fin de vía reservada para ciclos y  
vehículos de movilidad personal

S-40

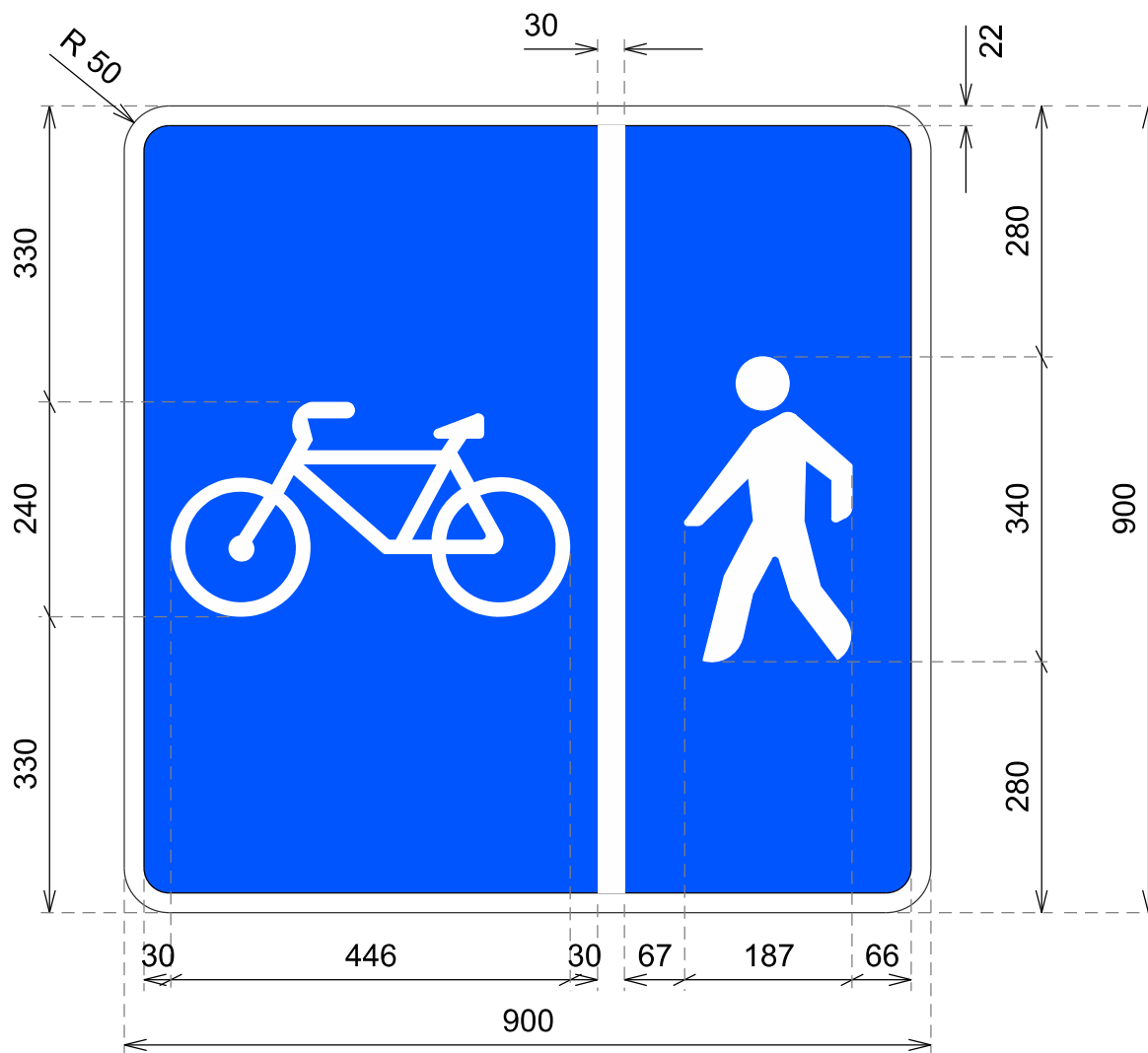

cotas en mm

Vía reservada para ciclos y peatones con espacio de circulación diferenciado entre ellos

S-41



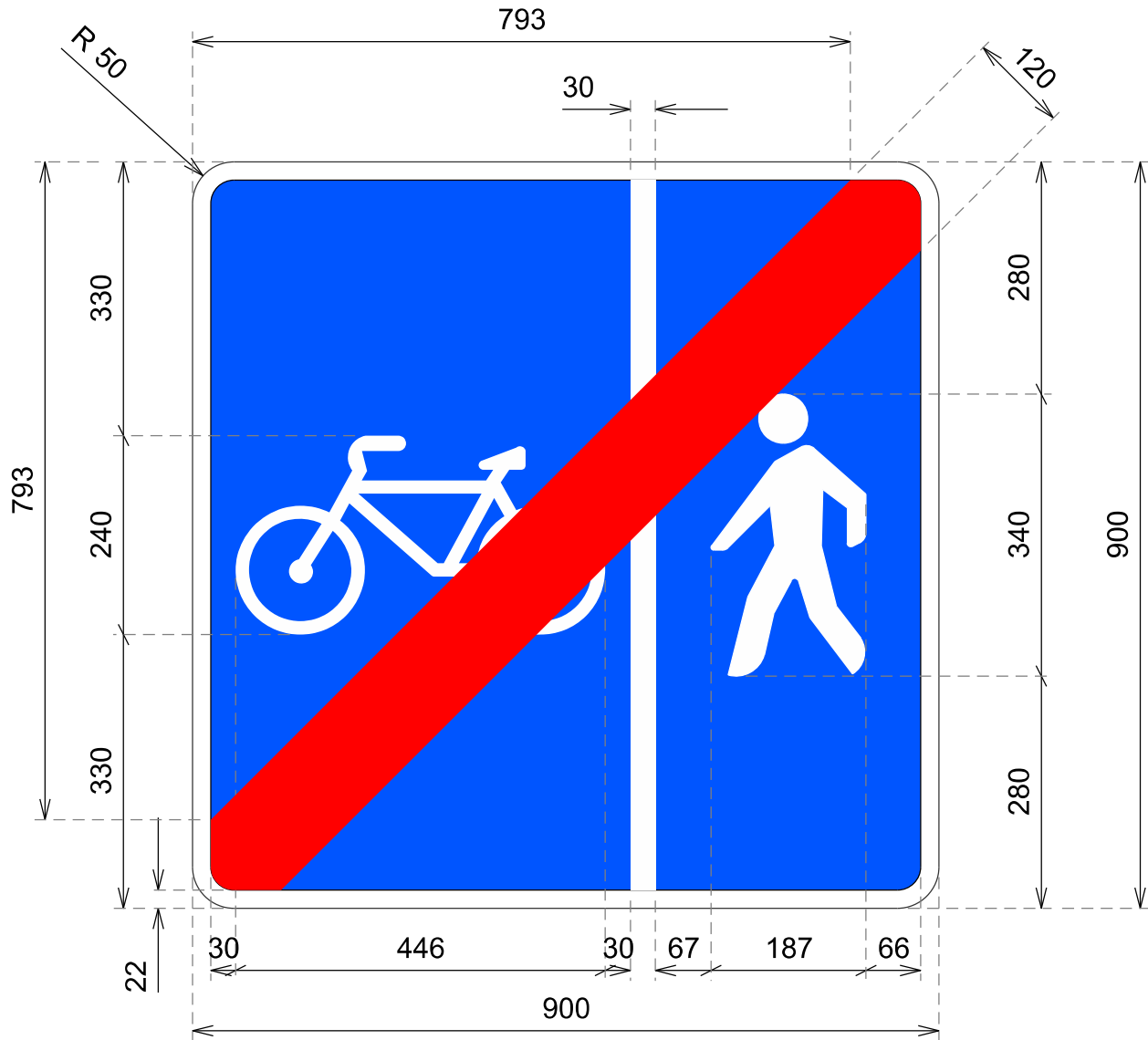

cotas en mm

Fin de vía reservada para ciclos y peatones con espacio de circulación diferenciado entre ellos

S-42



# SEÑALES DE INDICACIÓN

## INDICACIONES GENERALES

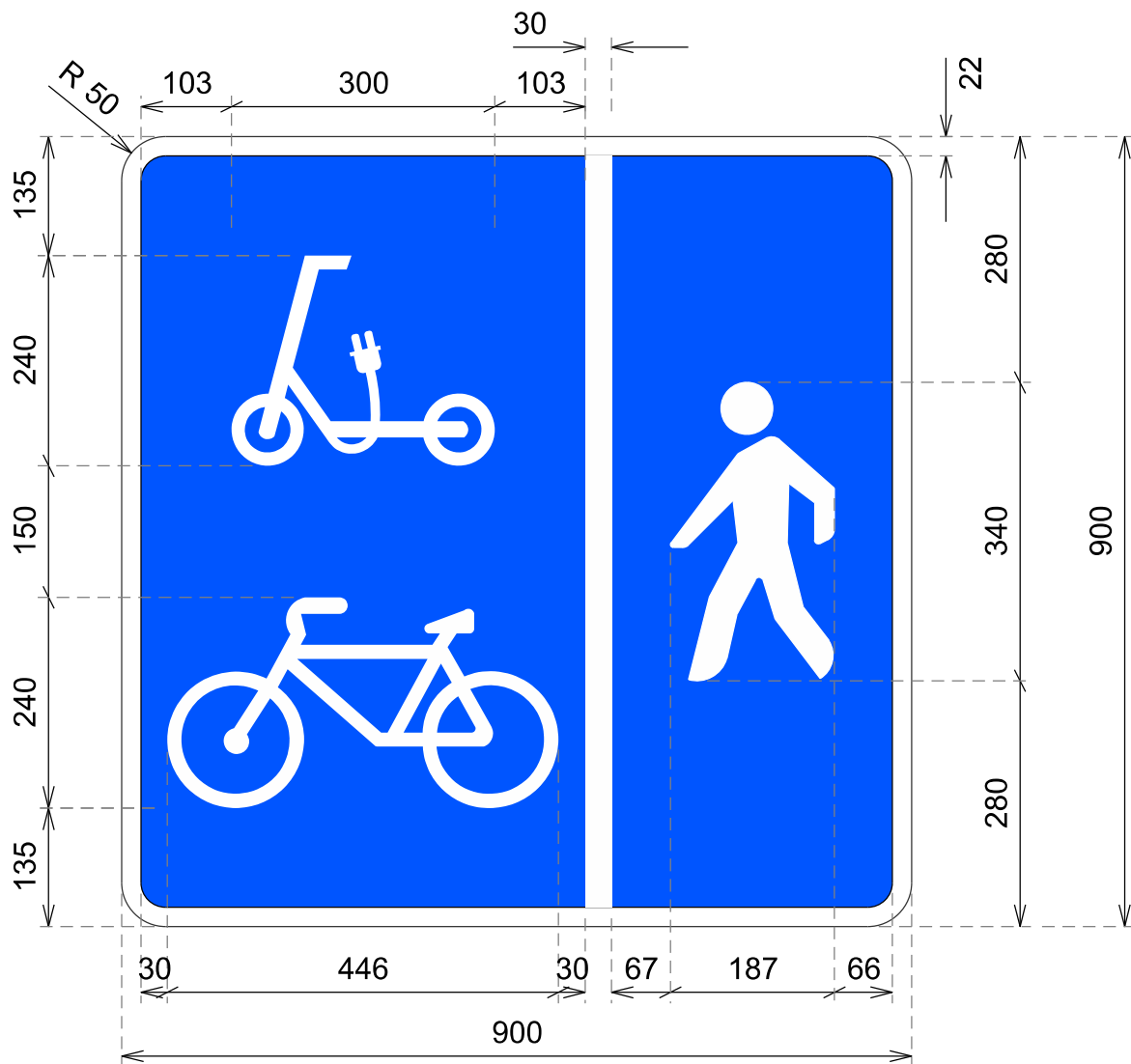

cotas en mm

Vía reservada para ciclos, VMP y peatones, con espacio de circulación diferenciado entre los dos primeros y el tercero

**S-43**

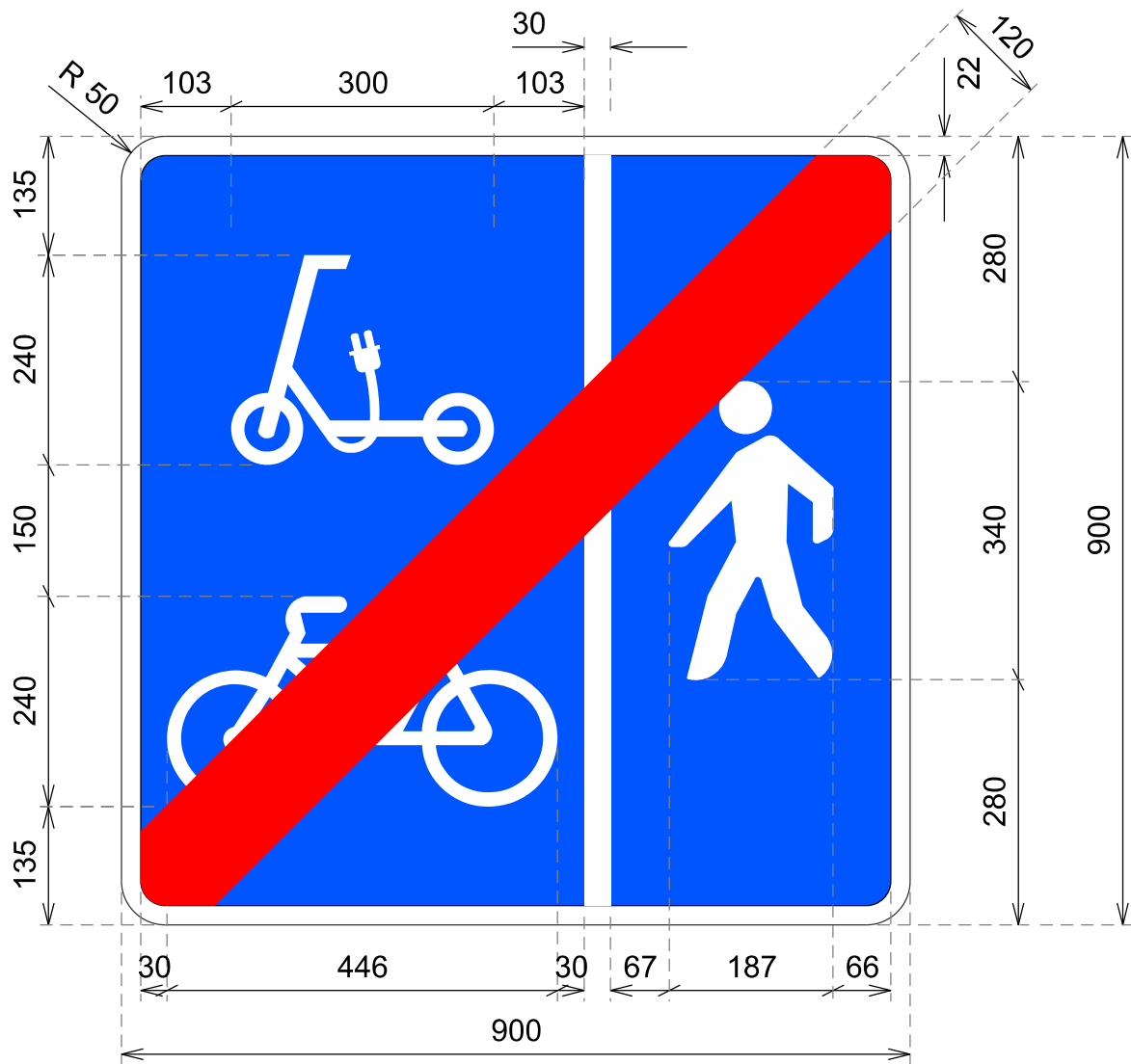

cotas en mm

Fin de vía reservada para ciclos, VMP y peatones, con espacio de circulación diferenciado entre los dos primeros y el tercero

**S-44**

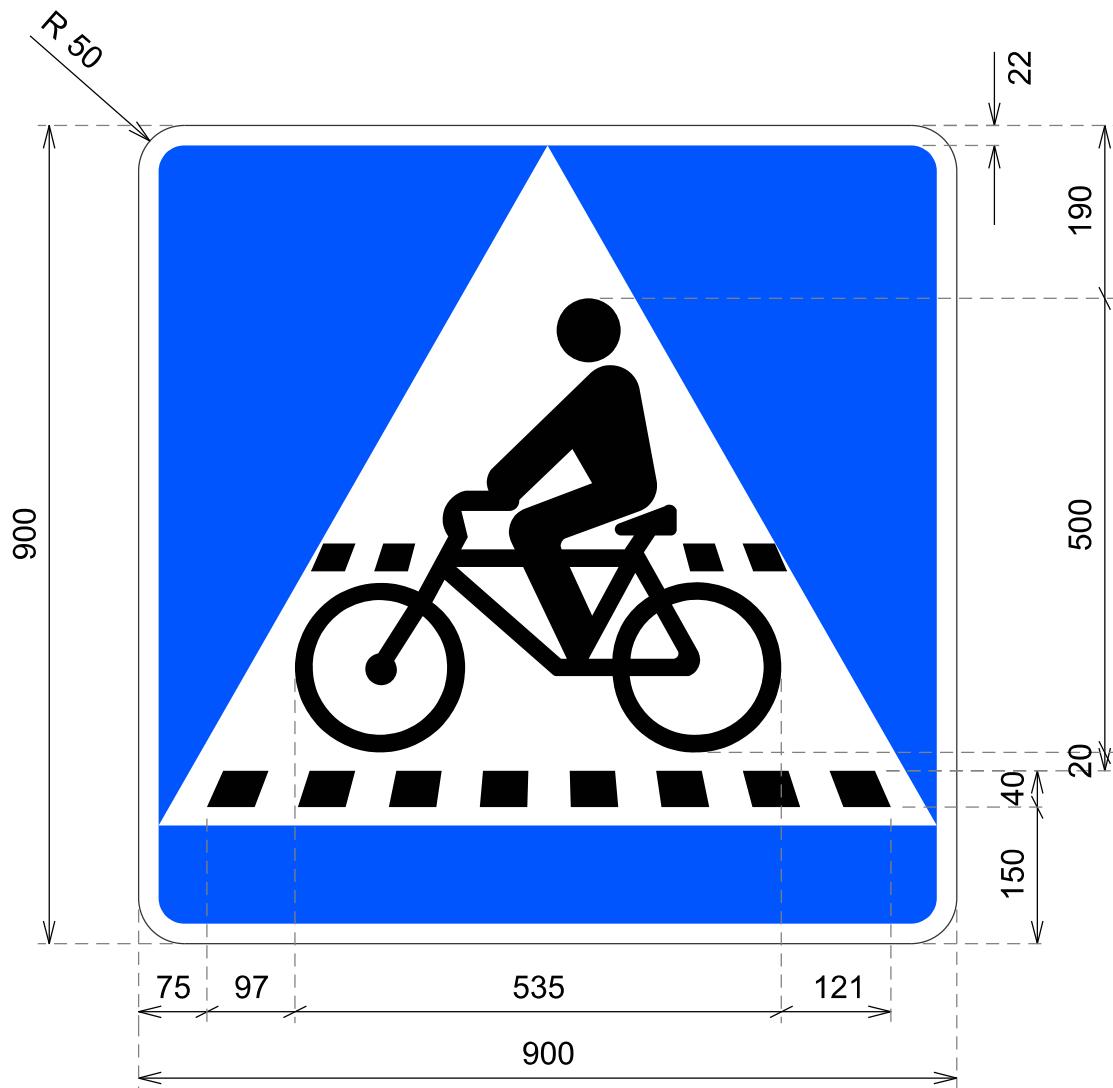

cotas en mm

Situación de un paso para ciclistas

S-45

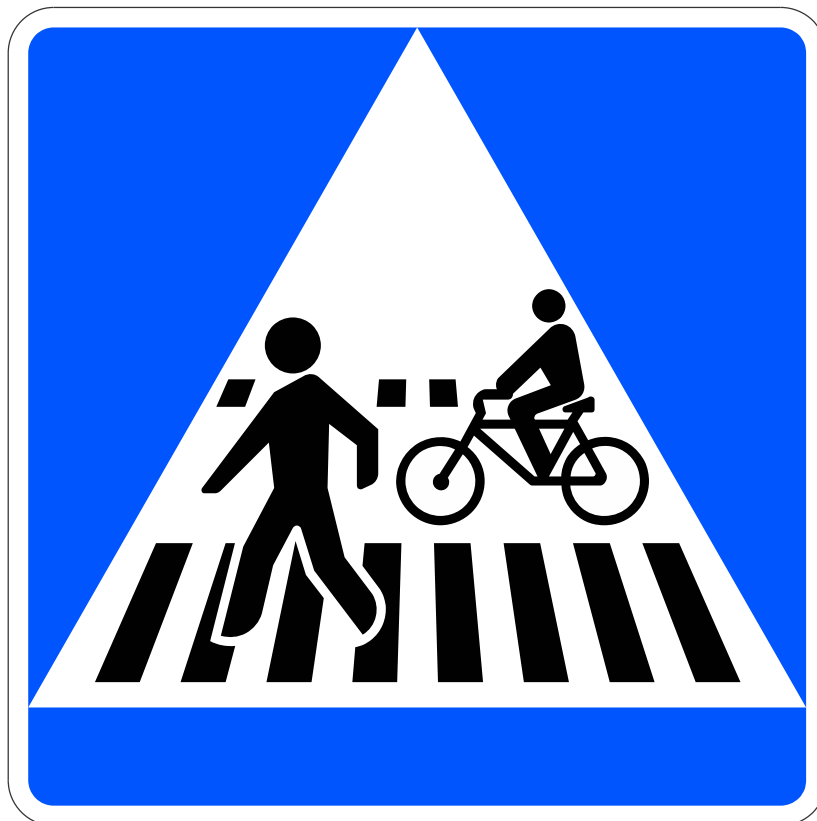

cotas en mm

Situación de un paso para peatones y ciclistas

**S-46**



cotas en mm

Zona de coexistencia de usuarios

S-47

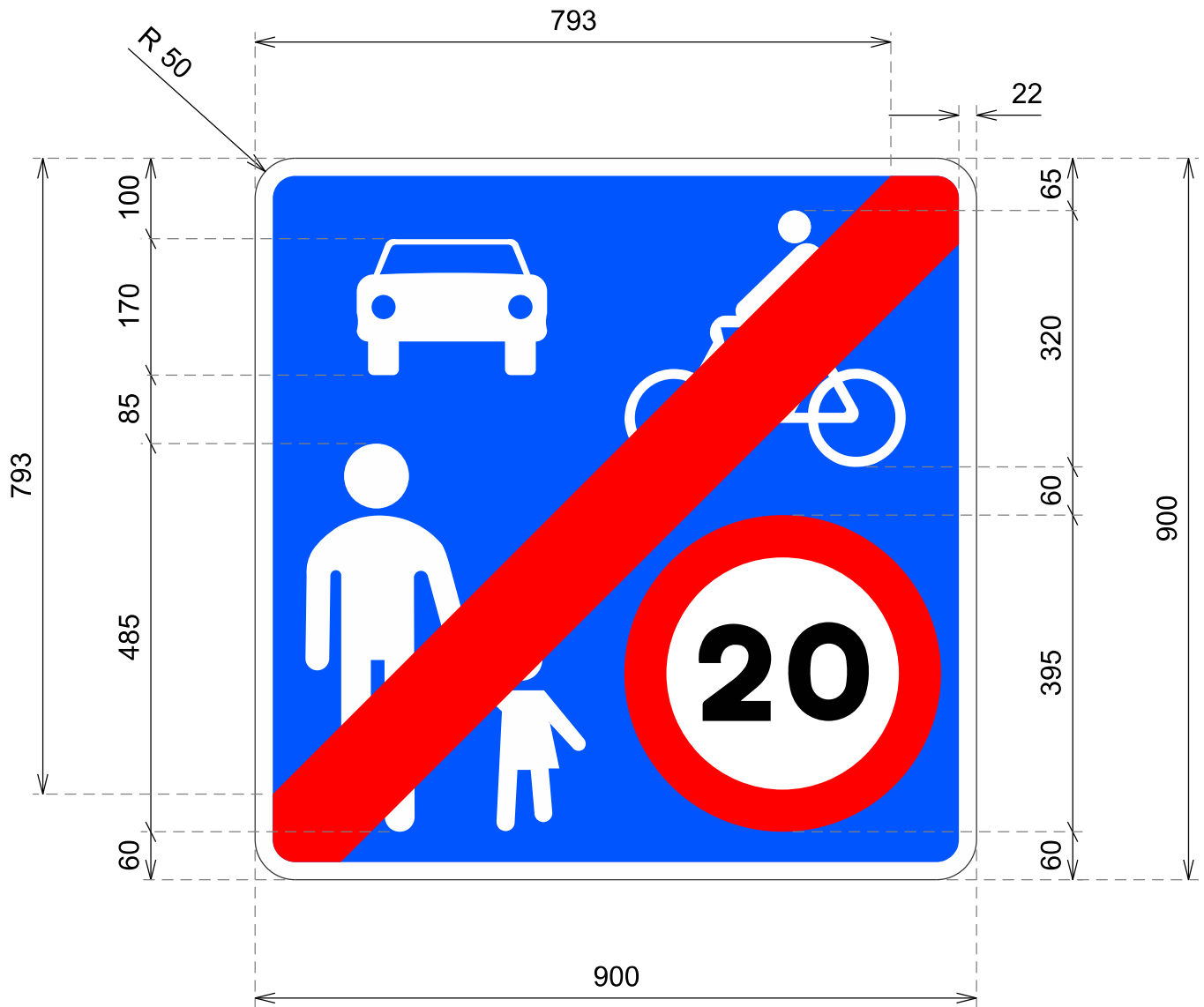

cotas en mm

Fin de zona de coexistencia de usuarios

S-48

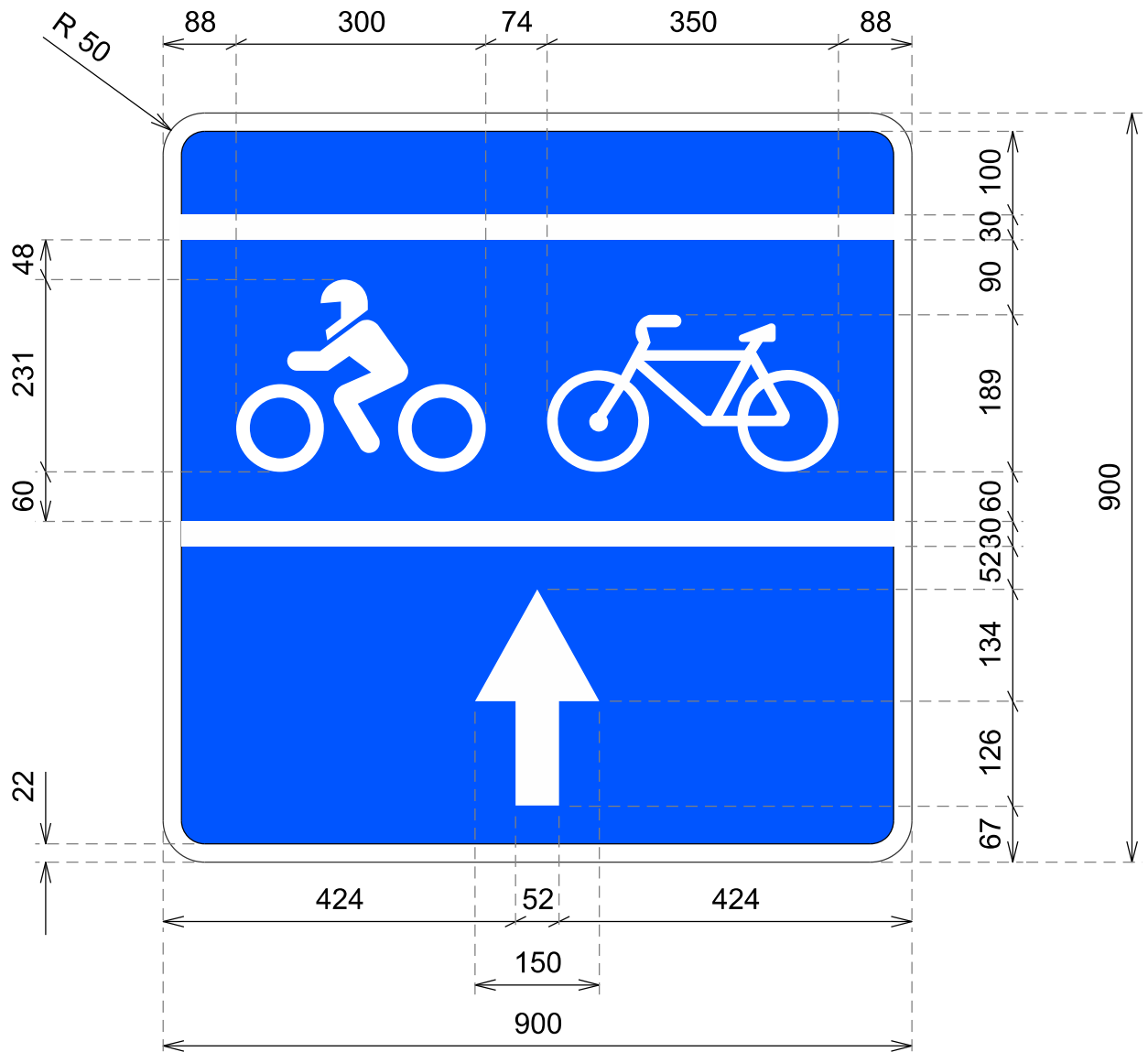

cotas en mm

Avanza moto o bici

S-49